

Introduction to Nuclear Fusion as An Energy Source



Po-Yu Chang

Institute of Space and Plasma Sciences, National Cheng Kung University

Lecture 10

2026 spring semester

Tuesday 9:00-12:00

Materials:

<https://capst.ncku.edu.tw/PGS/index.php/teaching/>

Online courses:

<https://reurl.cc/GaLmxA> (Google meet)



1. [5 points in total] Shown in the following figure (a) is the comparison between cross sections of $^{235}\text{U} + n$ fission and D+T fusion. Please explain why nuclear fission is much easier to achieve than nuclear fusion.

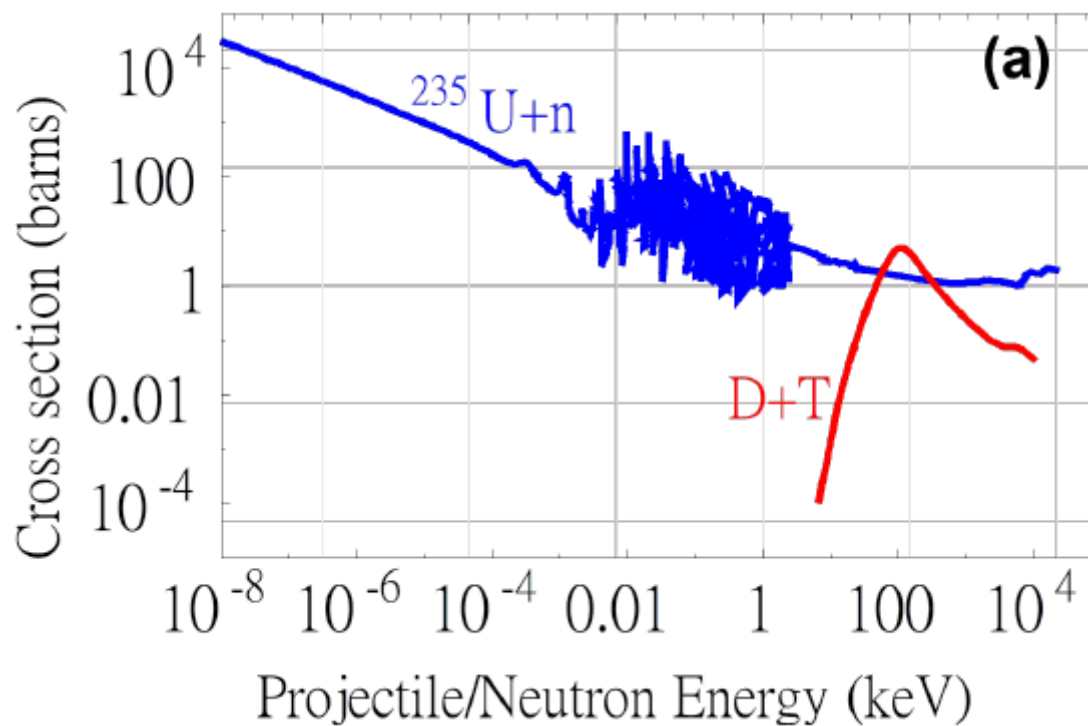

2. [10 points in total] Shown in the above figure (b) is the comparison between cross sections of coulomb scattering, D-T fusion, and D-D fusion. Please explain why “beam-target” fusion is not viable for energy generation.

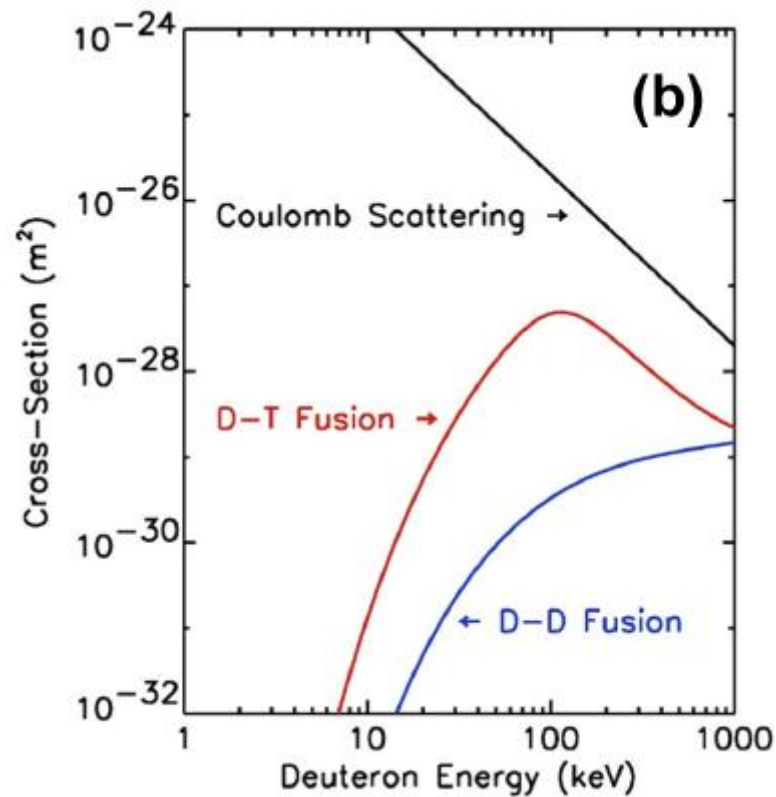

Coulomb scattering is more likely to happen than nuclear fusion

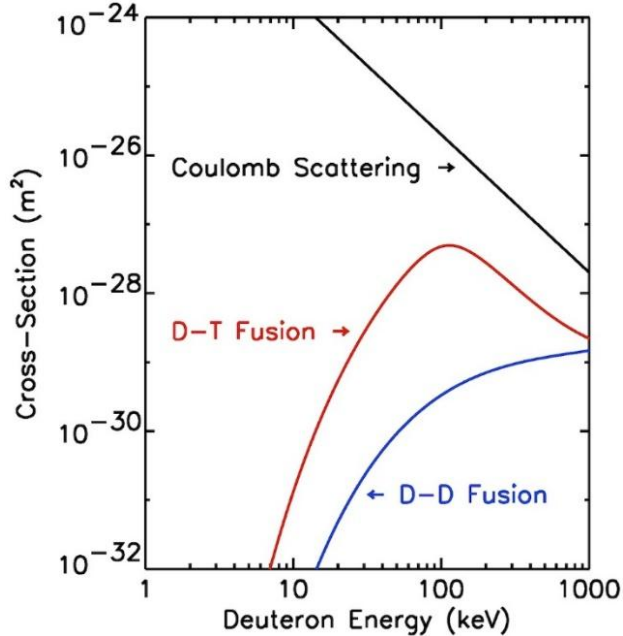
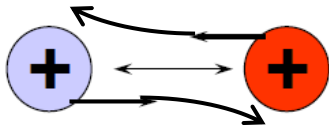

$E_{\text{incoming}} = 100 \text{ keV}$

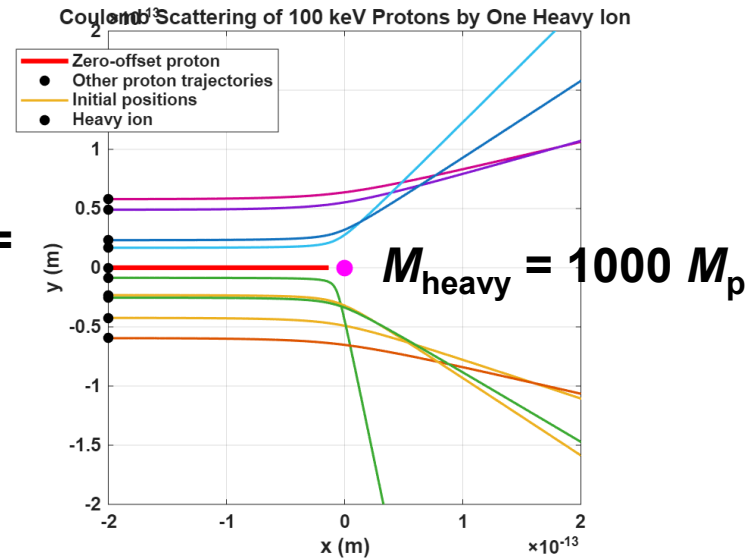

- Beam particles lose their energy before making a fusion reaction, i.e., they only thermalize the fuel. Therefore, beam fusion does NOT work!

Who wins the game? Who wins the money?



- One game:

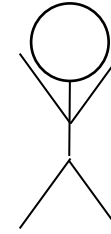
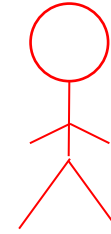

	Alice	Bob
Winning probability	0.00001%	99.99999%
Winning money	\$100	\$0
Who win after one game?	X	O
Who win the money after one game?	X	X
Who wins most the games over one night?	X	O
Who wins the money after one night?	O	X

- One night:

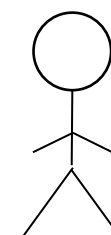
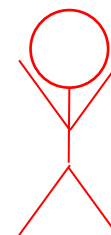

Hot plasma needs to be confined so that particles have chance to collide with each other

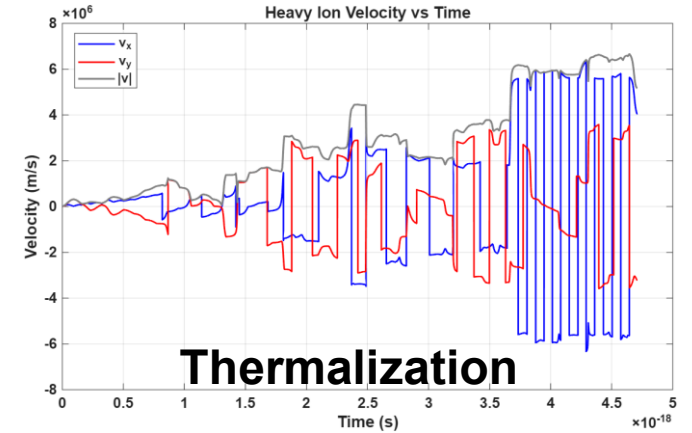
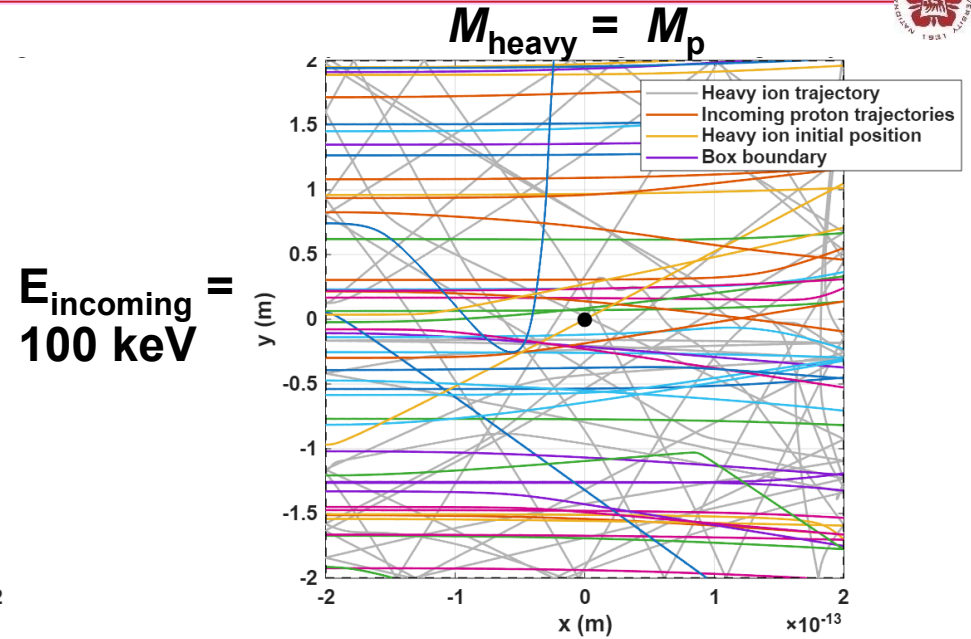
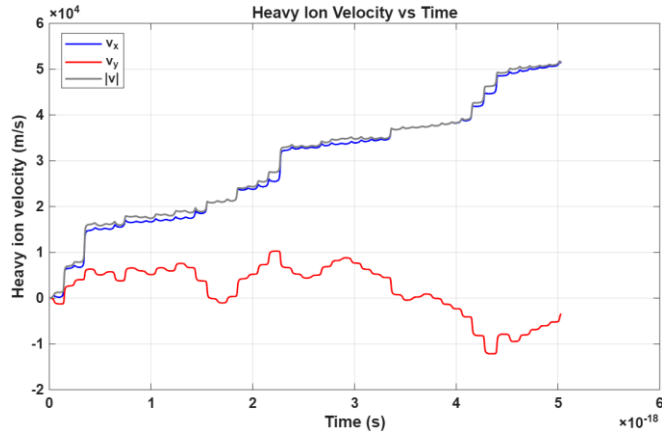
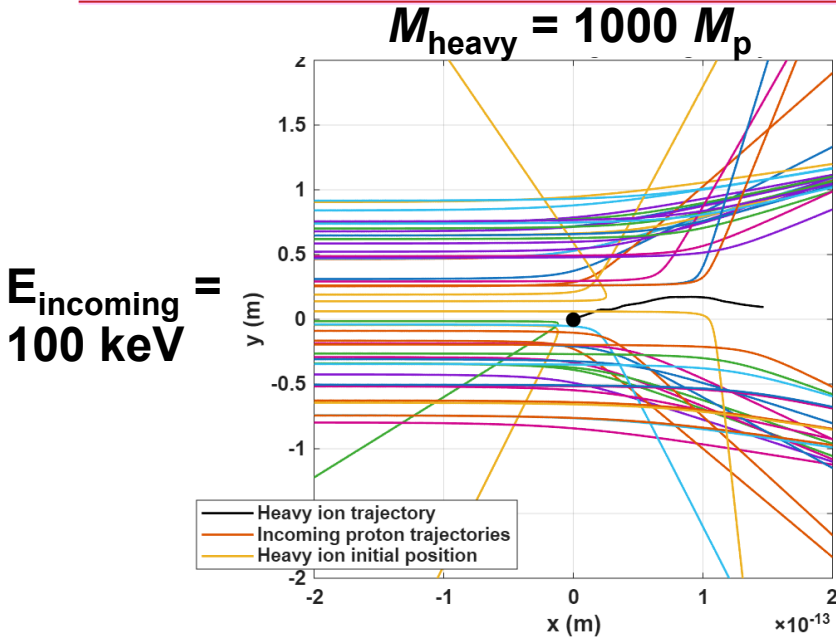

• Beam particles just thermalize the fuel. Beam-target fusion does NOT work!

Fusion doesn't come easy, a "hot plasma" at 100M °C is needed

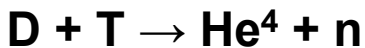
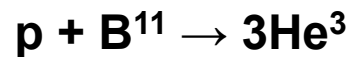
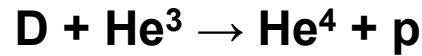
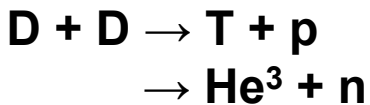
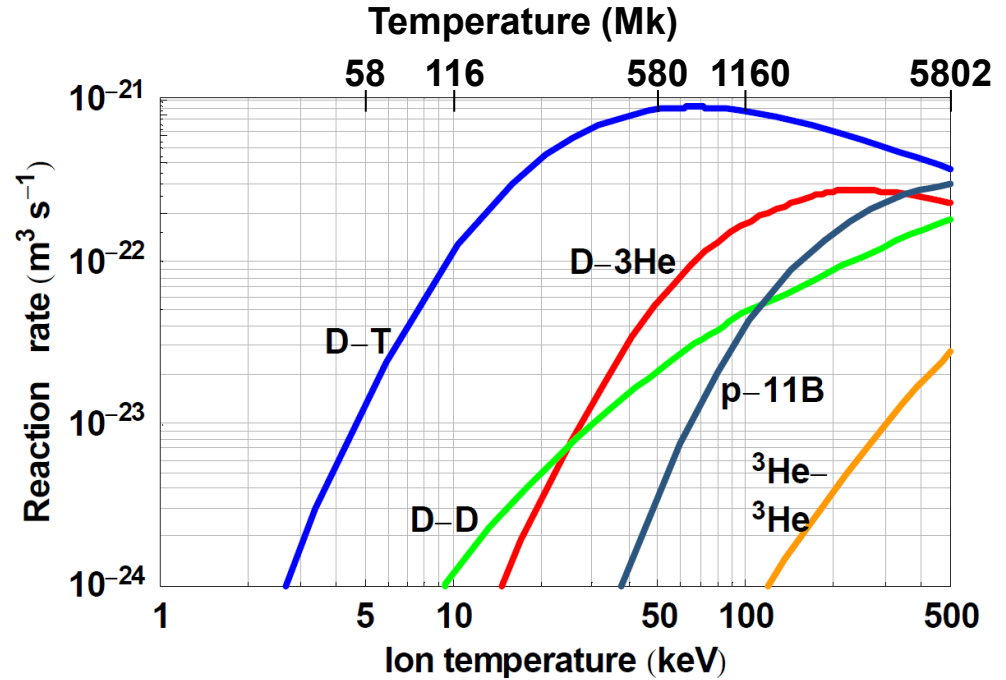
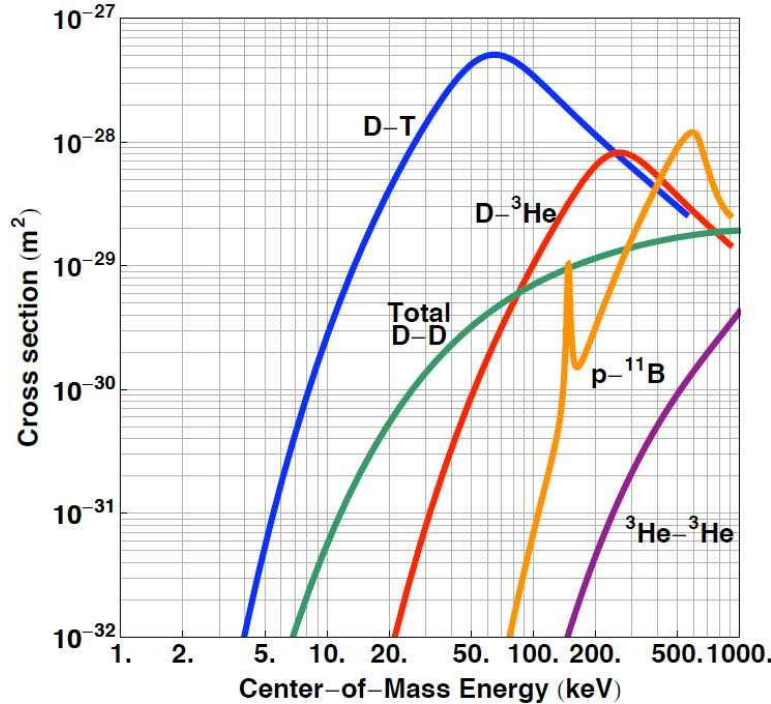

• Reaction rate:

$$\langle \sigma v \rangle = \int \sigma(v) v f(v) dv$$

Cross section

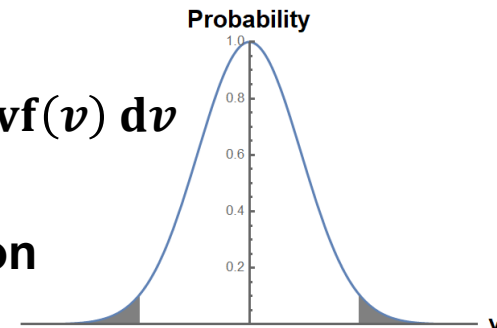

<https://i.stack.imgur.com/wXQD5.jpg>

Santarius, J. F., "Fusion Space Propulsion – A Shorter Time Frame Than You Think", JANNAF, Monterey, 5-8 December 2005.

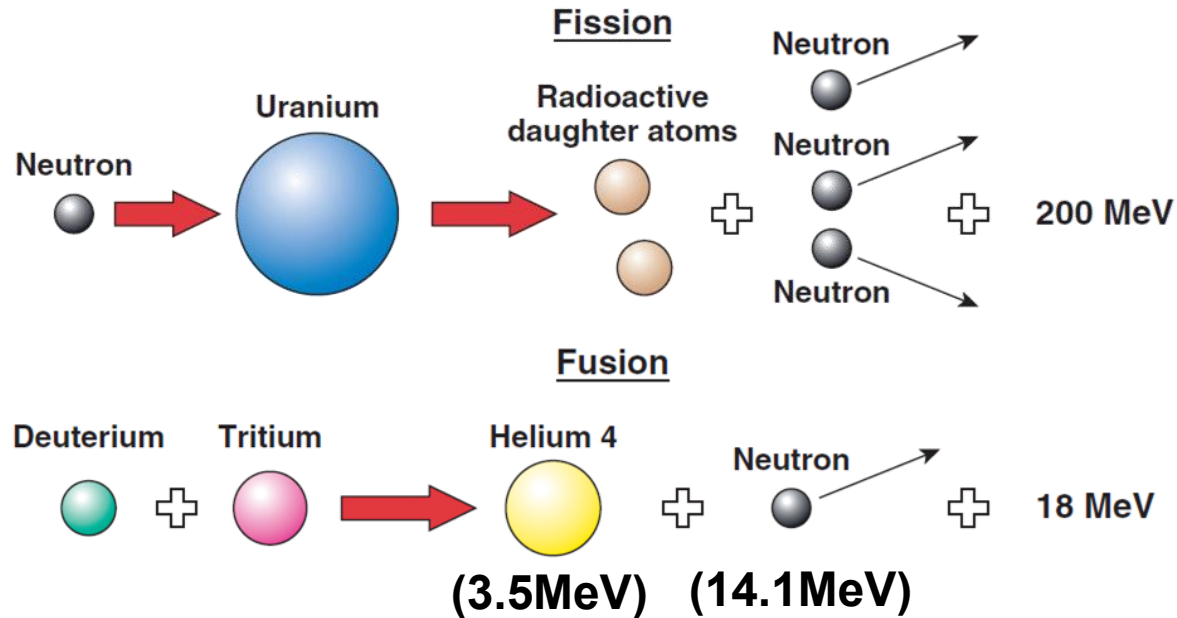

- **Fission of ^{235}U :**
$$\frac{Q}{A} = \frac{200 \text{ MeV}}{(235 + 1)\text{amu}} = 0.85 \text{ MeV/amu}$$

- **Fusion of D+T:**
$$\frac{Q}{A} = \frac{17.6 \text{ MeV}}{(2 + 3)\text{amu}} = 3.5 \text{ MeV/amu}$$

4. [5 points in total] To have a self-sustain system such that the plasma can be heated by itself and remains hot, the heating from the alpha particles generated in the D-T fusion reactions ($D + T \rightarrow {}^4\text{He} + n$) needs to be higher than the energy losses, which are mostly by Bremsstrahlung radiations at high temperature. As a result, an ignition condition, called the Lawson criterion, where $P\tau > 10 \text{ atm} - \text{s}$, needs to be achieved. Please explain the physical meaning, NOT the math, of the criterion.

- **Steady state 0-D power balance:**

$$S_{\alpha} + S_h = S_B + S_k$$

S_{α} : α particle heating

S_h : external heating

S_B : Bremsstrahlung radiation

S_k : heat conduction lost

Ignition condition: $P\tau > 10 \text{ atm-s} = 10 \text{ Gbar} - \text{ns}$

- **P**: pressure, or called energy density
- **τ** is confinement time

5. [10 points in total] The magnetic field of Formosa Integrated Research Spherical Tokamak (FIRST) is $B_T = 0.1$ T at $R = 45$ cm. The small radius of FIRST is $a = 32$ cm. Hydrogen gas will be used in FIRST. To simplify the problem, assume the cross section of FIRST on the poloidal plane is a perfect circle with the small radius $a = 32$ cm. When the temperature of protons achieves 100 eV, is the field of 0.1 T is enough to confine 100-eV protons?

6. [10 points in total] Shown in the following is the loss function from line, recombination-induced, and bremsstrahlung radiation for different atoms at different temperatures. Please explain (a) what a “radiation barrier” at 100 eV is [7 points], and (b) why a temperature of 100 eV was picked as the milestone for the Formosa Integrated Research Spherical Tokamak (FIRST)? [3 points]

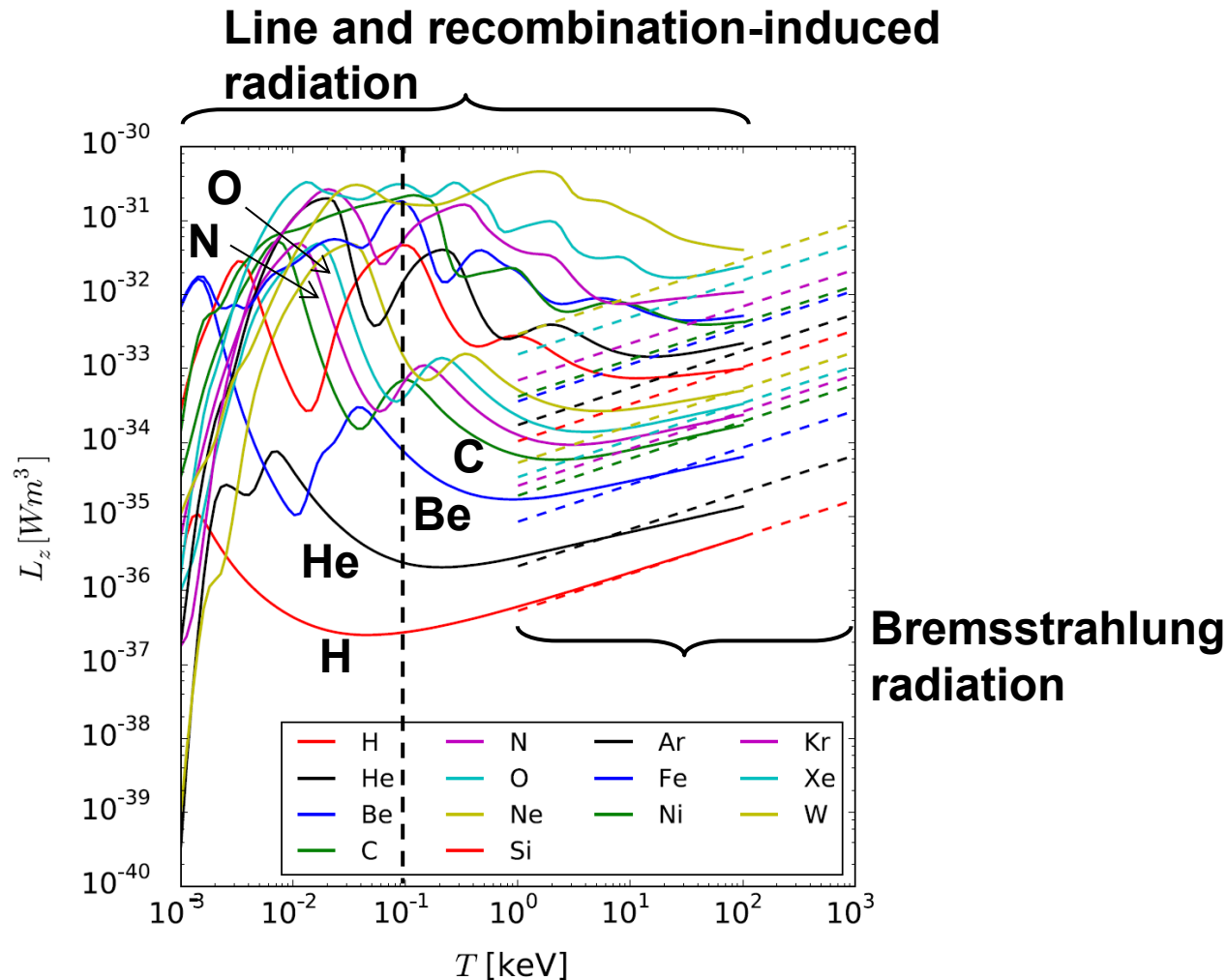



7. [5 points in total] Shown in the following figure (a) are the cross sections of different fusion reactions for different center-of-mass energy (in keV). On the other hand, the following figure (b) are the reaction rates of different fusion reactions at different temperature (in keV). Please explain what's the difference between “cross sections” and “reaction rates”?

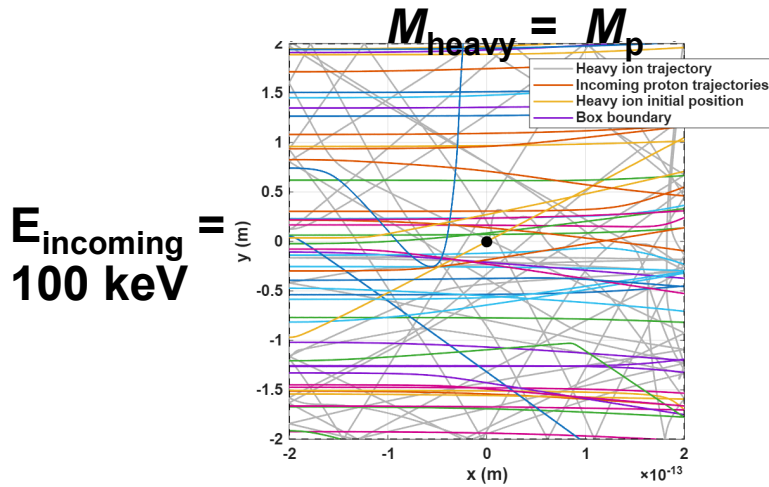
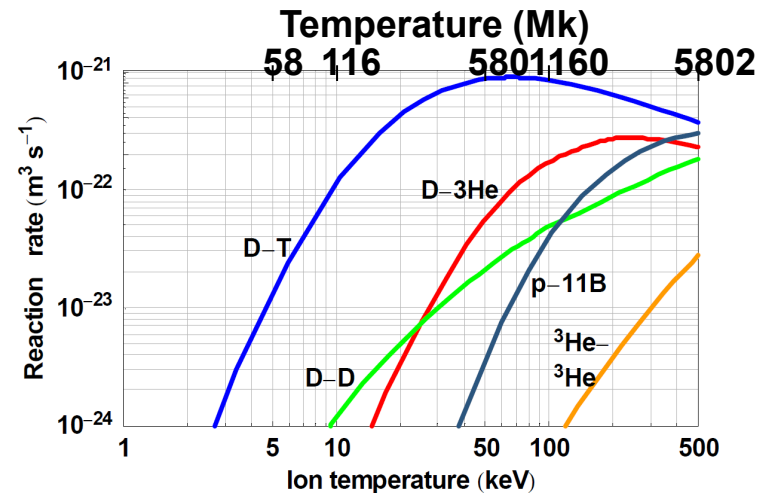
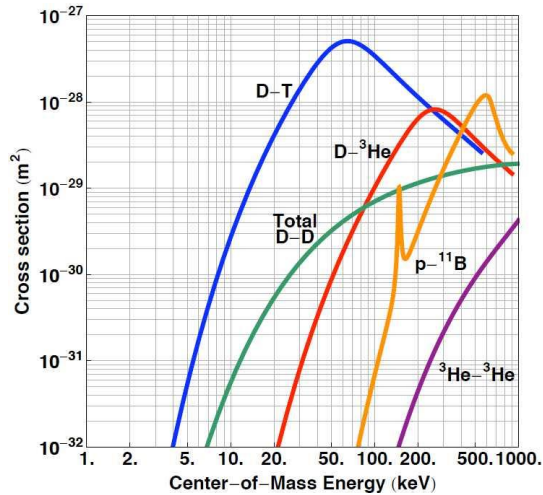

• Reaction rate:

$$\langle \sigma v \rangle = \int \sigma(v) v f(v) dv$$

↖ Cross section

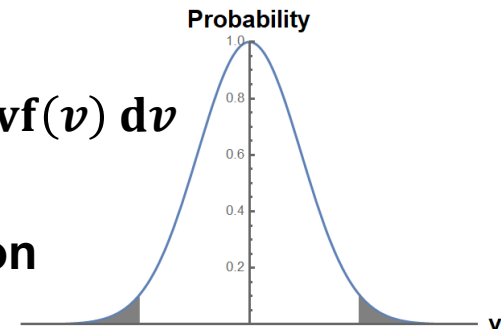

<https://i.stack.imgur.com/wXQD5.jpg>

Santarius, J. F., “Fusion Space Propulsion – A Shorter Time Frame Than You Think”, JANNAF, Monterey, 5-8 December 2005.

8. [10 points in total] In homework 1, we plotted trajectories of electrons and protons with only toroidal magnetic field and a negative electric field to mimic consequence of the charge separation. Following are the 3D trajectories of electrons and protons in figure (a), and the poloidal-plane projection of trajectories in figure (b). Red curves are for electrons while blue curves are for protons in both figures. Please explain what happen and why particles can not be confined with only toroidal fields.

(a) Trajectories of electrons and Protons with only Toroidal fields

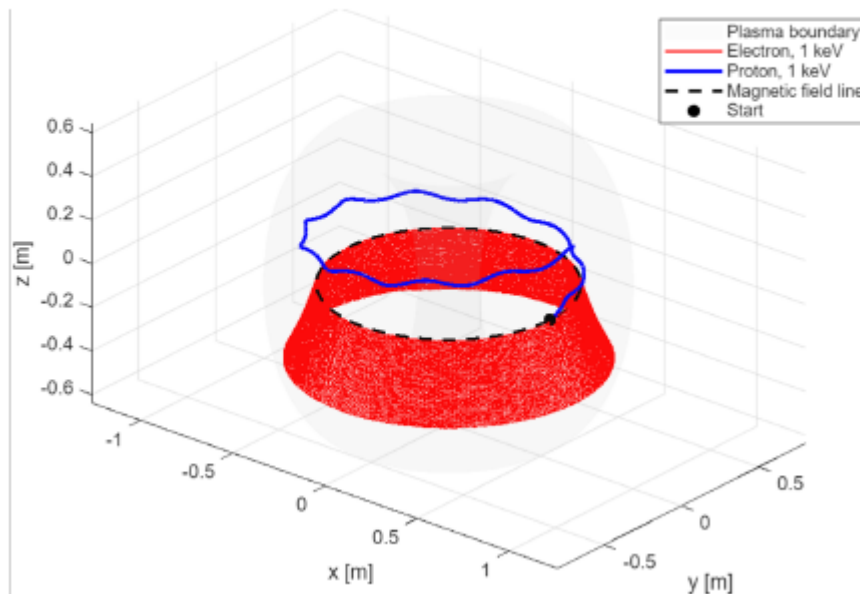

(b) Poloidal-plane projection of trajectories

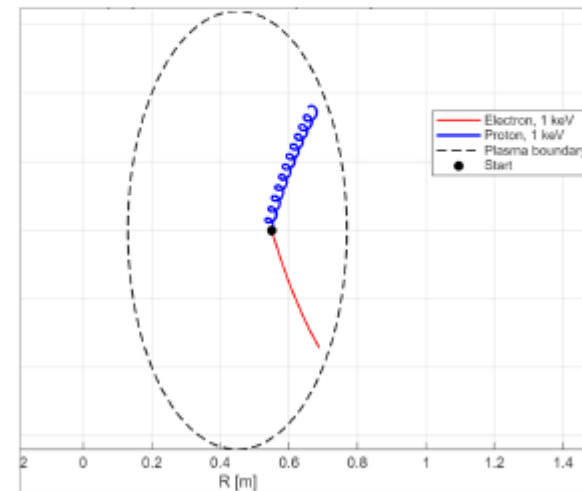

4. [10 points in total] A spherical tokamak with a major radius $R = 45$ cm, a minor radius $a = 32$ cm, and an elongation of $\kappa = 2$. The toroidal field $B_T = 0.1$ T at 45 cm. The plasma current $I_p = 0$. An **electron** with an energy of 1 keV. Initial position at $R = 55$ cm. Please compare the result with condition 3.



3D Electron and Proton Trajectories in Tokamak Toroidal Field

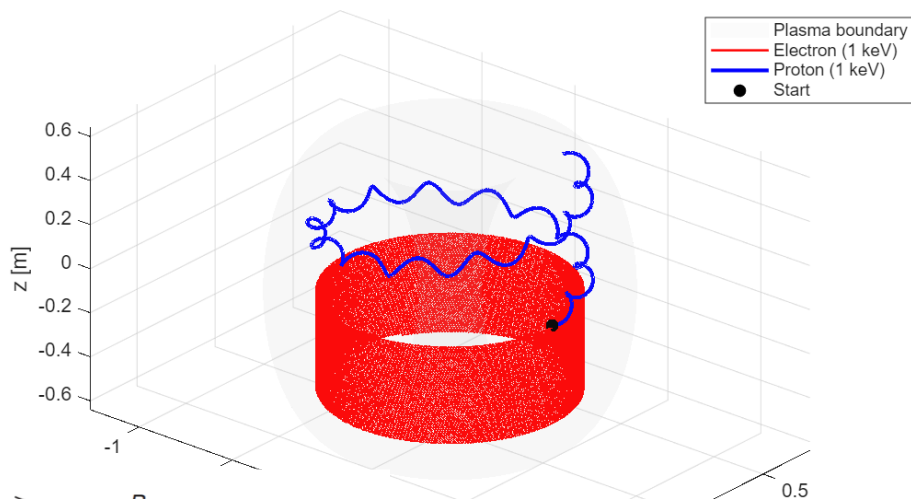

3D Electron and Proton Trajectories in Tokamak Toroidal Field

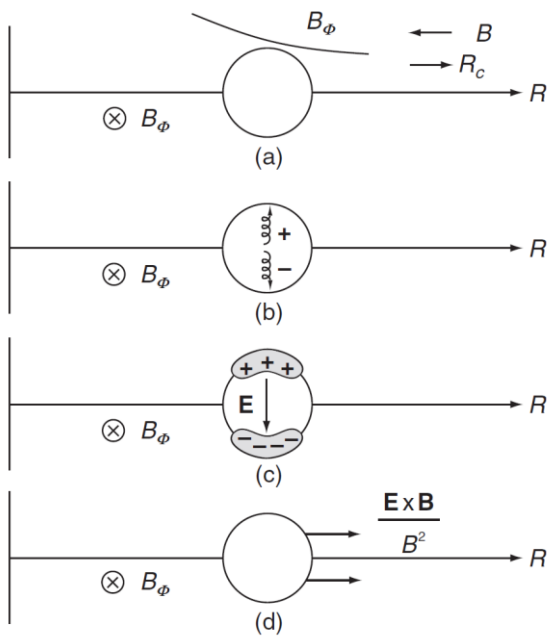
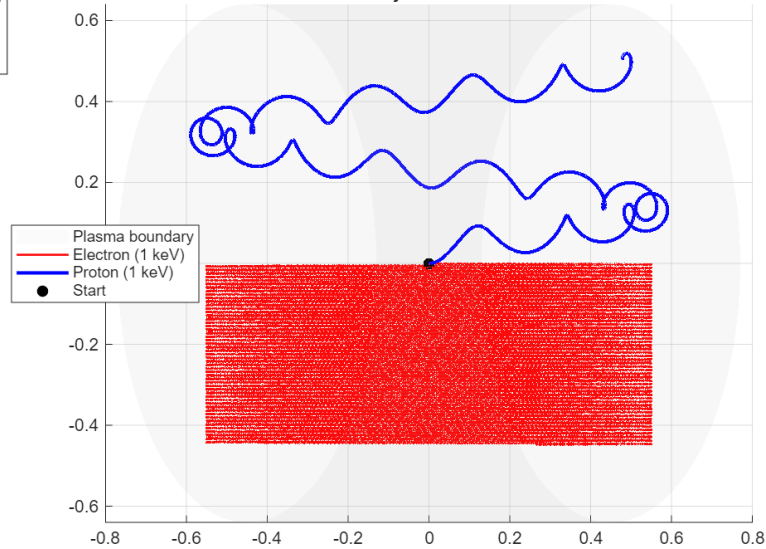

ne projection: electron and proton t

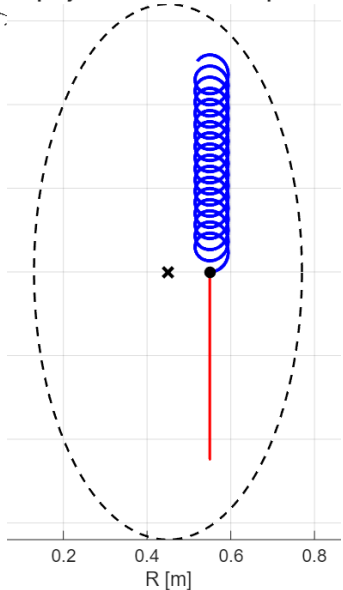

• Poloidal-plane projection

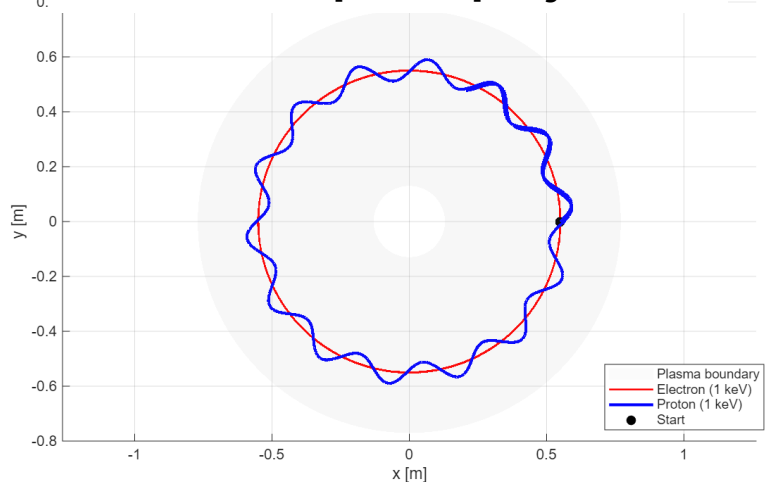



5. [10 points in total] A spherical tokamak with a major radius $R = 45$ cm, a minor radius $a = 32$ cm, and an elongation of $\kappa = 2$. The toroidal field $B_T = 0.1$ T at 45 cm. The plasma current $I_p = 0$. A electric field $E_z = -1000$ V/m in \hat{z} . A **proton** with an energy of 1 keV. Initial position at $R = 55$ cm.

Proton Orbit with $E_z < 0$ and Magnetic Field

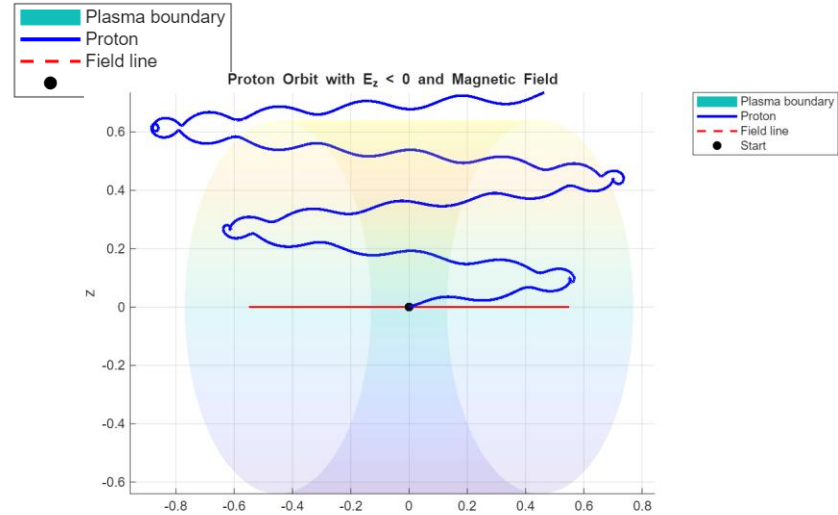
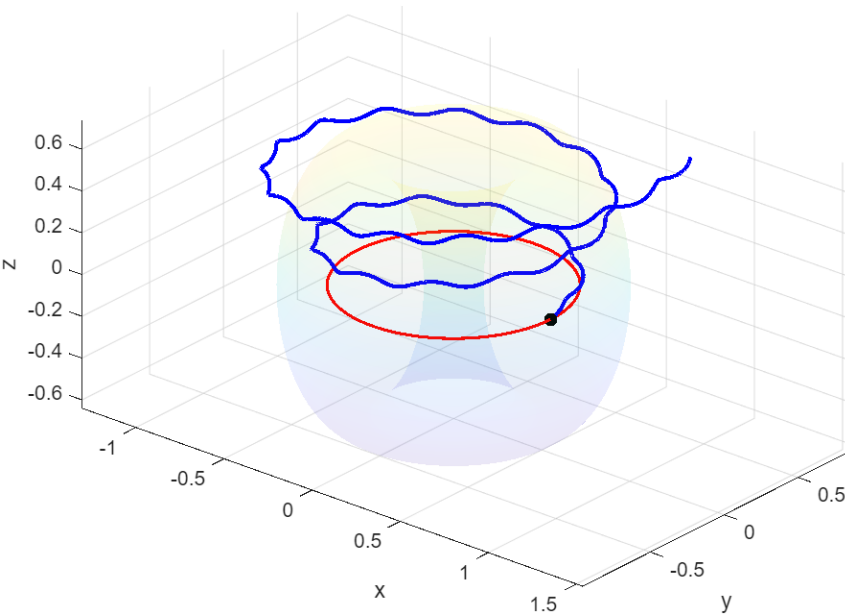

• Poloidal-plane projection

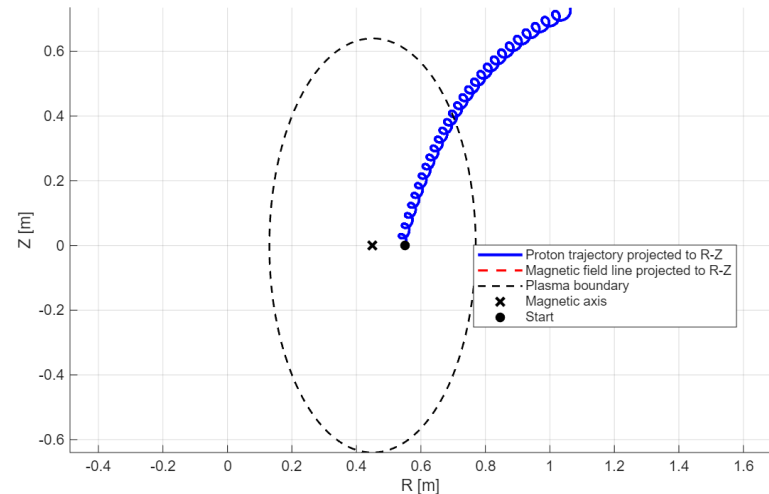
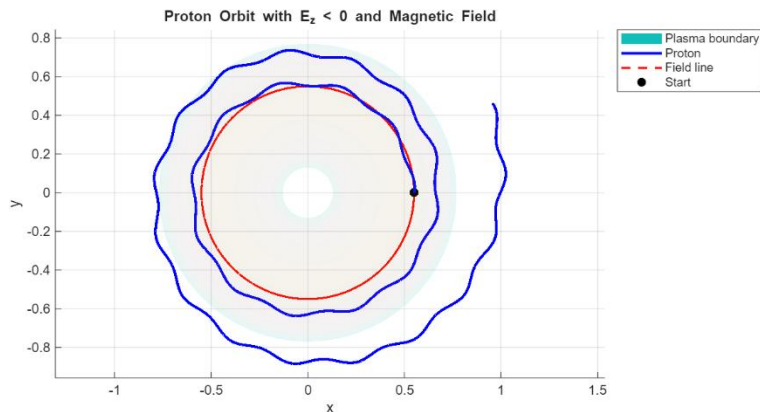



6. [10 points in total] A spherical tokamak with a major radius $R = 45$ cm, a minor radius $a = 32$ cm, and an elongation of $\kappa = 2$. The toroidal field $B_T = 0.1$ T at 45 cm. The plasma current $I_p = 0$. A electric field $E_z = -1000$ V/m in \hat{z} . An **electron** with an energy of 1 keV. Initial position at $R = 55$ cm. Please compare the result with condition 5.

Electron Orbit with $E_z < 0$ and Magnetic Field

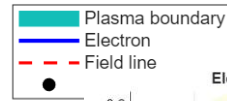
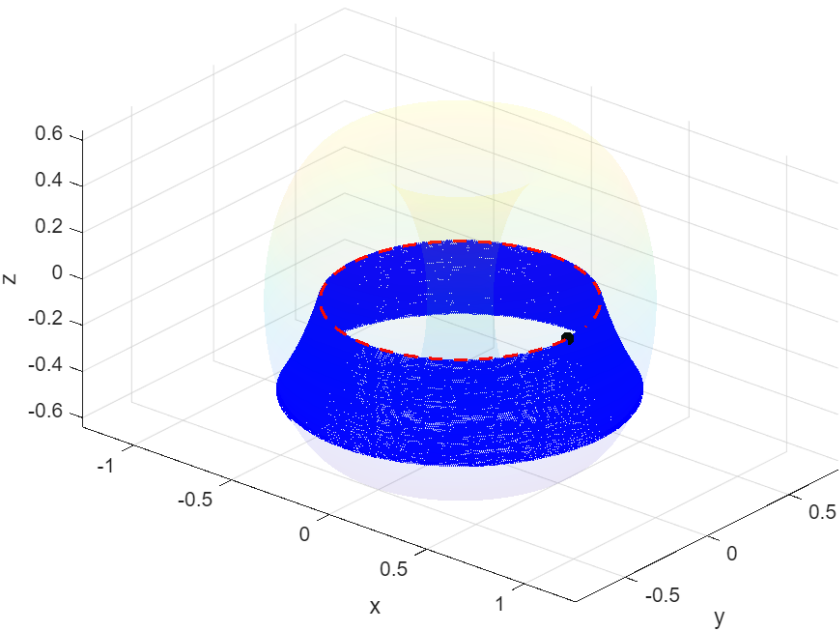

Electron Orbit with $E_z < 0$ and Magnetic Field

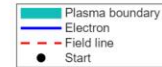
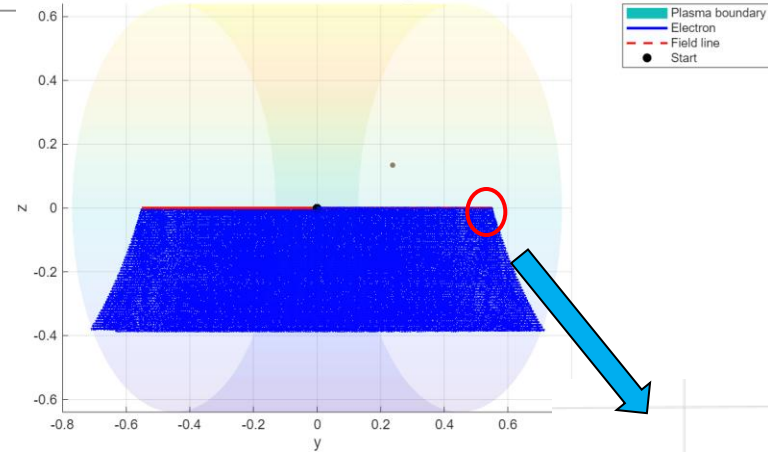

• Poloidal-plane projection

Electron Orbit with $E_z < 0$ and Magnetic Field

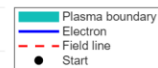
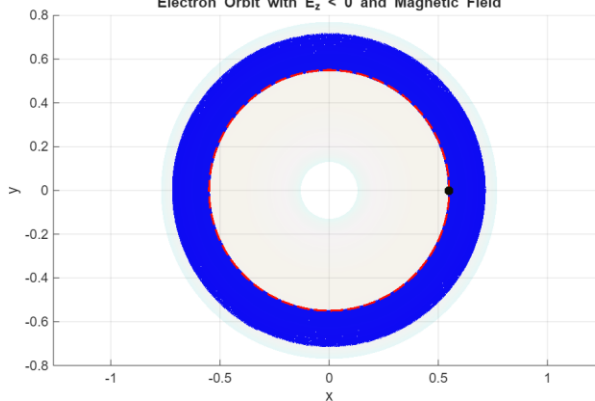

Poloidal-plane projection of electron trajectory

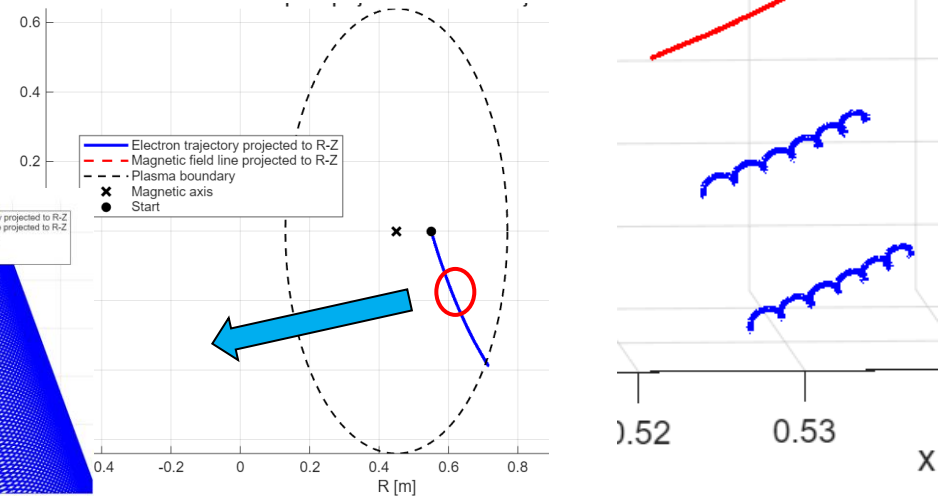
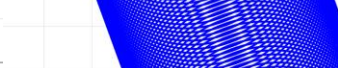
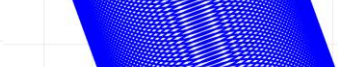
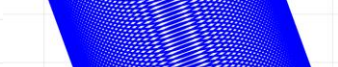
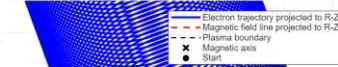



6. [10 points in total] A spherical tokamak with a major radius $R = 45$ cm, a minor radius $a = 32$ cm, and an elongation of $\kappa = 2$. The toroidal field $B_T = 0.1$ T at 45 cm. The plasma current $I_p = 0$. A electric field $E_z = -1000$ V/m in \hat{z} . An **electron** with an energy of 1 keV. Initial position at $R = 55$ cm. Please compare the result with condition 5.

Electron and Proton Orbits with $E_z < 0$ and Tokamak Magnetic Field

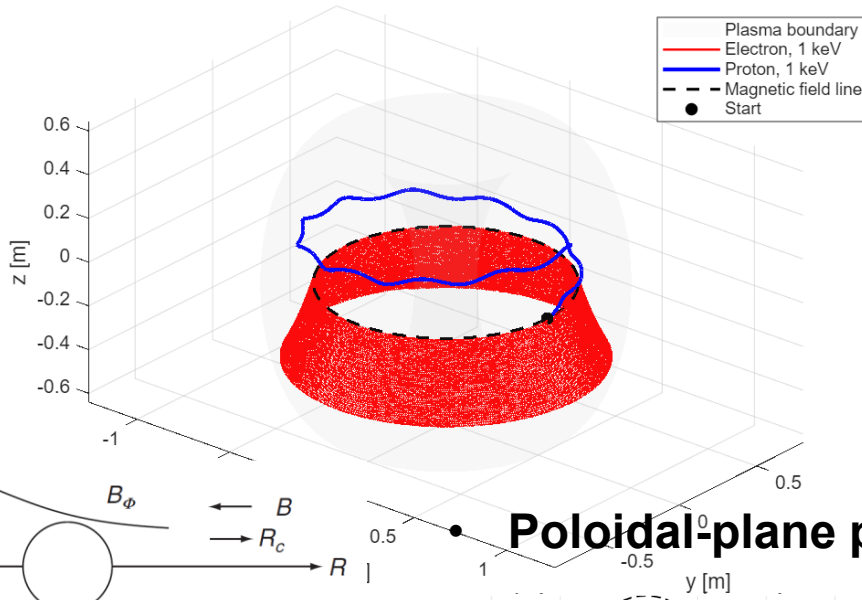

Electron and Proton Orbits with $E_z < 0$ and Tokamak Magnetic Field

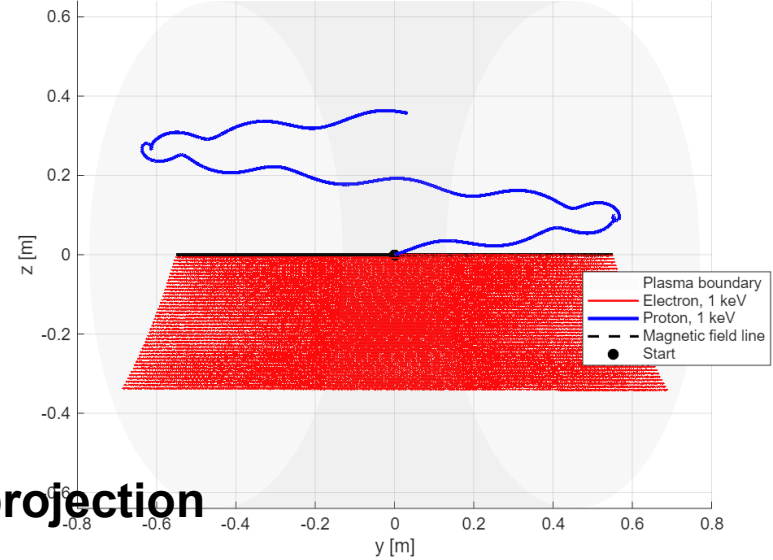

Poloidal-plane projection

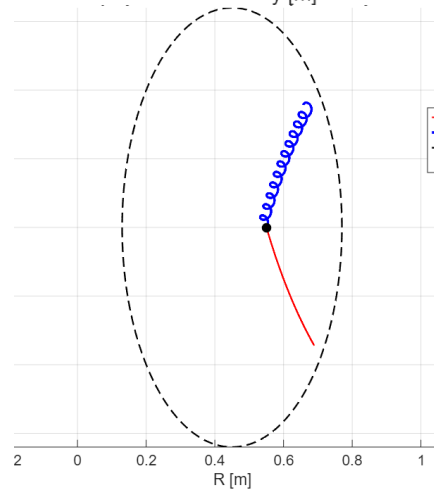
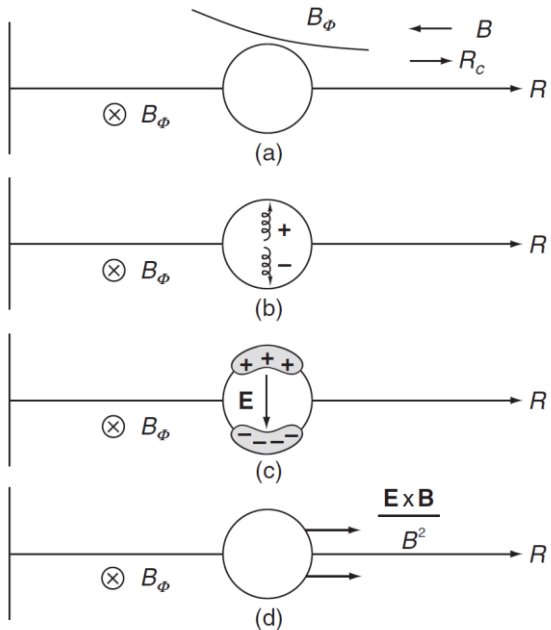

Top view: electron and proton trajectories

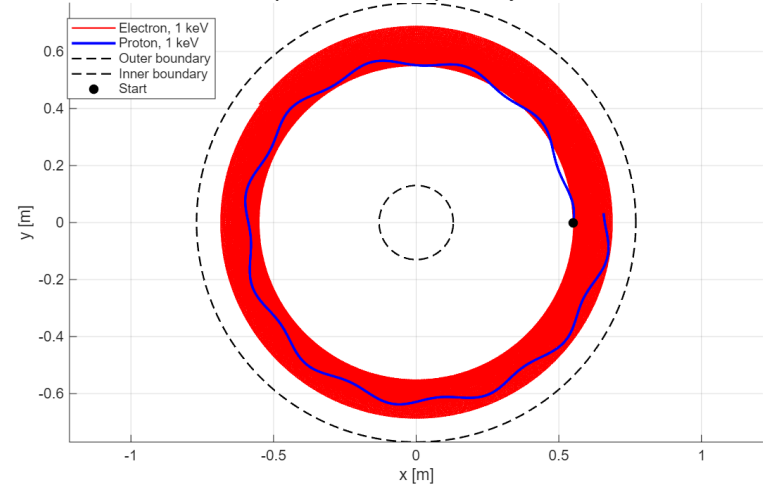



7. [10 points in total] A spherical tokamak with a major radius $R = 45$ cm, a minor radius $a = 32$ cm, and an elongation of $\kappa = 2$. The toroidal field $B_T = 0.1$ T at 45 cm. The plasma current $I_p = 100$ kA. A **proton** with an energy of 1 keV. Initial position at $R = 55$ cm.

Proton Orbit with $E_z < 0$ and Magnetic Field

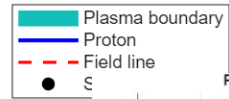
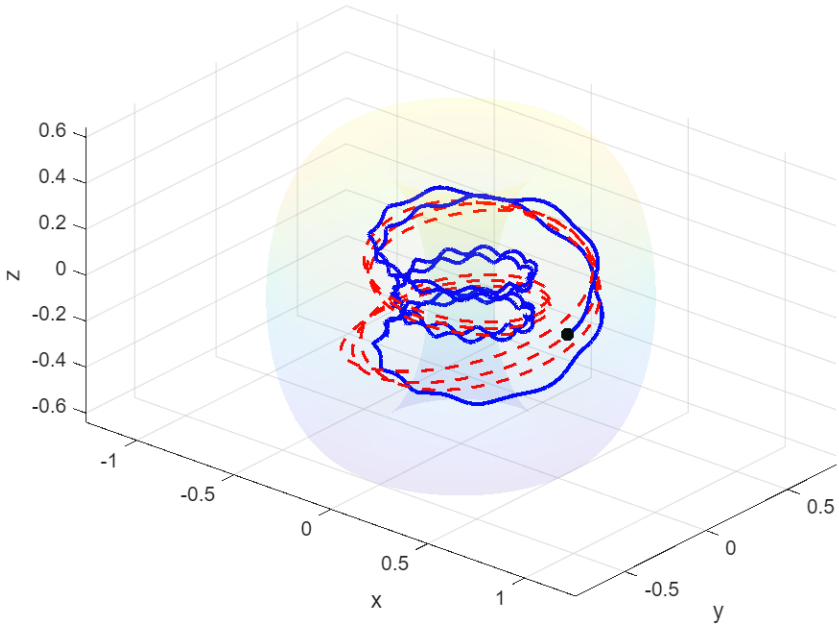

Proton Orbit with $E_z < 0$ and Magnetic Field

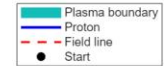
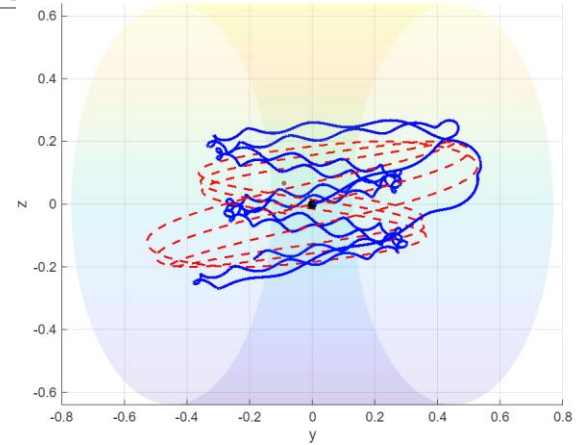

• Poloidal-plane projection

Proton Orbit with $E_z < 0$ and Magnetic Field

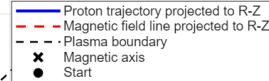
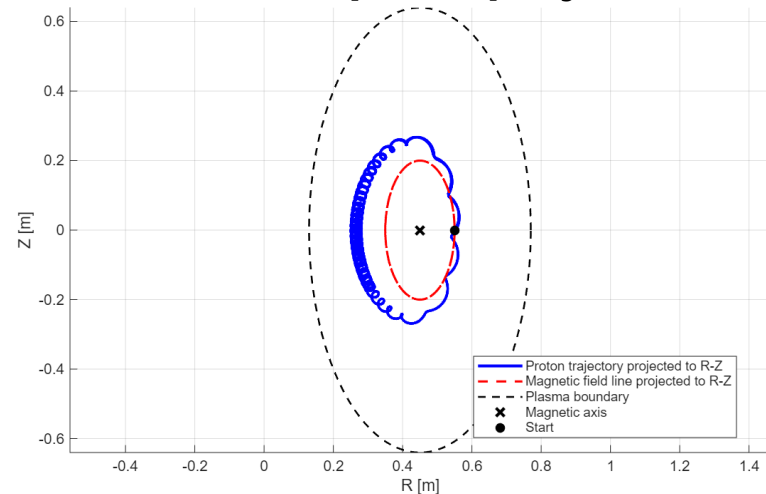
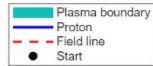
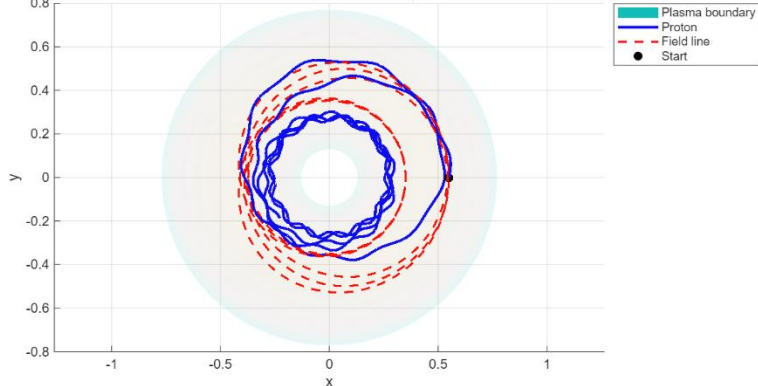



7. [10 points in total] A spherical tokamak with a major radius $R = 45$ cm, a minor radius $a = 32$ cm, and an elongation of $\kappa = 2$. The toroidal field $B_T = 0.1$ T at 45 cm. The plasma current $I_p = 100$ kA. A **proton** with an energy of 1 keV. Initial position at $R = 55$ cm.

Proton Orbit with $E_z < 0$ and Magnetic Field

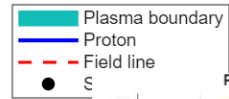
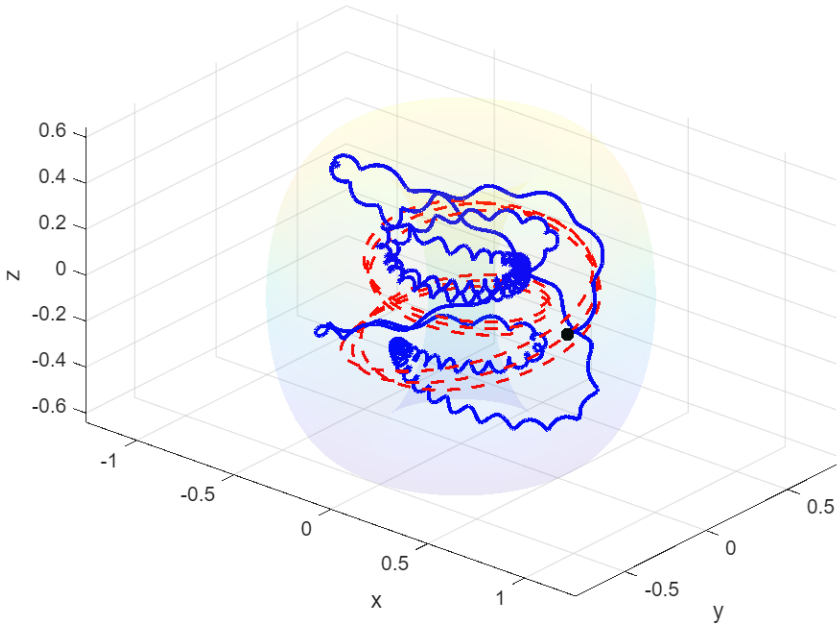

Proton Orbit with $E_z < 0$ and Magnetic Field

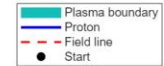
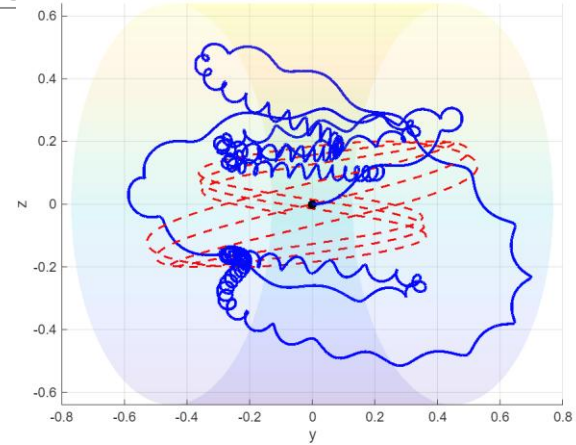

Proton Orbit with $E_z < 0$ and Magnetic Field

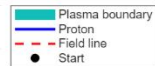
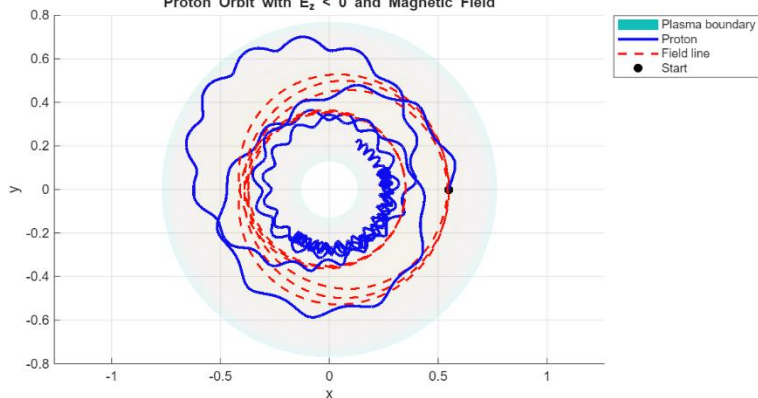

• Poloidal-plane projection

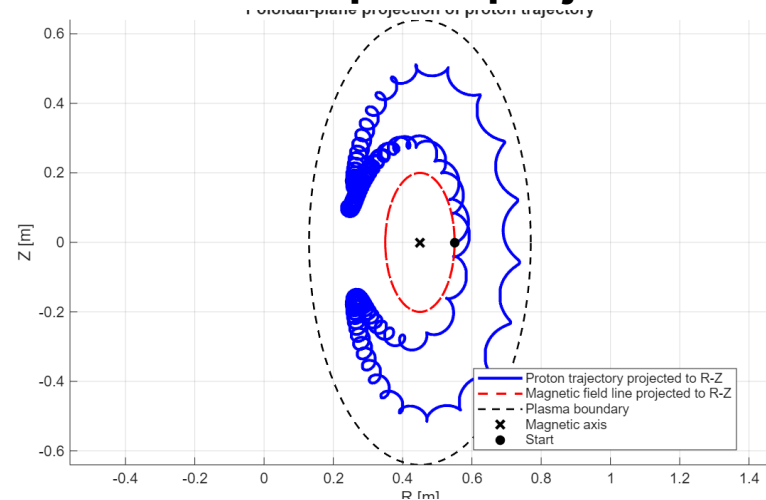

8. [10 points in total] A spherical tokamak with a major radius $R = 45$ cm, a minor radius $a = 32$ cm, and an elongation of $\kappa = 2$. The toroidal field $B_T = 0.1$ T at 45 cm. The plasma current $I_p = 100$ kA. An **electron** with an energy of 1 keV. Initial position at $R = 55$ cm. Please compare the result with condition 7.



Electron Orbit with $E_z < 0$ and Magnetic Field

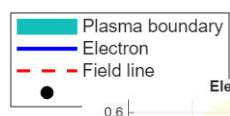
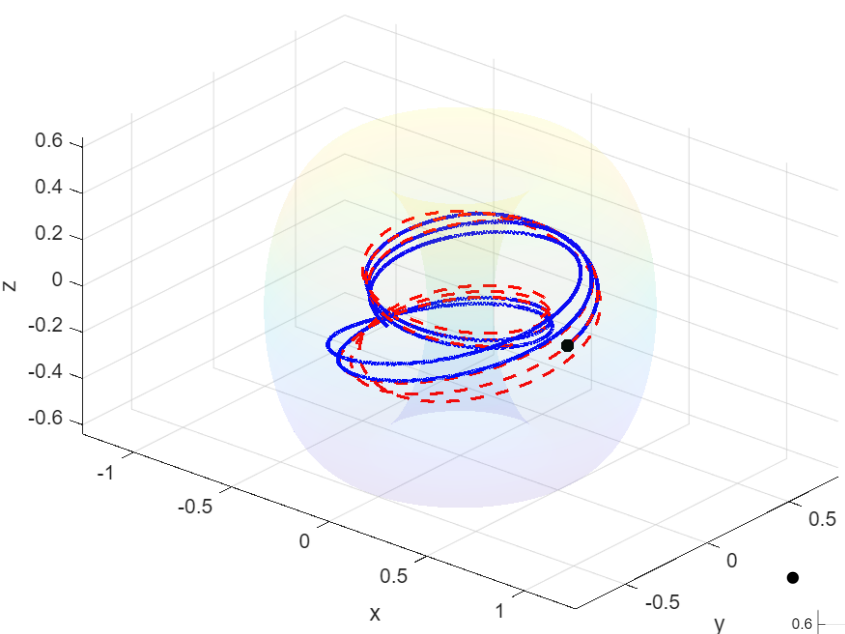

Electron Orbit with $E_z < 0$ and Magnetic Field

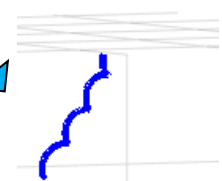
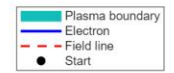
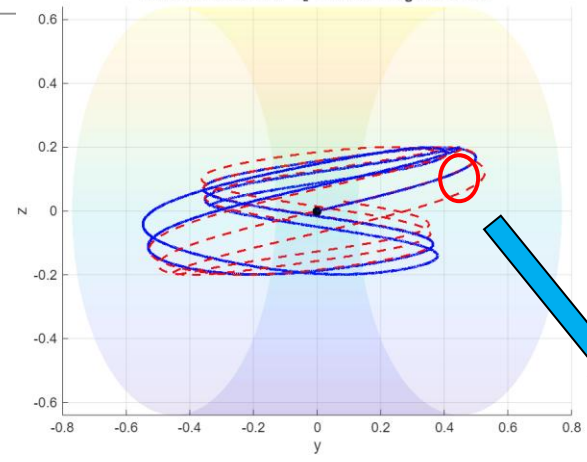

• Poloidal-plane projection

Electron Orbit with $E_z < 0$ and Magnetic Field

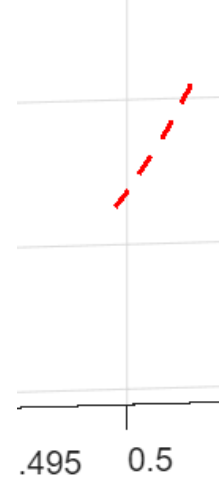
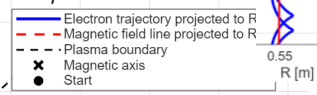
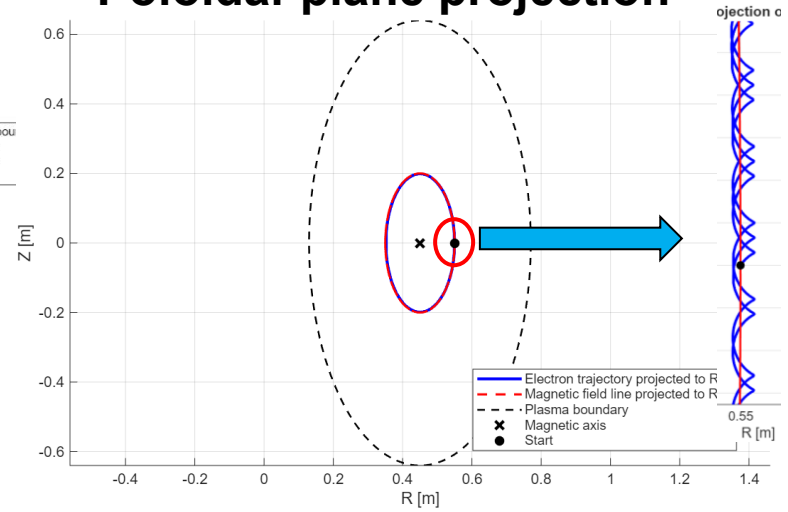
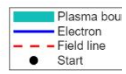
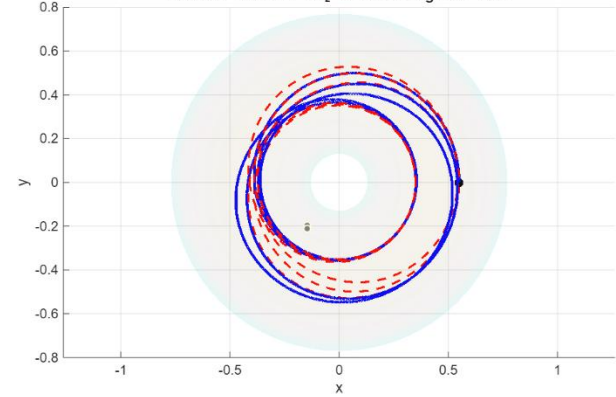

8. [10 points in total] A spherical tokamak with a major radius $R = 45$ cm, a minor radius $a = 32$ cm, and an elongation of $\kappa = 2$. The toroidal field $B_T = 0.1$ T at 45 cm. The plasma current $I_p = 100$ kA. An **electron** with an energy of 1 keV. Initial position at $R = 55$ cm. Please compare the result with condition 7.



Electron and Proton Orbits with $B_t + B_p$ Tokamak Magnetic Field

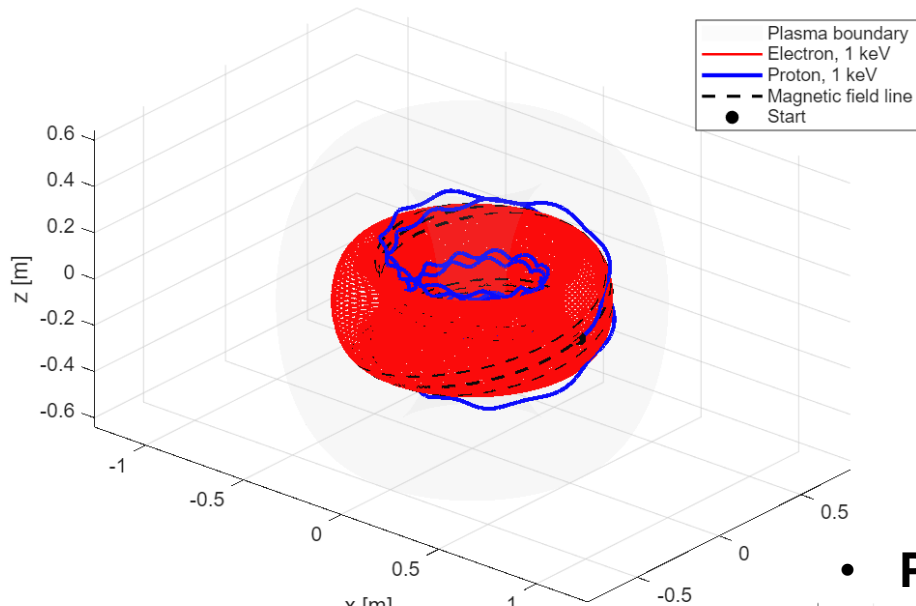

Electron and Proton Orbits with $B_t + B_p$ Tokamak Magnetic Field

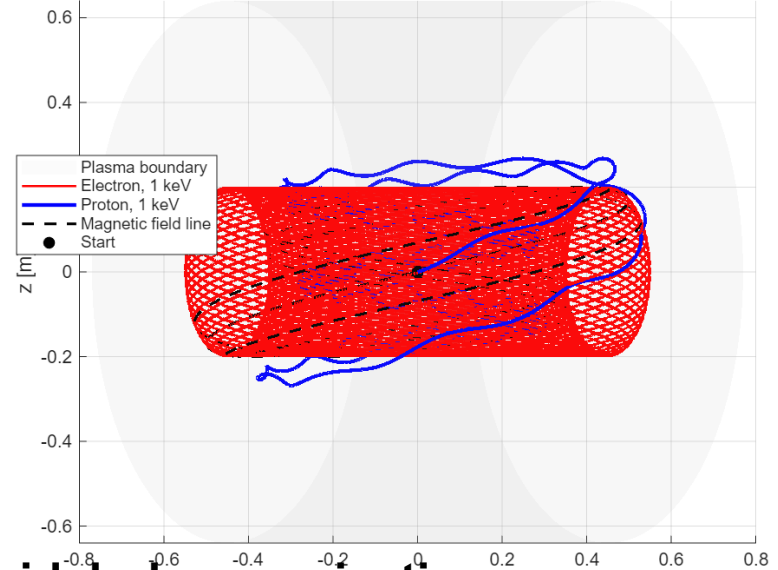

• Poloidal-plane projection

Top view: electron and proton trajectories with $B_t + B_p$

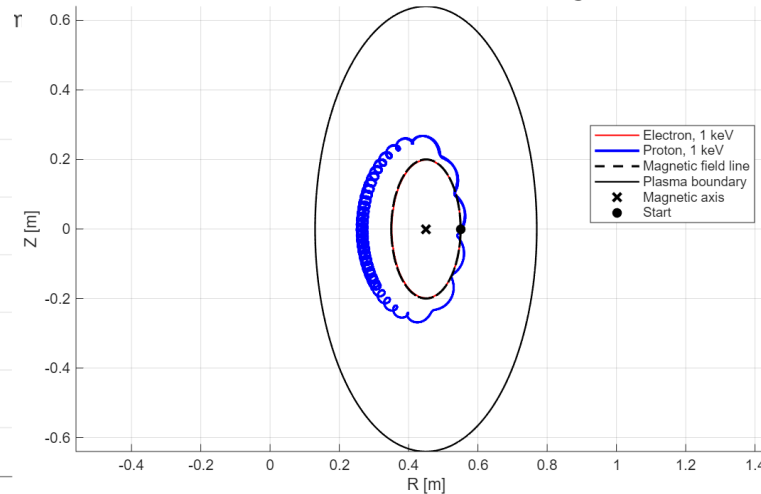
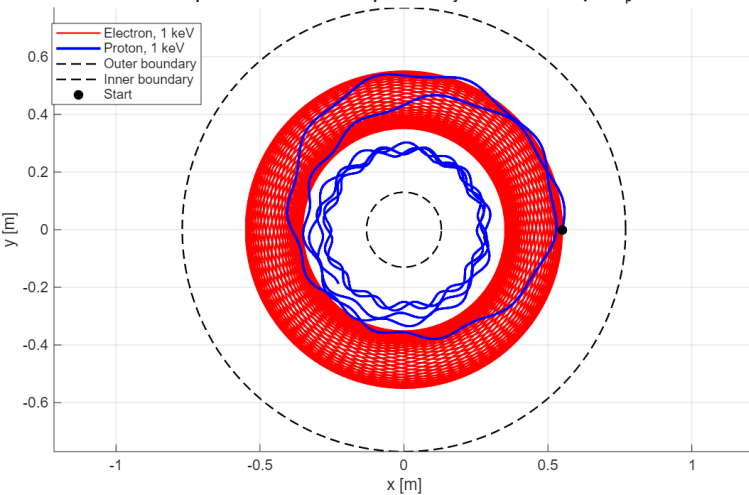

Plasma current plays an important role for confinement



- W/O plasma current
- W/ plasma current

Poloidal projection: electron and proton trajectories

Poloidal projection: electron and proton traj

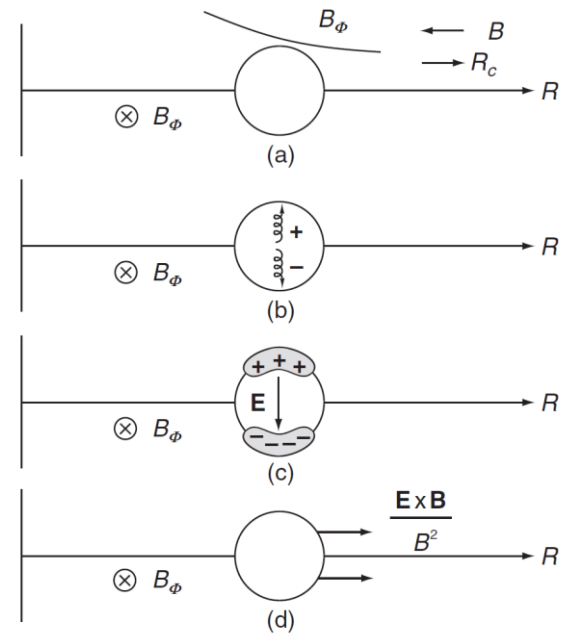
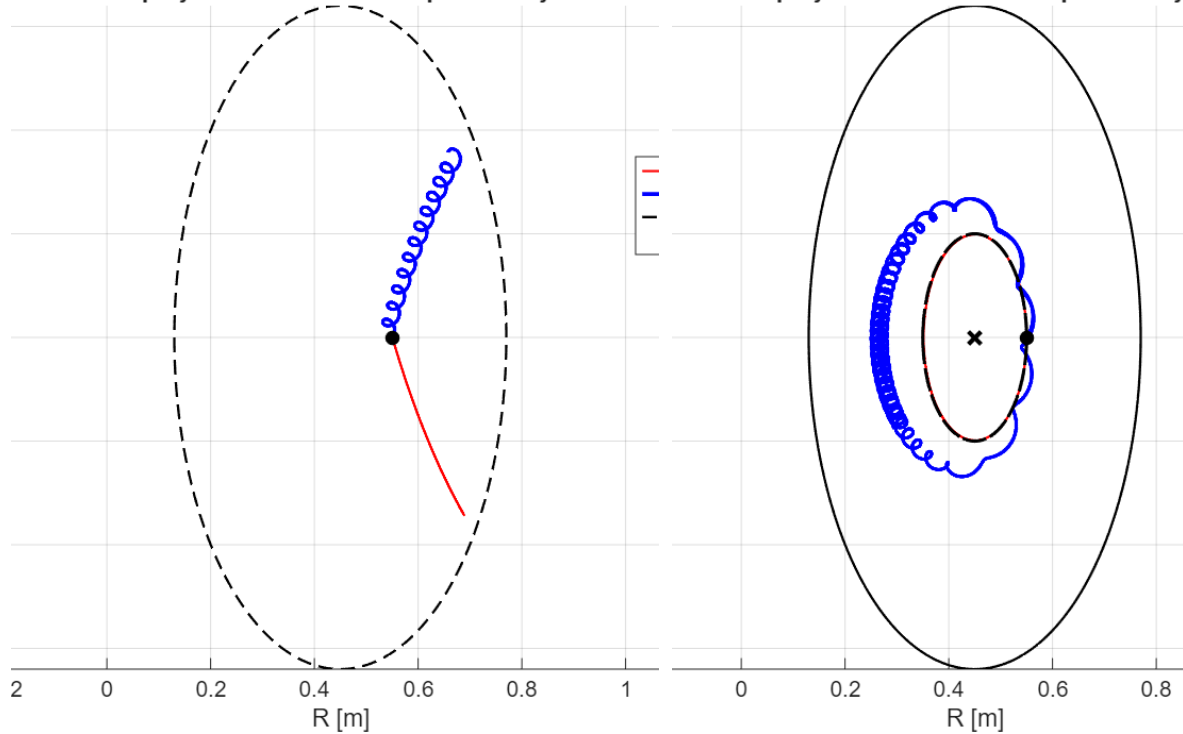

9. [10 points in total] To confine the plasma in a Tokamak, magnetic fields are helical as shown in the following figure (a). Please use the following figure (b) to explain why the plasma can be confined.

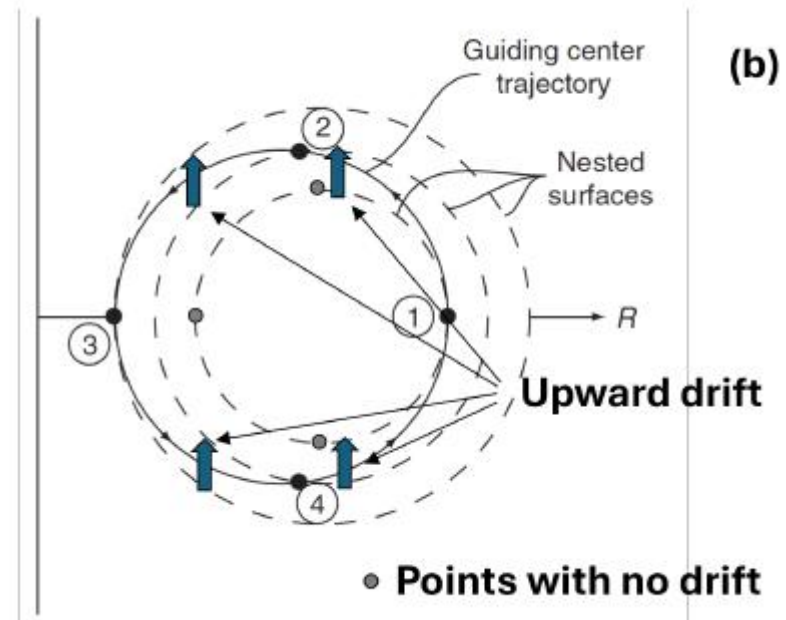
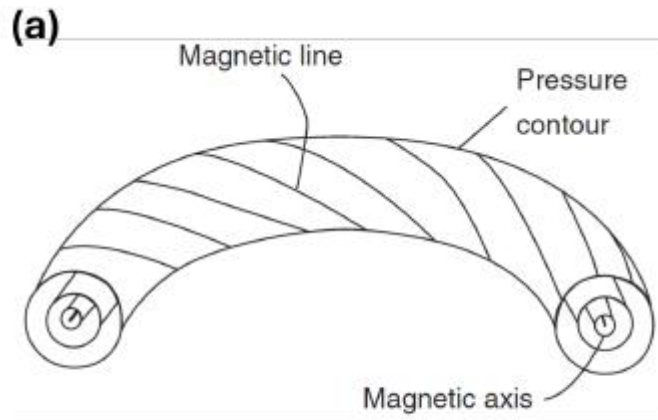

10. [25 points in total] Shown in the following figures are the particle trajectories in a Tokamak. Figure (a) is the trajectory of the passing particle, while figure (b) is the projection of the trajectory of the passing particle on the poloidal plane. Figure (c) is the trajectory of the bouncing particle, while figure (d) is the projection of the trajectory of the bouncing particle on the poloidal plane, which is called the banana orbit. Please answer the following questions: (a) When a charged particle follows a field line, why does it experience a nonuniform toroidal magnetic field? [5 points] (b) Since the toroidal magnetic field is not a constant along the particle's trajectory, the "mirror effect" occurs. Why are there two categories of particle trajectories? What determines if particles are bouncing or passing? [10 points] (c) If there is no drift, what does Fig. (b) look like? [5 points] (d) If there is no drift, what does Fig. (d) look like? [5 points]

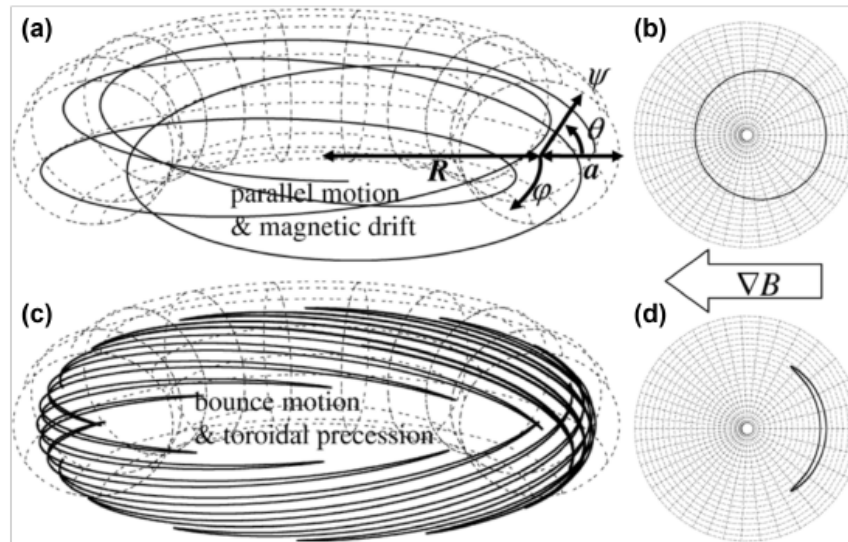

11. [10 points in total] Shown in the following figure are two adjacent banana orbits. A bootstrap current can be generated when the number of particles in two adjacent banana orbits is different. Please explain (a) why banana orbits are essential for generating bootstrap currents. [5 points] and (b) why a bootstrap current can be generated when a pressure gradient across two adjacent banana orbits occurs. [5 points]

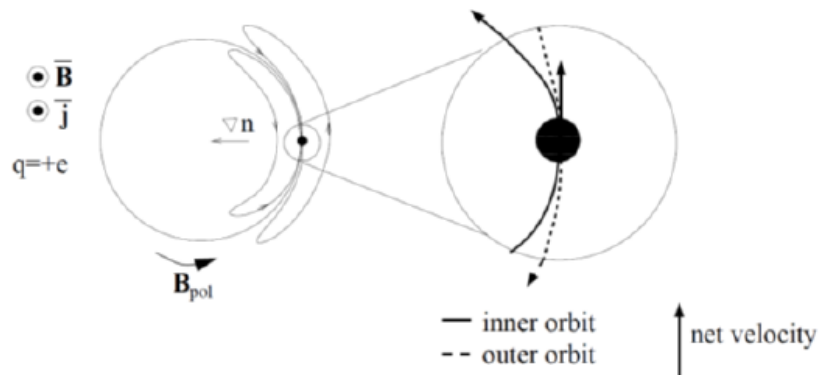

With poloidal fields, charged particles see nonuniform toroidal magnetic field



- W/o poloidal field

$$R_1 = R_2$$

$$B_{T1} = B_{T2}$$

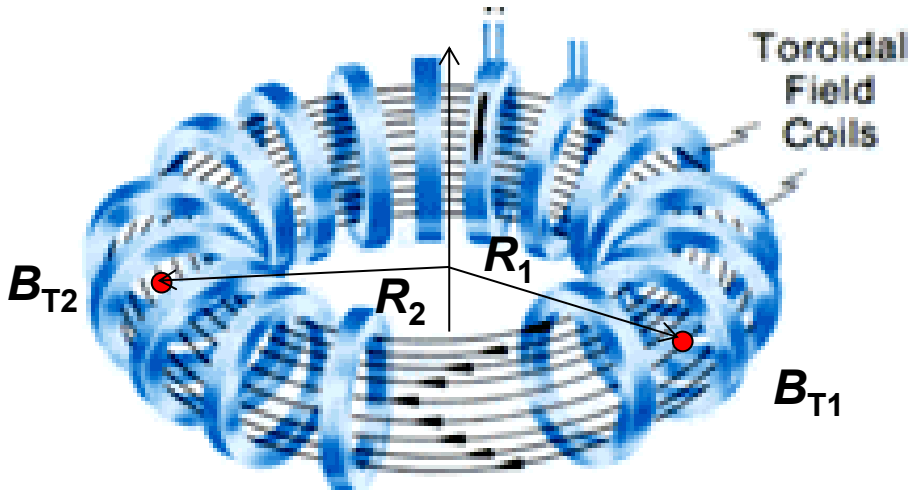

$$B_T \propto \frac{1}{R}$$

$$B_T \gg B_p$$

- W/ poloidal field

$$R_1 > R_2$$

$$B_{T1} < B_{T2}$$

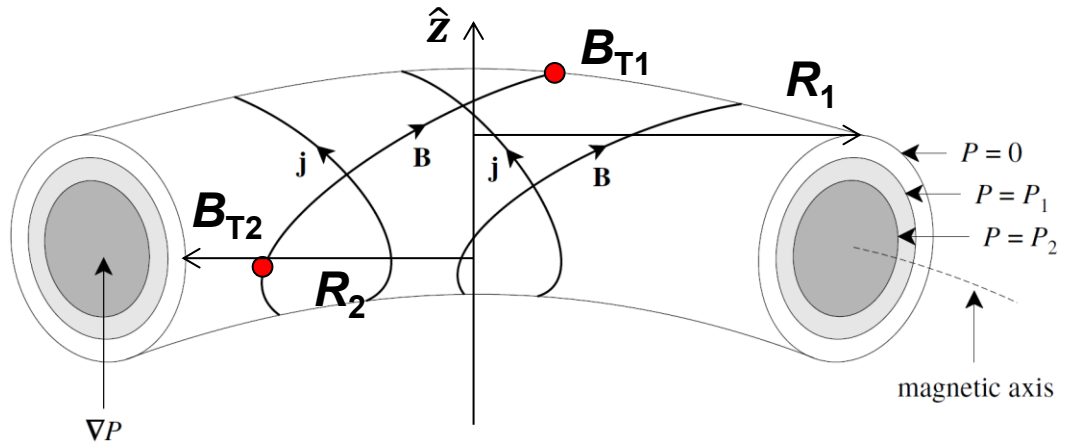

Charged particles can be partially confined by a magnetic mirror machine



- Charged particles with small v_{\parallel} eventually stop and are reflected while those with large v_{\parallel} escape.

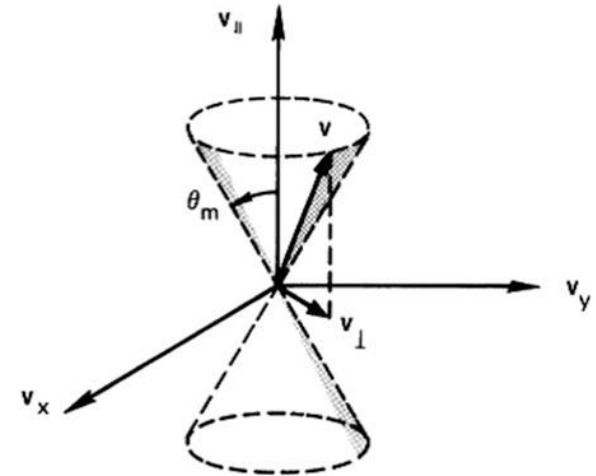
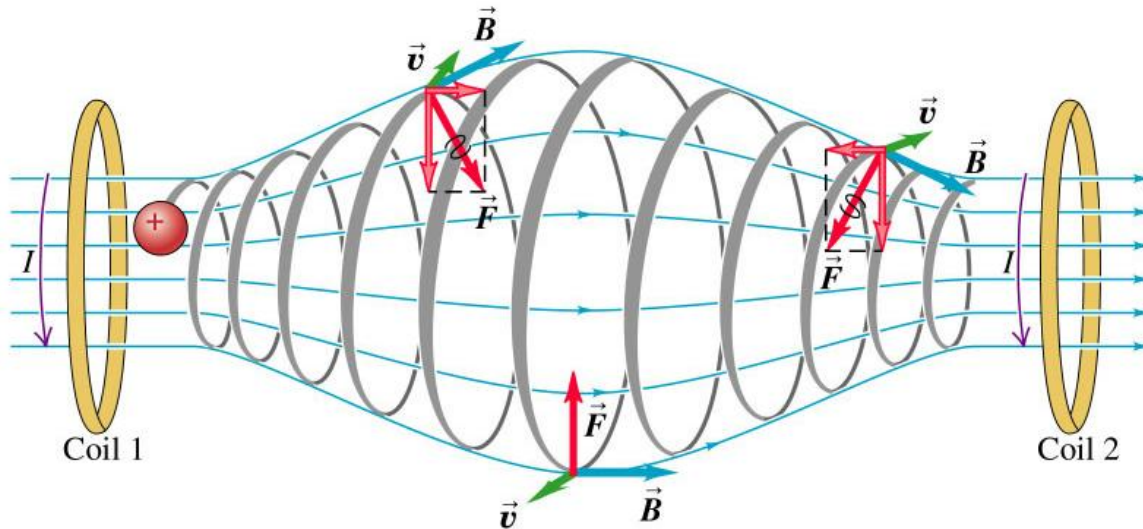

$$\frac{1}{2}mv^2 = \frac{1}{2}mv_{\parallel}^2 + \frac{1}{2}mv_{\perp}^2 \quad \text{Invariant: } \mu \equiv \frac{1}{2} \frac{mv_{\perp}^2}{B}$$

$$v'_{\perp}{}^2 = v_{\perp 0}^2 + v_{\parallel 0}^2 \equiv v_0^2$$

$$\frac{B_0}{B'} = \frac{v_{\perp 0}^2}{v'_{\perp}{}^2} = \frac{v_{\perp 0}^2}{v_0^2} \equiv \sin^2 \theta$$

$$\frac{B_0}{B_m} \equiv \frac{1}{R_m} = \sin^2 \theta_m$$

- Large v_{\parallel} may occur from collisions between particles.

• Those confined charged particle are eventually lost due to collisions.

Parallel velocity changes when particles follow field the field line

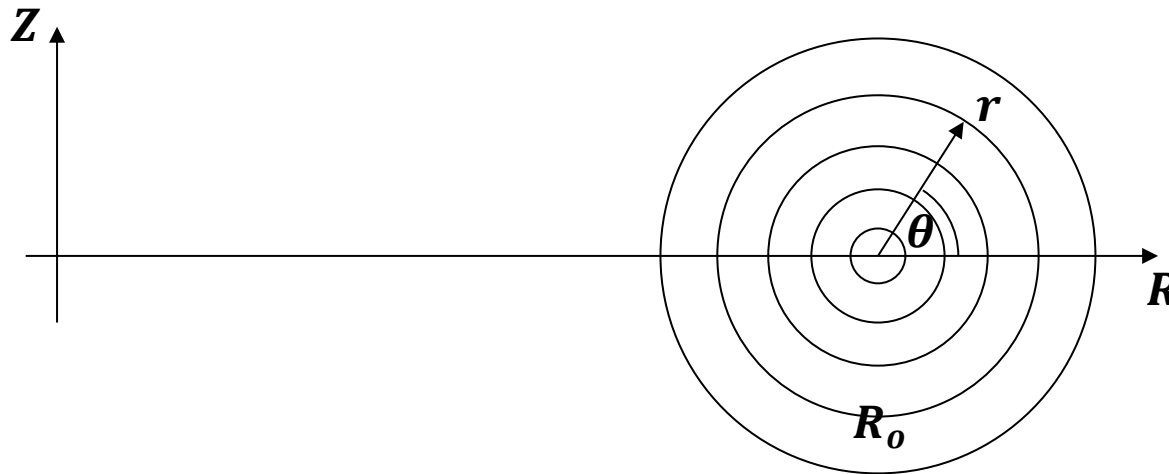

$$R \gg r$$

$$B_T \gg B_p$$

$$R = R_0 + r \cos \theta = R_0(1 + \epsilon \cos \theta)$$

Inverse aspect ratio:

$$\epsilon \equiv \frac{r}{R_0}$$

$$B \simeq \frac{B_0}{1 + \epsilon \cos \theta} \simeq B_0(1 - \epsilon \cos \theta)$$

Invariant: $\mu \equiv \frac{1}{2} \frac{mv_{\perp}^2}{B} = \frac{v_{\perp}^2}{B_0(1 - \epsilon \cos \theta)} = \frac{v_{\perp 0}^2}{B_0(1 - \epsilon)}$

$$v_{\perp}^2 = \frac{v_{\perp 0}^2(1 - \epsilon \cos \theta)}{1 - \epsilon}$$

$$v^2 = v_{\perp}^2 + v_{\parallel}^2 = v_{\perp 0}^2 + v_{\parallel 0}^2$$

$$v_{\parallel}^2 = v^2 \left(1 - \frac{v_{\perp 0}^2}{v^2} \frac{(1 - \epsilon \cos \theta)}{1 - \epsilon} \right)$$

$$\approx v^2 \left(1 - \frac{v_{\perp 0}^2}{v^2} \left(1 + 2\epsilon \sin^2 \left(\frac{\theta}{2} \right) \right) \right)$$

$$v_{\parallel}^2 = v^2 \left(1 - \frac{v_{\perp}^2}{v^2} \right)$$

Particles may be trapped by nonuniform magnetic field

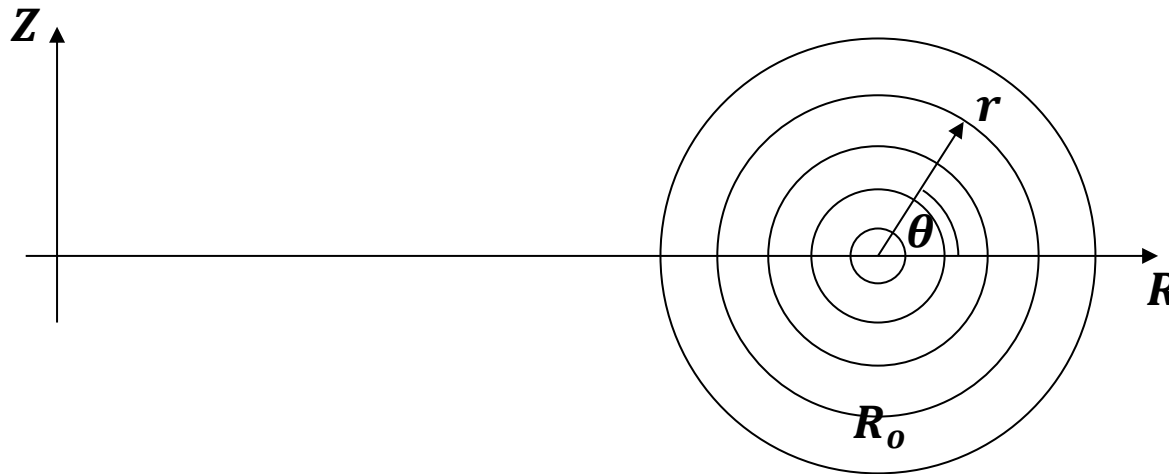

$$R \gg r$$
$$B_T \gg B_p$$

$$\epsilon \equiv \frac{r}{R_0}$$

$$v_{\parallel}^2 \approx v^2 \left(1 - \frac{v_{\perp 0}^2}{v^2} \left(1 + 2\epsilon \sin^2 \left(\frac{\theta}{2} \right) \right) \right)$$

- For $v_{\parallel}^2 \geq 0$, particles are passing.
- For $v_{\parallel}^2 \leq 0$, particles are trapped.

Charge particles drift across magnetic field lines when the magnetic field is not uniform or curved



- Gradient-B drift

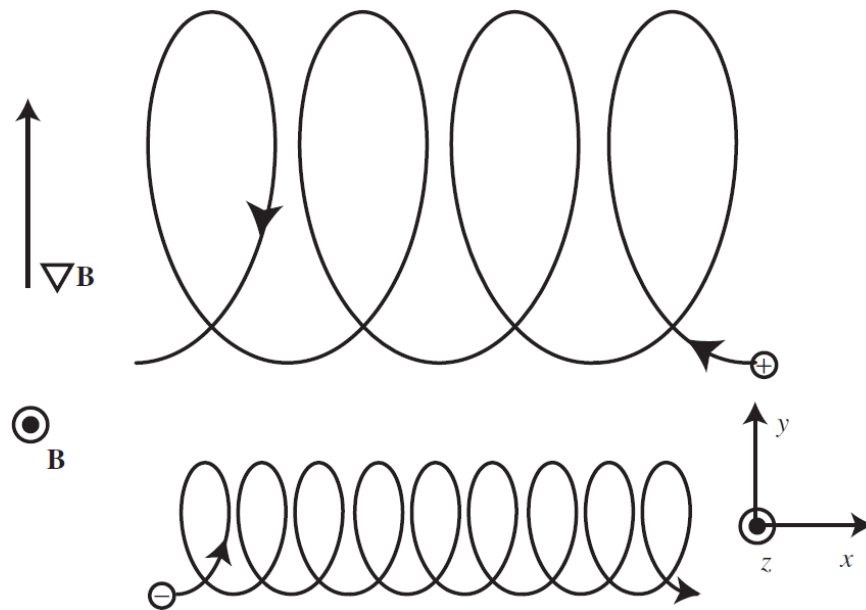

$$\vec{v}_{\nabla} = \frac{mv_{\perp}^2}{2q} \frac{\vec{B} \times \nabla B}{B^3}$$

- Curvature drift

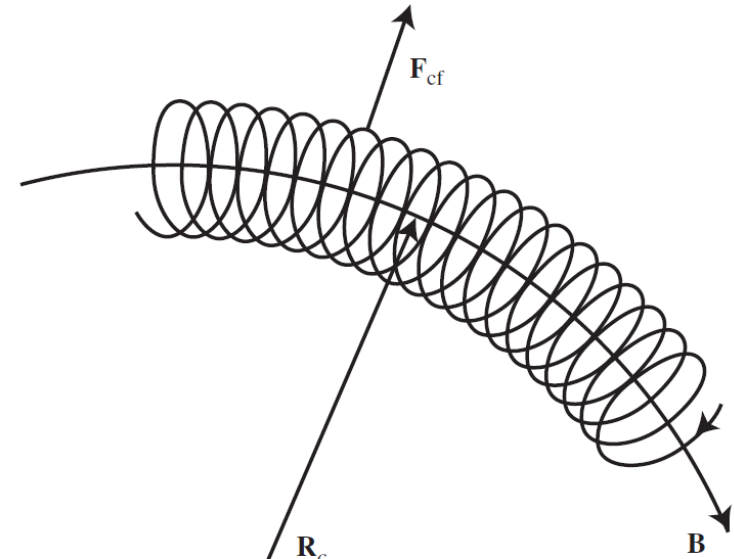

$$\vec{v}_R = \frac{mv_{\parallel}^2}{2q} \frac{\vec{R}_c \times \vec{B}}{R_c B^2}$$

$$\vec{v}_{\text{total}} = \vec{v}_R + \vec{v}_{\nabla} = \frac{\vec{B} \times \nabla B}{\omega_c B^2} \left(v_{\parallel}^2 + \frac{1}{2} v_{\perp}^2 \right) = \frac{m}{q} \frac{\vec{R}_c \times \vec{B}}{R_c^2 B^2} \left(v_{\parallel}^2 + \frac{1}{2} v_{\perp}^2 \right)$$

For passing particles, they drift back to the original position with a “semicircle” orbit



$$\vec{v}_{\text{total}} = \vec{v}_R + \vec{v}_\nabla = \frac{\vec{B} \times \nabla B}{\omega_c B^2} \left(v_{\parallel}^2 + \frac{1}{2} v_{\perp}^2 \right) = \frac{m}{q} \frac{\vec{R}_c \times \vec{B}}{R_c^2 B^2} \left(v_{\parallel}^2 + \frac{1}{2} v_{\perp}^2 \right)$$

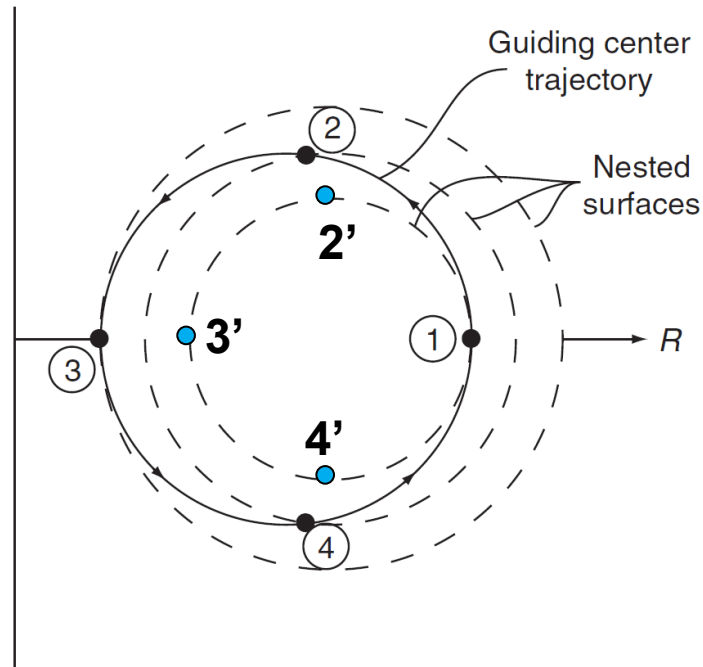

For trapped particles, they drift back to the original position with a banana orbit



- W/o drifting

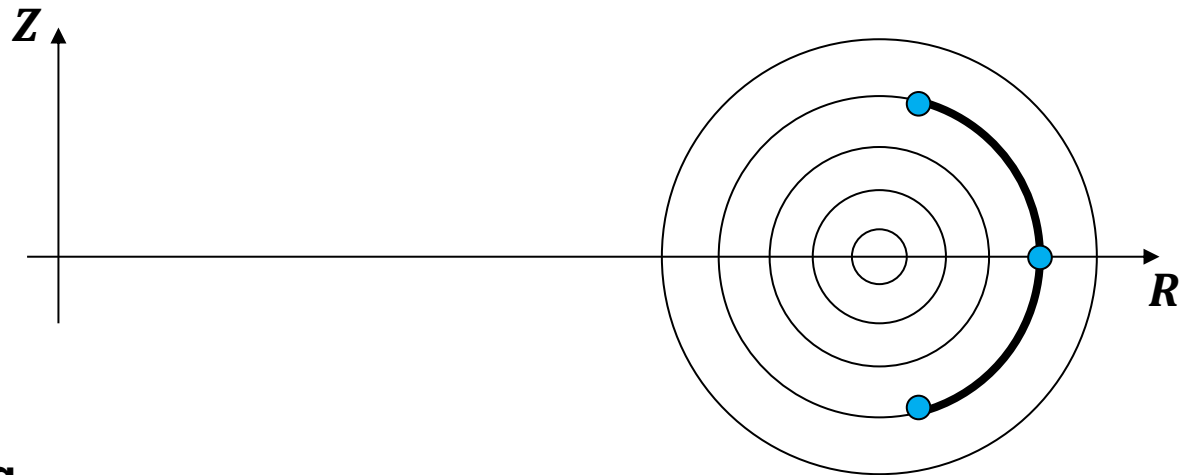

- W/ drifting

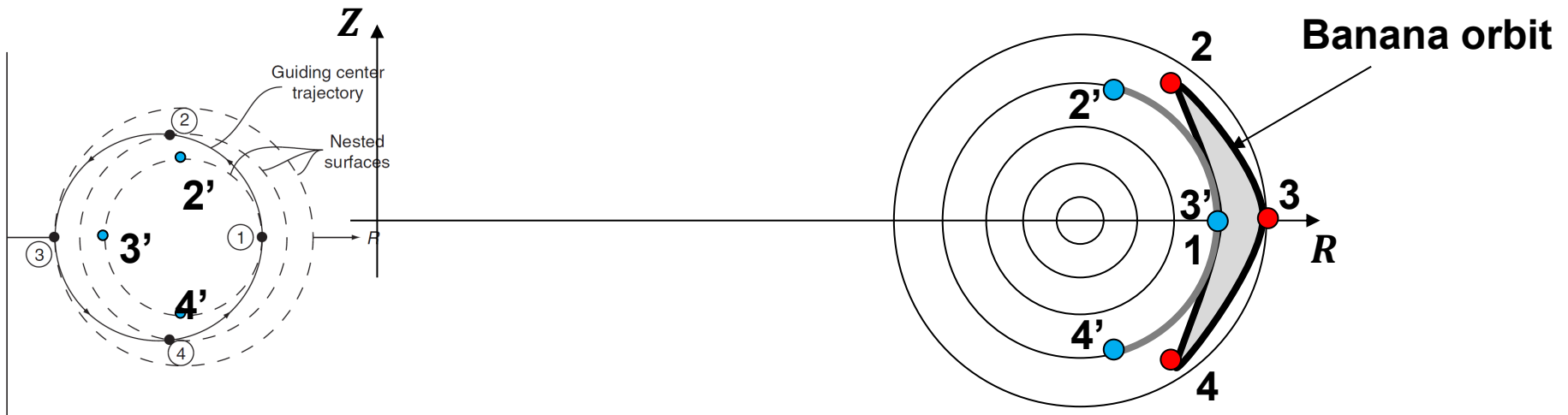

Trajectories of charged particles

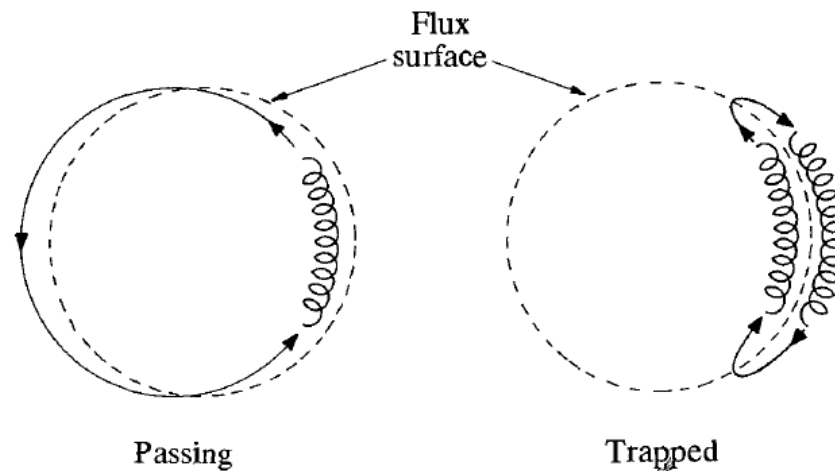
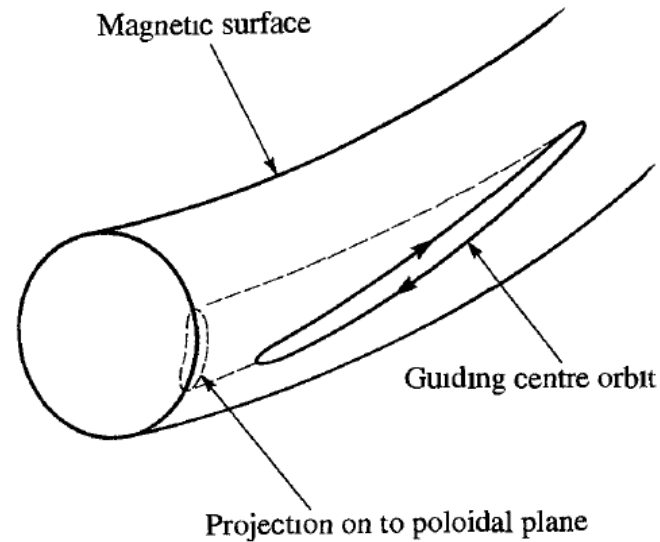

The trajectories of charged particles follow the toroidal field lines

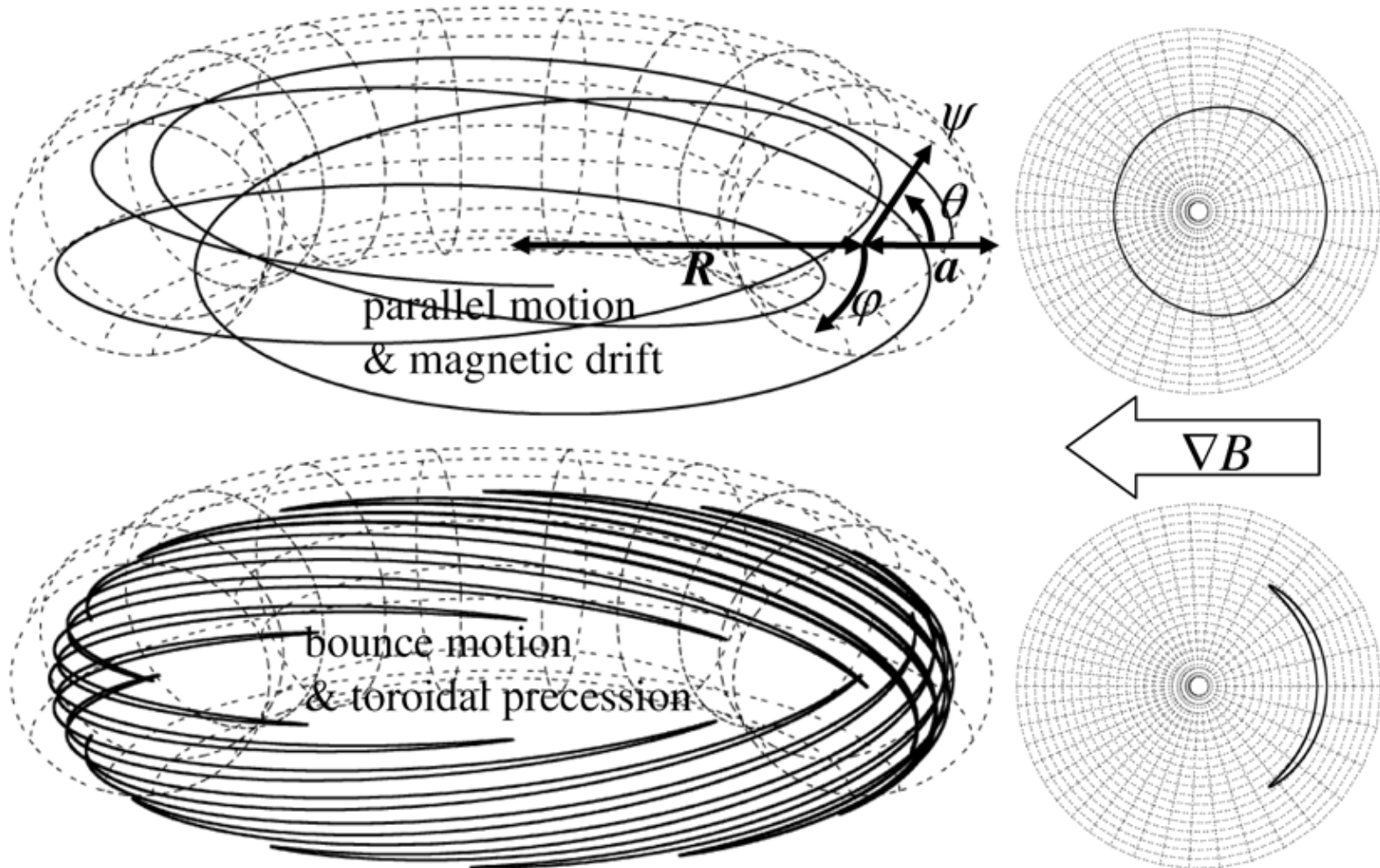

A banana current is generated when there is a pressure gradient in the plasma

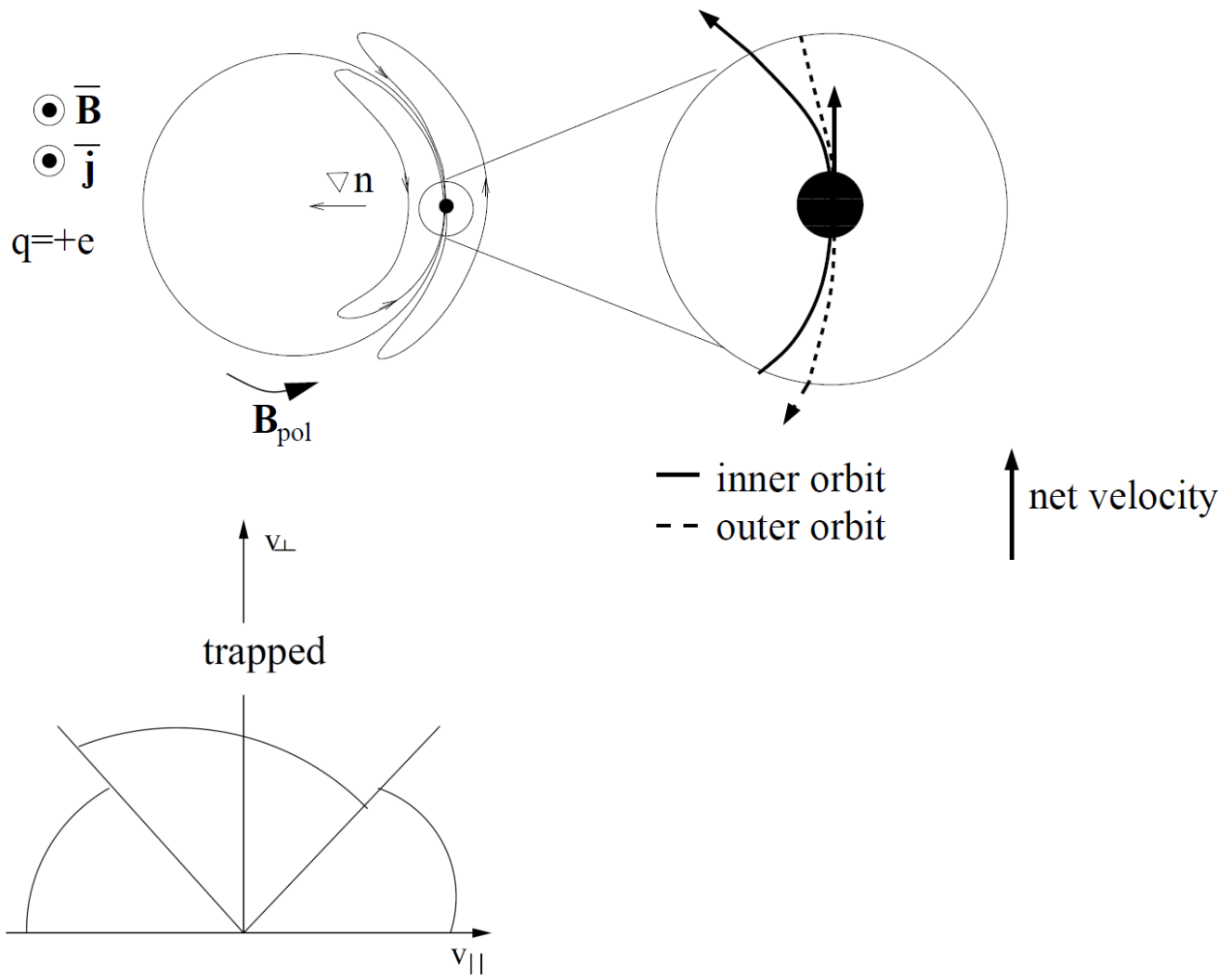

Bootstrap current is generated when passing particles are scattered by the trapped particles



- Scattering smooths the velocity distribution and shifts it in the parallel direction, i.e., a current is generated. It is called the bootstrap current.

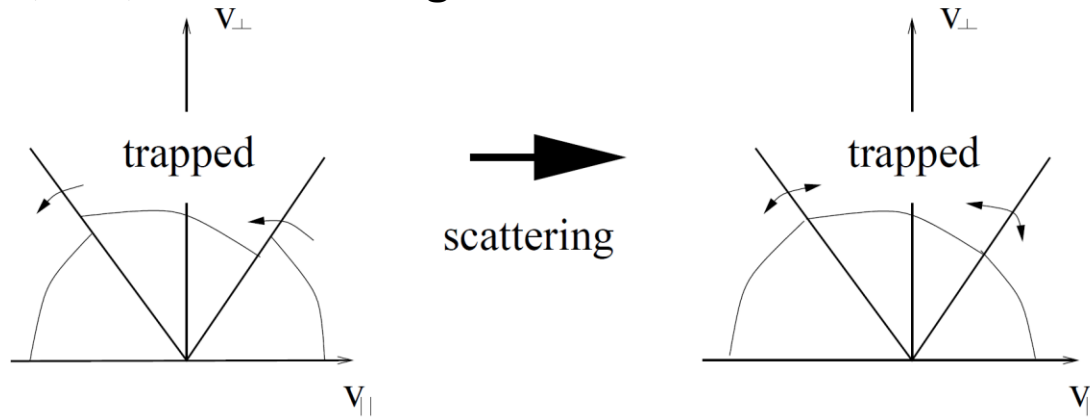

$$j = -enu_{||e} + enu_{||i} = 4\epsilon^{3/2} \frac{1}{B_p} T \frac{dn}{dr}$$

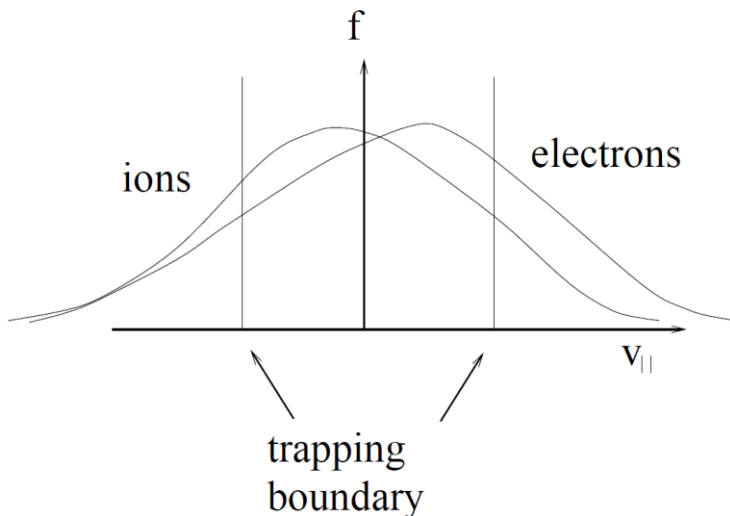

- The bootstrap current is vital for steady-state operation.

When forces are balanced, the system is in the equilibrium state, or called “Magnetohydrostatics”



- Equilibrium state:

$$\rho_m \left[\frac{\partial \vec{v}}{\partial t} + (\vec{v} \cdot \nabla) \vec{v} \right] = \vec{j} \times \vec{B} - \nabla p \equiv 0$$

$$\vec{j} \times \vec{B} = \nabla p$$

$$\vec{j} \times \vec{B} = \frac{1}{\mu_0} (\nabla \times \vec{B}) \times \vec{B} = \frac{1}{\mu_0} \left[(\vec{B} \cdot \nabla) \vec{B} - \frac{1}{2} \nabla B^2 \right] = \nabla p$$

$$\nabla \times \vec{B} = \mu_0 \vec{j}$$

$$\nabla \left(p + \frac{B^2}{2\mu_0} \right) = \frac{1}{\mu_0} (\vec{B} \cdot \nabla) \vec{B}$$

Magnetic
pressure

Magnetic
tension

← Forces caused by
curvature of the field lines

$$\vec{j} \perp \nabla p \quad \vec{B} \perp \nabla p \quad \Rightarrow \quad \vec{j} \cdot \nabla p = 0 \quad \vec{B} \cdot \nabla p = 0$$

- The surfaces with $p = \text{constant}$ are both magnetic surfaces (i.e., they are made up of magnetic field lines) and current surfaces (i.e., they are made of current flow lines).

Plasma condition can be obtained by solving Grad-Shafranov equation



$$\Delta^* \psi = -\mu_0 R^2 \frac{dp}{d\psi} - \frac{1}{2} \frac{dF^2}{d\psi} \quad \text{where } \Delta^* \psi = R^2 \nabla \cdot \left(\frac{\nabla \psi}{R^2} \right) \quad \mu_0 j_\phi = -\frac{1}{R} \Delta^* \psi$$
$$j_\phi = R \frac{dp}{d\psi} + \frac{1}{2\mu_0 R} \frac{dF^2}{d\psi}$$

- The usual strategy to solve the Grad-Shafranov equation:
 1. Specify two free functions, the plasma pressure $p = p(\psi)$ and the toroidal field function $F = F(\psi)$.
 2. Solve the equation with specified boundary conditions to determine the flux function $\psi(R, z)$.
 3. Calculation the magnetic field using the following equations:

$$B_R = -\frac{1}{R} \frac{\partial \psi}{\partial z} \quad B_\phi = \frac{F(\psi)}{R} \quad B_z = \frac{1}{R} \frac{\partial \psi}{\partial R}$$

4. The pressure profile can then be obtained from $p = p(\psi(R, z))$.

Application of solving Grad-Shafranov equation for designing a tokamak



- Given $I_{\text{plasma}}, p(\psi), I(\psi), I_{\text{coils}}$, free boundary of plasma, perfect conductor as the chamber.
- Given $I_{\text{plasma}}, p(\psi), I(\psi), I_{\text{coils}}$, free boundary of plasma, insulator chamber.
- Given $I_{\text{plasma}}, p(\psi), I(\psi), I_{\text{coils}}$, free boundary of plasma, chamber with eddy current.
- Given $I_{\text{plasma}}, p(\psi), I(\psi)$, fixed boundary of plasma. Then, use I_{coils} , free boundary of plasma and match the plasma shape calculated in the fixed boundary condition.

$$\Delta^* \psi = -\mu_0 R^2 \frac{dp}{d\psi} - \frac{1}{2} \frac{dF^2}{d\psi} \quad \text{where } \Delta^* \psi = R^2 \nabla \cdot \left(\frac{\nabla \psi}{R^2} \right)$$

$$j_\phi = R \frac{dp}{d\psi} + \frac{1}{2\mu_0 R} \frac{dF^2}{d\psi} \quad I_P = -2\pi F(\psi)$$

$$\mu_0 \vec{j} = \left(\frac{\nabla F}{R} \right) \times \hat{\phi} + \left(-\frac{1}{R} \Delta^* \psi \right) \hat{\phi} \quad \vec{B} = \left(\frac{\nabla \psi}{R} \right) \times \hat{\phi} + \frac{F(\psi)}{R} \hat{\phi}$$

Application of solving Grad-Shafranov equation for reconstructing a tokamak equilibrium state



- **Measure**
 - boundary conditions, including ψ , B , etc., on the wall (using flux loop and B-dot probe).
 - Pressure.
 - Plasma current (using Rogowski coil).
- Reconstruct $\psi(r,z)$, j , $p(\psi)$, $I(\psi)$, etc.

$$\Delta^* \psi = -\mu_0 R^2 \frac{dp}{d\psi} - \frac{1}{2} \frac{dF^2}{d\psi} \quad \text{where } \Delta^* \psi = R^2 \nabla \cdot \left(\frac{\nabla \psi}{R^2} \right)$$

$$I_p = -2\pi F(\psi)$$

$$\mu_0 \vec{j} = \left(\frac{\nabla F}{R} \right) \times \hat{\phi} + \left(-\frac{1}{R} \Delta^* \psi \right) \hat{\phi} \quad \vec{B} = \left(\frac{\nabla \psi}{R} \right) \times \hat{\phi} + \frac{F(\psi)}{R} \hat{\phi}$$

Example of the analytical solution of the Grad-Shafranov equation



$$\Delta^* \psi = -\mu_0 R^2 \frac{dp}{d\psi} - \frac{1}{2} \frac{dF^2}{d\psi}$$

• For $\mu_0 \frac{dp}{d\psi} = -C_2$ $\frac{1}{2} \frac{dF^2}{d\psi} = C_1$

$$\psi(R, z) = -\frac{C_1}{2} z^2 + \frac{C_2}{8} R^4 + C_3 + C_4 R^2 + C_5 (R^4 - 4R^2 z^2)$$

$$C_1 = 1$$

$$C_2 = -8$$

$$C_3 = -20$$

$$C_4 = 20$$

$$C_5 = 0.2$$

$$B_R(R, z) = -\frac{1}{R} (-C_1 z - 8C_5 R^2 z) \quad B_z(R, z) = \frac{1}{R} \left(\frac{C_2}{2} R^3 + 2C_4 R + C_5 (4R^3 - 8Rz^2) \right)$$

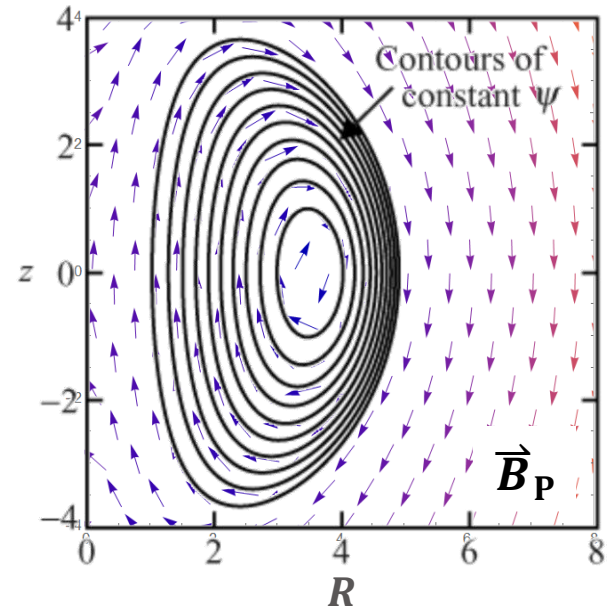
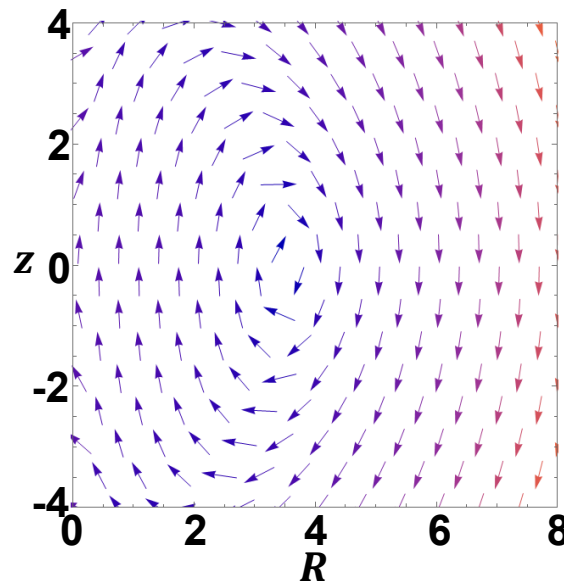
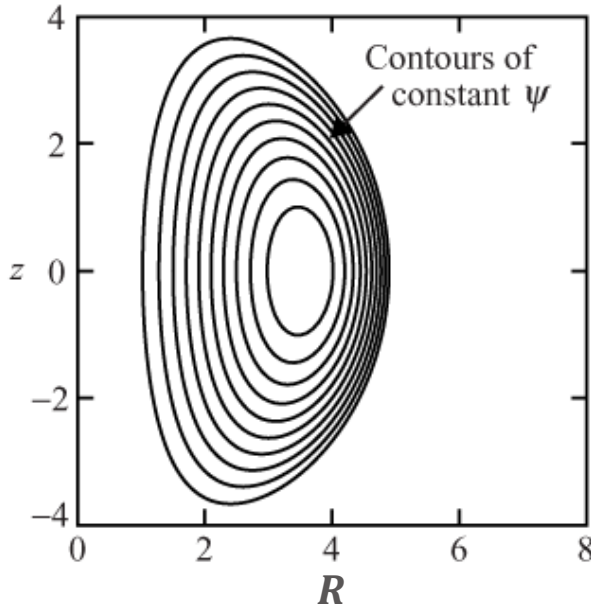

Examples: Large Aspect Ratio Tokamak



$$\Delta^* \psi = -\mu_0 R^2 \frac{dp}{d\psi} - \frac{1}{2} \frac{dF^2}{d\psi}$$

$$j_\phi = R \frac{dp}{d\psi} + \frac{1}{2\mu_0 R} \frac{dF^2}{d\psi}$$

• **Assuming:**

- $R_0 \gg a$
- $j_\phi = j_0 = \text{constant}$
- $F(\psi) = B_0 R_0 = \text{constant}$

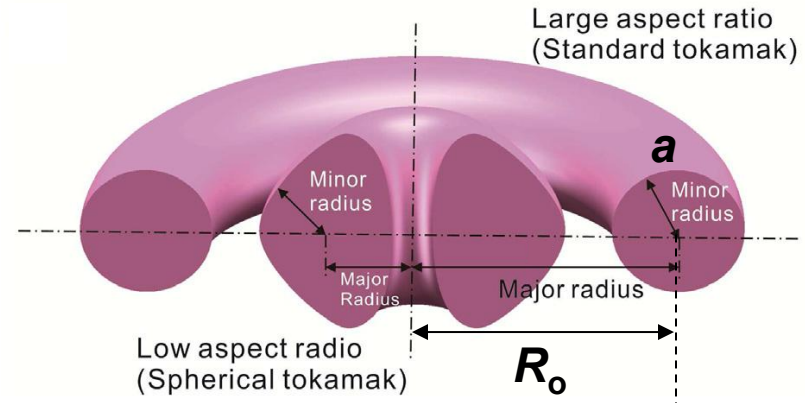

$$\Delta^* \psi = R^2 \nabla \cdot \left(\frac{\nabla \psi}{R^2} \right) = \frac{\partial^2 \psi}{\partial z^2} + R \frac{\partial}{\partial R} \left(\frac{1}{R} \frac{\partial \psi}{\partial R} \right)$$

$$\Rightarrow \frac{dp}{d\psi} = \text{const} \quad \mu_0 j_\phi = -\frac{1}{R} \Delta^* \psi \quad \Rightarrow \quad -\mu_0 R j_0 = \frac{\partial^2 \psi}{\partial z^2} + R \frac{\partial}{\partial R} \left(\frac{1}{R} \frac{\partial \psi}{\partial R} \right)$$

$$\psi(R, Z) = \frac{1}{2} A (R^2 - R_0^2) + \frac{1}{2} B Z^2$$

$$\Delta^* \psi = A + B = -\mu_0 R j_0$$

$$\text{Let } A = B \equiv -\frac{\mu_0 j_0}{2}$$

$$\psi(R, Z) = -\frac{\mu_0 j_0}{4} [(R^2 - R_0^2) + Z^2]$$

Equilibrium reconstruction



- **Magnetic Diagnostics (Essential for the Grad-Shafranov equation)**
 - **Magnetic flux loops: Measure poloidal flux ψ at different locations.**
 - **Poloidal field (PF) probes: Measure B_p .**
 - **Toroidal field (TF) coils: Provide information on B_ϕ .**
 - **Rogowski coils: Measure total plasma current I_p .**
 - **Hall probes: Measure local magnetic fields.**
- **Interferometry & Thomson Scattering - Provide electron density profile $n_e(r)$.**
- **X-ray & Spectroscopy - Measure soft X-ray emission, used to infer internal plasma profiles.**
- **Motional Stark Effect (MSE) & Polarimetry - Measure the pitch angle of the magnetic field, used to infer the safety factor profile $q(\psi)$.**
- **Soft X-ray and ECE Imaging - Can give additional constraints on plasma shape and profiles.**

Equilibrium reconstruction – conti.



$$\Delta^* \psi = -\mu_0 R^2 \frac{dp}{d\psi} - \frac{1}{2} \frac{dF^2}{d\psi} \quad j_\phi = R \frac{dp}{d\psi} + \frac{1}{2\mu_0 R} \frac{dF^2}{d\psi}$$

$j_\phi(\psi)$ $p(\psi)$ $F(\psi)$ **<= They are constrained with each other. When two are given, the third can be calculated.**

- **Adjustable functions: $F(\psi)$ and $p(\psi)$ are written in analytical forms.**
- **Solve Grad-Shafranov for $\psi(R,Z)$**
- **Compute derived quantities (flux loops, magnetic probes, pitch angles)**
- **Compare to diagnostics**
- **Adjust profile parameters**
- **Repeat until residuals are minimized**
- **Calculate $j_\phi(\psi)$**

Magnetically confined toroidal equilibrium



1. Radial pressure balance in the poloidal plan needs to be provided so that the pressure contours form closed nested surfaces. Both toroidal and poloidal fields can readily accomplish this task.
 2. The radially outward expansion force inherent in all toroidal geometries needs to be balanced without sacrificing stability.
- Forces associated with toroidal force balance are usually than those corresponding to radial pressure balance. However, they are more difficult to compensate.

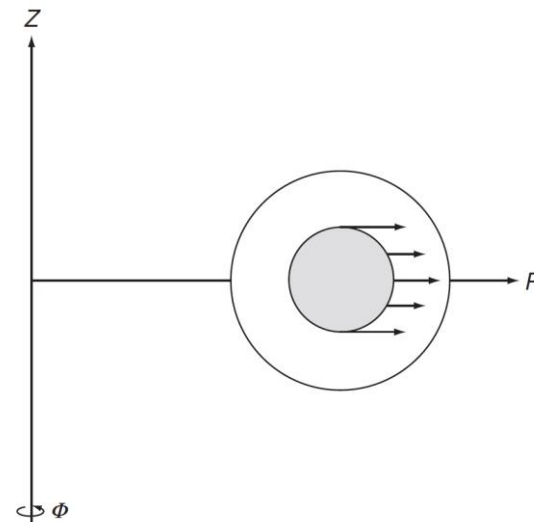
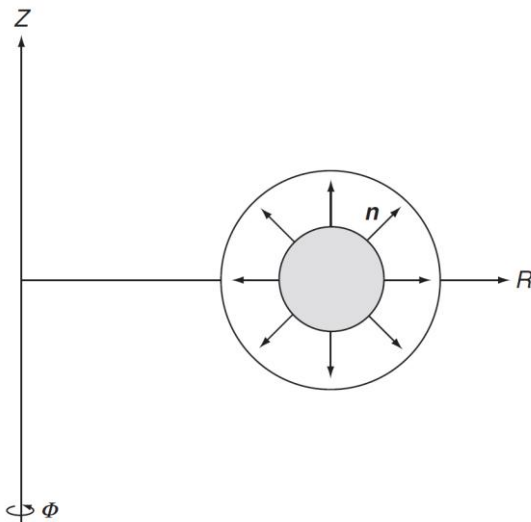

Toroidal configuration with a purely poloidal magnetic field



- Hoop force:

$$\psi_1 = \psi_2 \equiv \psi$$

$$S_1 < S_2 \quad B_1 > B_2$$

$$\vec{F}_{H,R} \propto \hat{e}_R \frac{B_1^2 S_1 - B_2^2 S_2}{2\mu_0} > 0$$

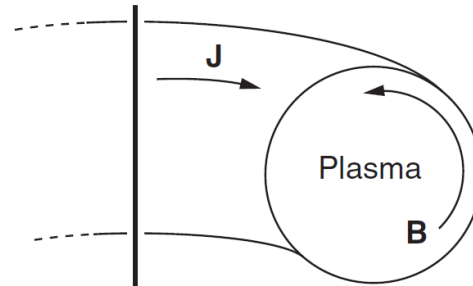
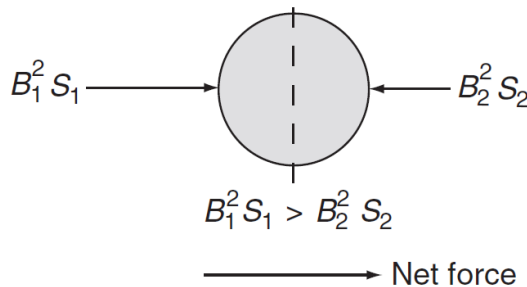
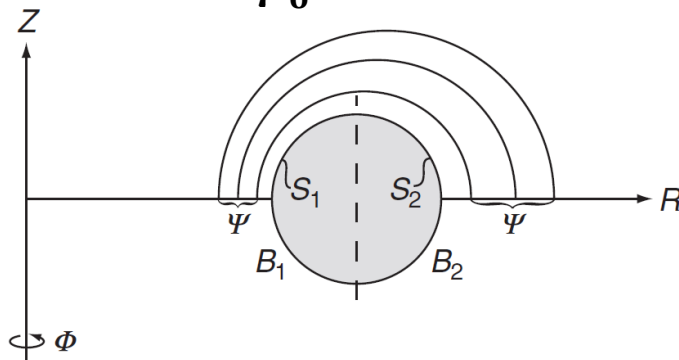

- Tire tube force

$$p_1 = p_2 \equiv p$$

$$S_1 < S_2$$

$$\vec{F}_{T,R} \propto -\hat{e}_R (pS_1 - pS_2) > 0$$

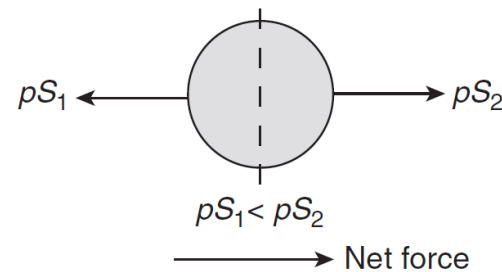
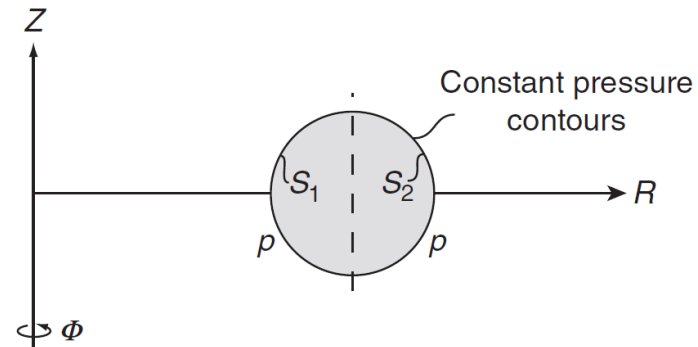

The outward force can be compensated by either a perfectly conducting shell or externally applied vertical field



- Perfectly conducting shell

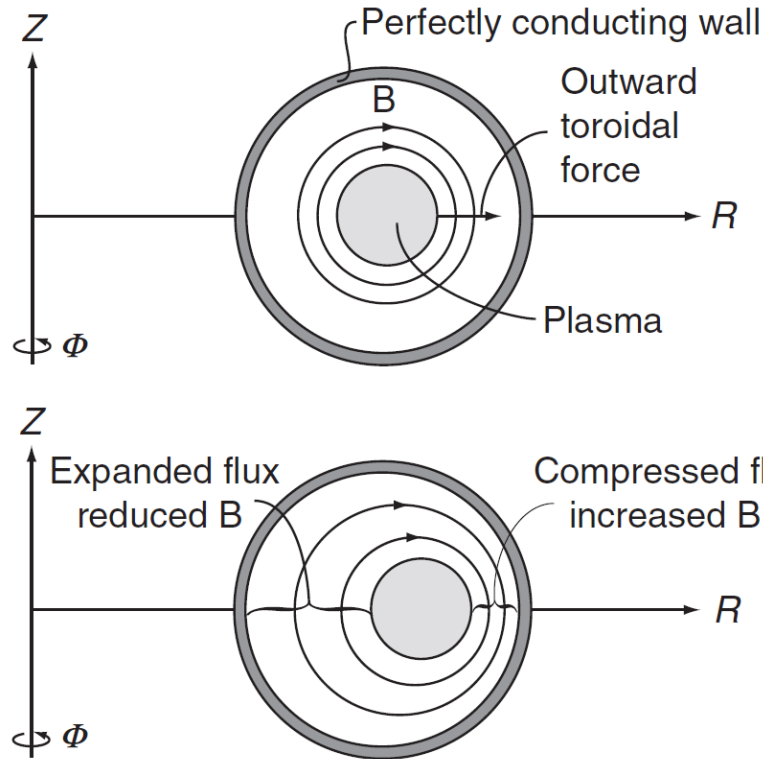

- Externally applied vertical field

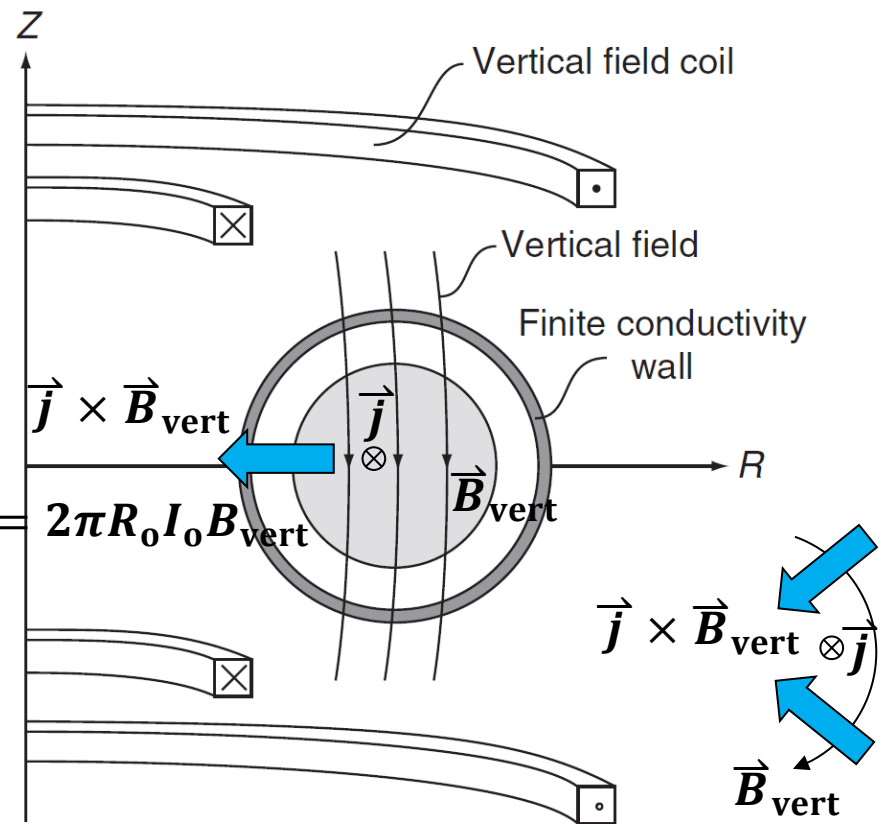

- With a finite conductivity wall, flux can only remain compressed for about a skin time.
- This configuration develops disastrous MHD instabilities (z pinch).

Toroidal configuration with a purely toroidal magnetic field, stable but NOT balanced

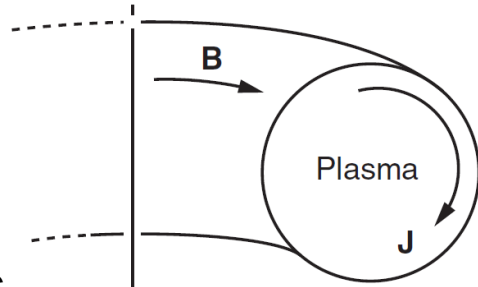

Plasma is diamagnetic

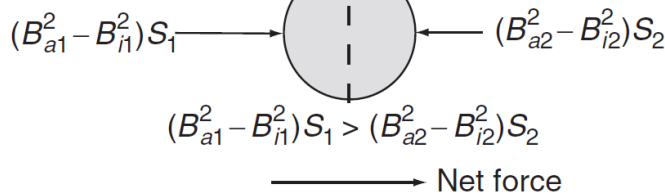
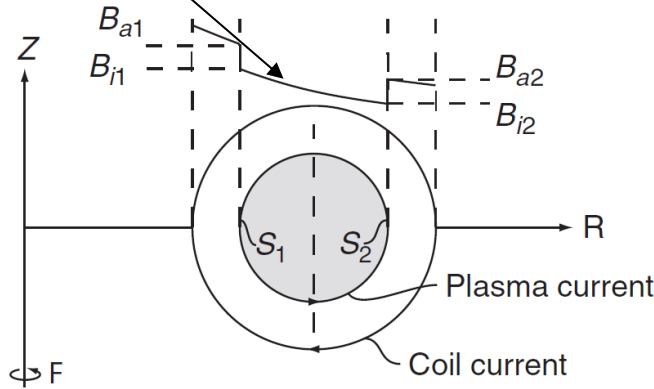

$$\vec{B} = B_\phi \hat{e}_\phi \quad B_\phi = B_0 \frac{R_0}{R} \quad B_0 = \frac{\mu_0 I_c}{2\pi R_0}$$

$$\vec{F}_R \propto \hat{e}_R \frac{(B_{a1}^2 - B_{i1}^2)S_1 - (B_{a2}^2 - B_{i2}^2)S_2}{2\mu_0} > 0$$

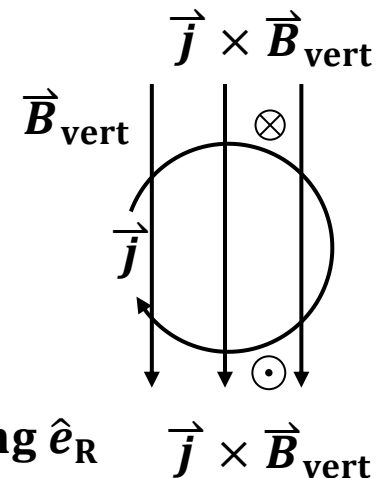
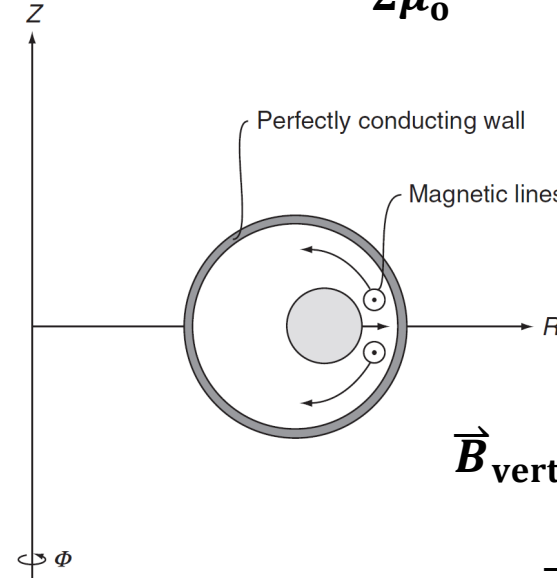

$$\vec{j} \times \vec{B}_{\text{vert}}$$

is not pointed along \hat{e}_R

$$\vec{j} \times \vec{B}_{\text{vert}}$$

Coils in a tokamak

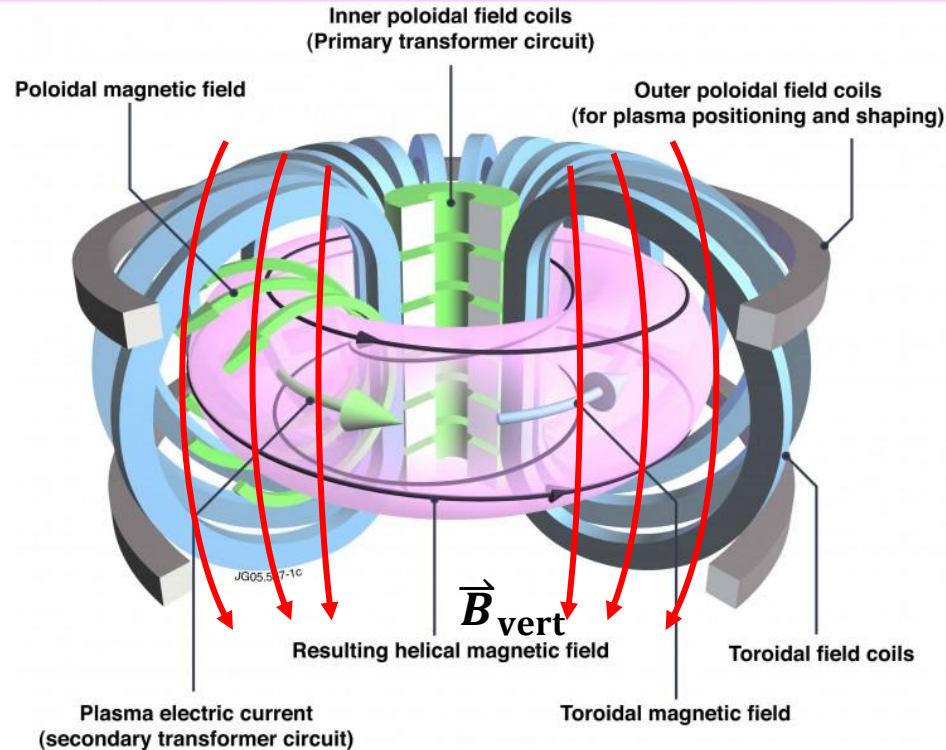

- Toroidal field coils (in poloidal direction) – generate toroidal field for confinement.
- Poloidal field coils – generate vertical field for plasma positioning and shaping.
- Central solenoid – for breakdown and generating plasma current (in toroidal direction) and thus generating poloidal field for confinement.

Fluxes and currents

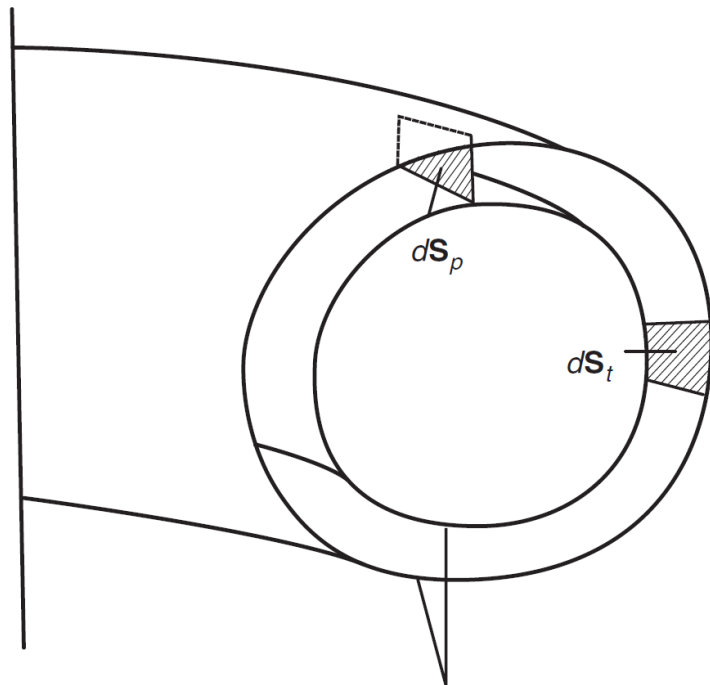

Two neighboring flux surfaces

- **Poloidal flux:** $\psi_p = \int \vec{B} \cdot d\vec{S}_p$
 $\psi_p = \psi_p(p)$
- **Toroidal flux:** $\psi_t = \int \vec{B} \cdot d\vec{S}_t$
- **Poloidal current:** $I_p = \int \vec{j} \cdot d\vec{S}_p$
- **Toroidal current:** $I_t = \int \vec{j} \cdot d\vec{S}_t$

Normalized plasma pressure, β



$$\beta = \frac{\text{plasma pressure}}{\text{magnetic pressure}} = \frac{2\mu_0 \langle p \rangle}{B^2}$$

- Plasma pressure: $\langle p \rangle = \frac{1}{V_p} \int p d\vec{r}$

- Magnetic pressure: $P_B = \frac{B^2}{2\mu_0}$

$$B^2 = B_t^2 + B_p^2 = B_0^2 + \left(\frac{\mu_0 I_p}{2\pi a}\right)^2 \frac{2}{1 + \kappa^2}$$

$$B_t^2 = B_0^2 \quad B_0 = B @ R = R_0$$

$$B_p^2 = \left(\frac{\mu_0 I_p}{2\pi a}\right)^2 = \left(\frac{\mu_0 I_p}{C_p}\right)^2$$

$$C_p \approx 2\pi a \sqrt{\frac{1 + \kappa^2}{2}}$$

$$\beta_t = \frac{2\mu_0 \langle p \rangle}{B_0^2} \quad \beta_p = \frac{4\pi^2 a^2 (1 + \kappa^2) p}{\mu_0 I_p^2}$$

$$\frac{1}{\beta} = \frac{1}{\beta_t} + \frac{1}{\beta_p}$$

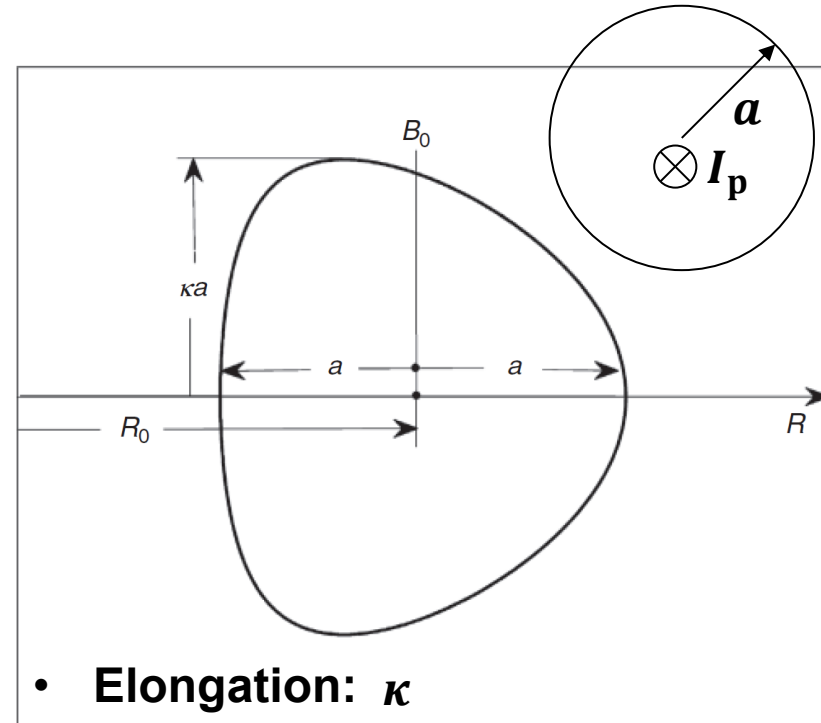

Different poloidal shapes

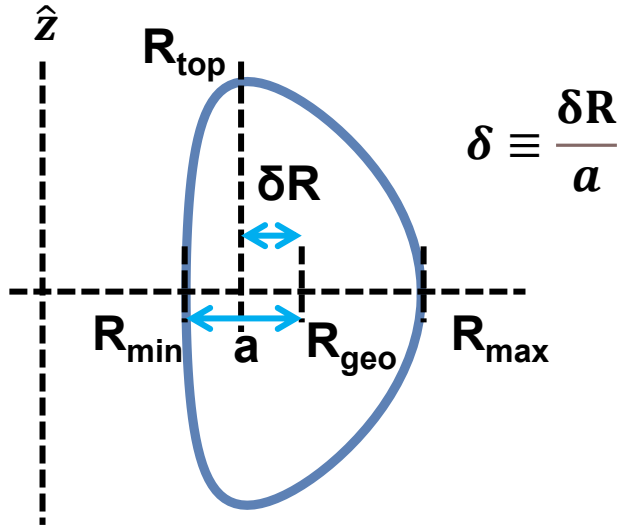

$$r = R + a \cos(\theta + \delta \sin(\theta))$$

$$z = a \kappa \sin(\theta)$$

- Aspect ratio: $\frac{R}{a}$
- Elongation: κ
- Triangularity: δ

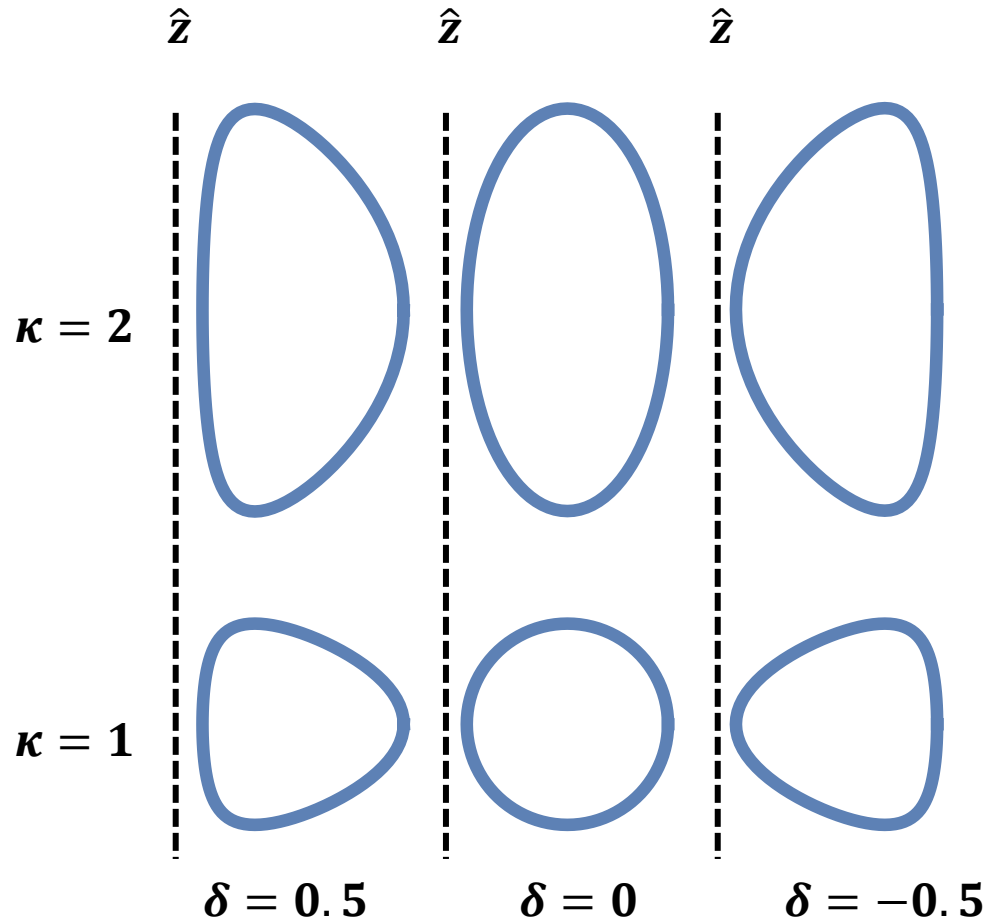

Safety factor



- Kink Safety Factor:

$$q^*(r) = \frac{aB_o}{R_oB_p} = \frac{2\pi a^2 \kappa B_o}{\mu_o R_o I_o}$$

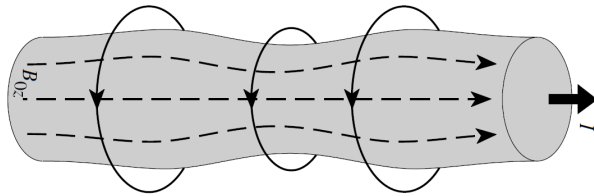

$$q(r) = \frac{rB_z(r)}{R_oB_\theta(r)}$$

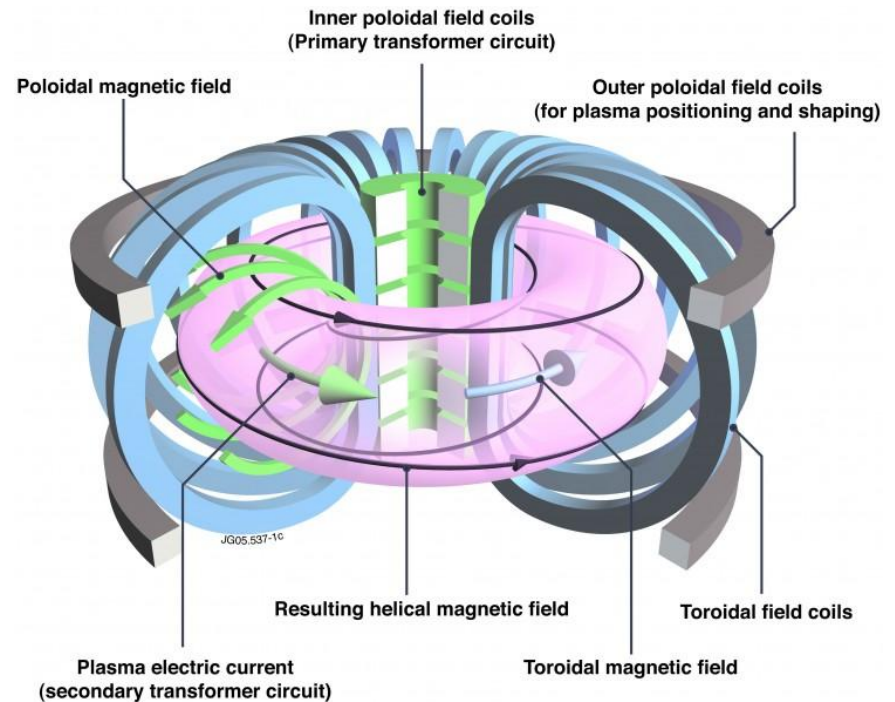

Kink instability in action in a 3 by 25-cm pyrex tube at Aldermaston

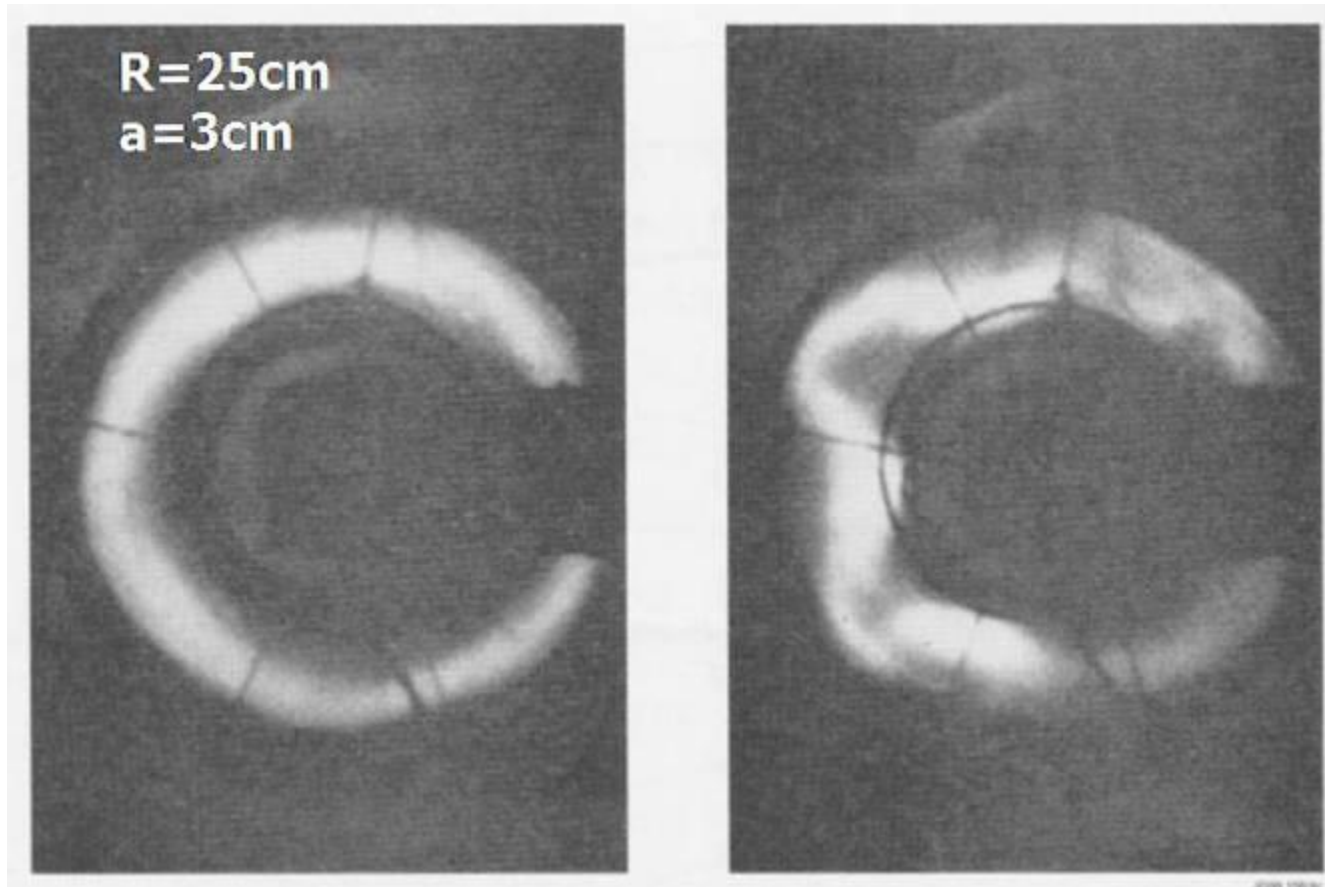

https://en.wikipedia.org/wiki/Kink_instability

R A Bingham et al 2026 Plasma Phys. Control. Fusion 68 030201

Safety factor

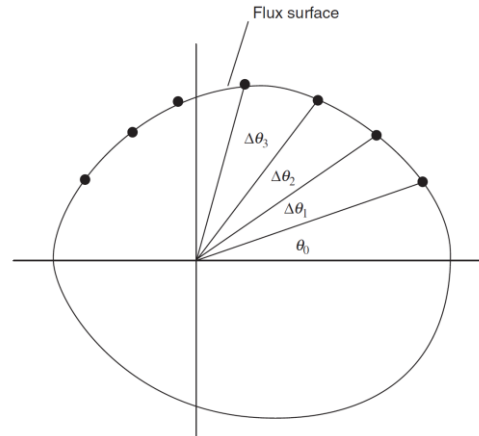
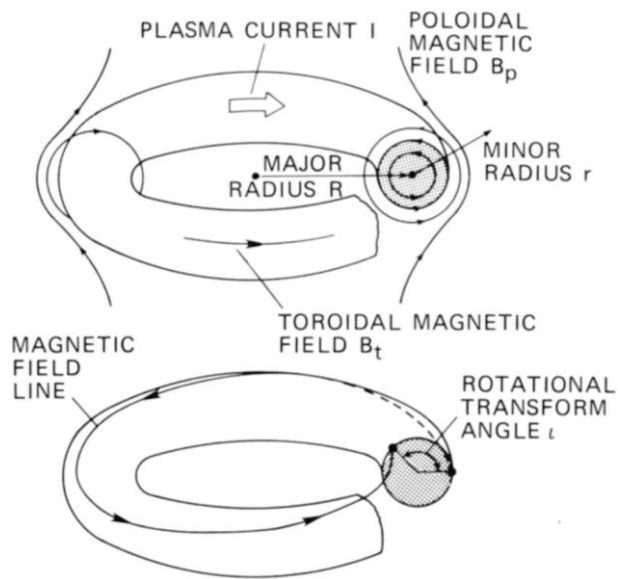

- **Shear:**

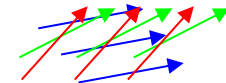
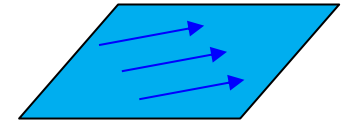
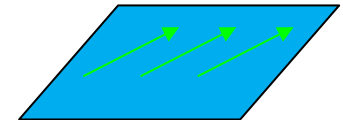
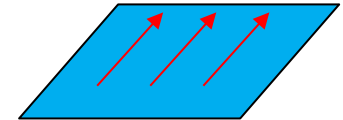

- **Rotational transform:**
$$\iota \equiv \lim_{N \rightarrow \infty} \frac{1}{N} \sum \Delta\theta_n$$
- **MHD safety factor:**
$$q(V) \equiv \frac{2\pi}{\iota(V)} = \frac{d\psi_t/dV}{d\psi_p/dV}$$
 $\psi_t = \psi_t(V) \quad \psi_p = \psi_p(V)$
- **Shear:**
$$s(V) \equiv 2 \frac{V}{q} \frac{dq}{dV}$$

$$\iota(V) \equiv 2\pi \left(\frac{d\psi_p/dV}{d\psi_t/dV} \right)$$

Global magnetic shear



- Shear

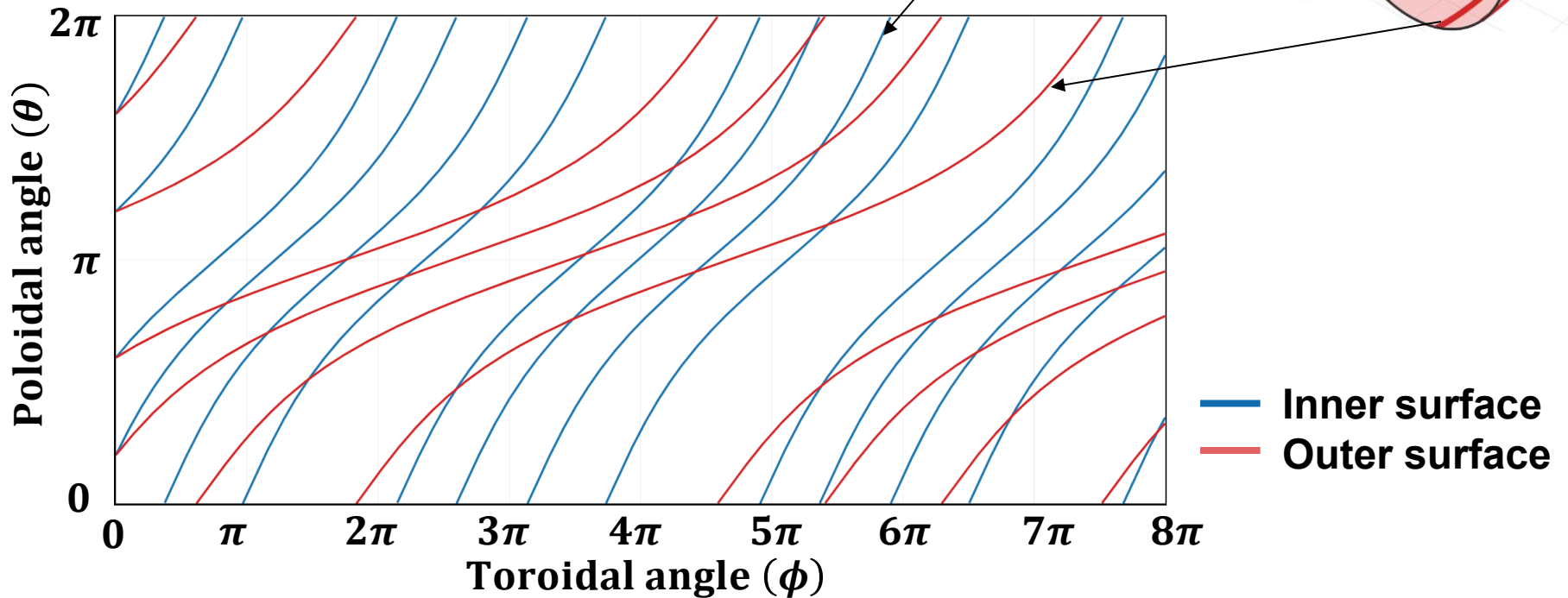
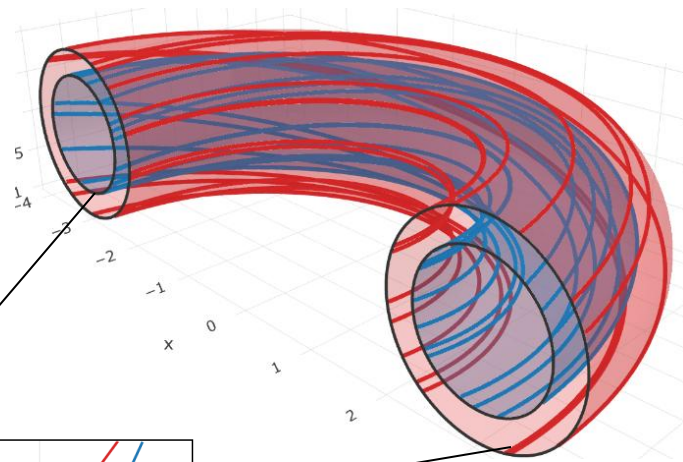
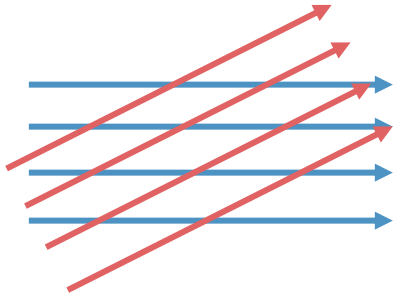

Volume of the constant flux

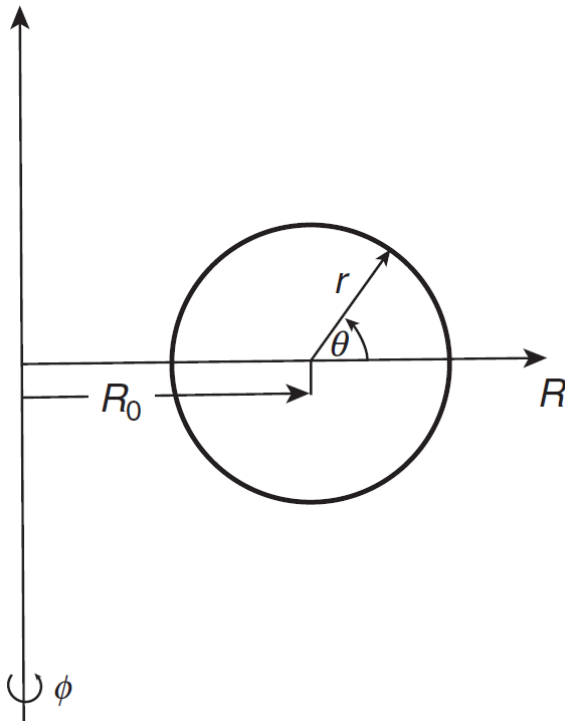

$$R = R_0 + r \cos \theta$$

$$Z = r \sin \theta$$

$$\psi = \psi(r, \theta)$$

$$r = \hat{r}(\theta, \psi)$$

$$V(\psi) = \int_0^{2\pi} \int_0^{2\pi} \int_0^{\hat{r}} R r dr d\theta d\phi$$

$$V(\psi) = \pi R_0 \int_0^{2\pi} d\theta \hat{r} \left[1 + \frac{2}{3} \left(\frac{\hat{r}}{R_0} \right) \cos \theta \right]$$

A cylindrical plasma column is stable when the safety factor is greater than unity



- Sausage instability ($m=0$)
- Kink instability

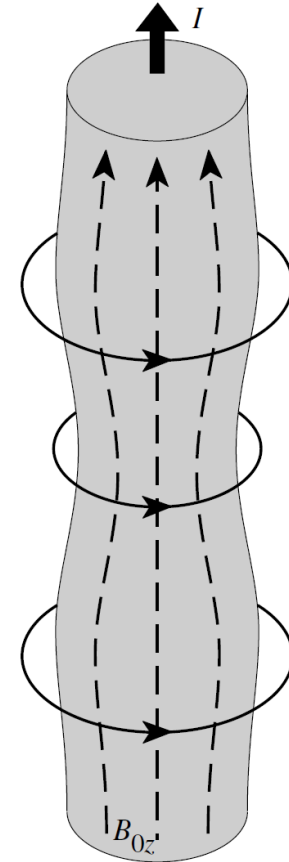
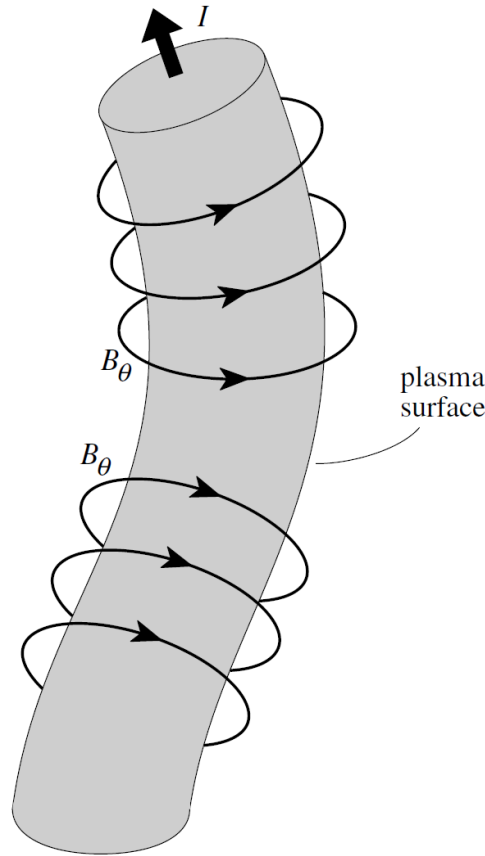
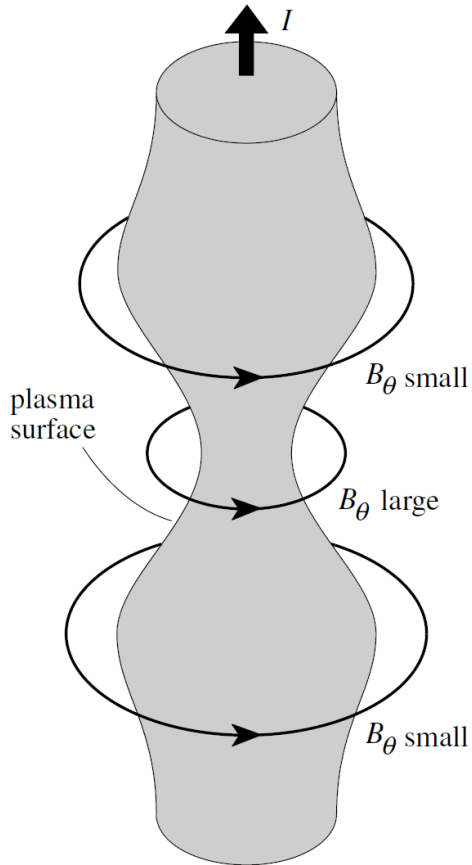

- MHD Safety factor: $q(r) = \frac{rB_z(r)}{R_0B_\theta(r)}$ Kruskal–Shafranov limit

Magnetic well



$$\widehat{W} = 2 \frac{V}{\langle B^2 \rangle} \frac{d}{dV} \left\langle \frac{B^2}{2} \right\rangle$$

$$= 2 \frac{V}{\langle B^2 \rangle} \frac{d}{dV} \left\langle \mu_0 p + \frac{B^2}{2} \right\rangle$$

- A magnetic well is a quantity that measures plasma stability against short perpendicular wavelength modes driven by the plasma pressure gradient.



A

NO EQUILIBRIUM



B

NEUTRALLY STABLE

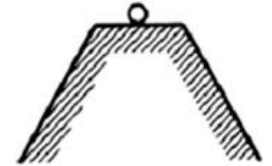

C

(METASTABLE) EQUILIBRIUM

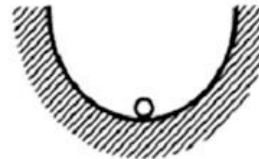

D

STABLE EQUILIBRIUM



E

UNSTABLE EQUILIBRIUM



F

EQUILIBRIUM WITH LINEAR STABILITY AND NONLINEAR INSTABILITY

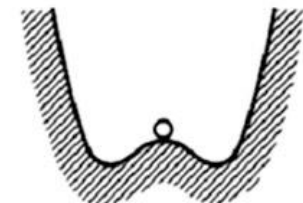

G

EQUILIBRIUM WITH LINEAR INSTABILITY AND NONLINEAR STABILITY

Variational formulation for checking stabilization



- **Equilibrium state:** $\vec{j}_o \times \vec{B}_o = \nabla p_o$
 - **Momentum eq:** $\rho_m \left[\frac{\partial \vec{v}}{\partial t} + (\vec{v} \cdot \nabla) \vec{v} \right] = \vec{j} \times \vec{B} - \nabla \cdot \vec{P}$
- $$\rho_m = \rho_o + \tilde{\rho}_1 \quad p = p_o + \tilde{p}_1 \quad \vec{v} = \vec{v}_o + \vec{v}_1 = \vec{v}_1 \equiv \frac{\partial \vec{\xi}}{\partial t}$$
- $$\vec{j} = \vec{j}_o + \vec{j}_1 \quad \vec{B} = \vec{B}_o + \vec{B}_1 \equiv \vec{B}_o + \vec{Q}$$

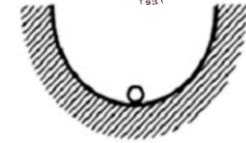

D

STABLE EQUILIBRIUM



E

UNSTABLE EQUILIBRIUM

$$\rho_m \frac{\partial^2 \vec{\xi}}{\partial t^2} = \vec{F}(\vec{\xi}) \quad \vec{F}(\vec{\xi}) = \vec{j}_o \times \vec{Q} + \vec{j}_1 \times \vec{B}_o - \nabla \tilde{p}_1$$

$$\vec{F}(\vec{\xi}) = \frac{1}{\mu_o} (\nabla \times \vec{B}_o) \times \vec{Q} + \frac{1}{\mu_o} (\nabla \times \vec{Q}) \times \vec{B}_o + \nabla (\vec{\xi} \cdot \nabla p + \gamma p \nabla \cdot \vec{\xi})$$

- **The change in potential energy associated with the perturbation:**

$$\delta W = -\frac{1}{2} \int \vec{\xi}^* \cdot \vec{F}(\vec{\xi}) d\vec{r} \quad \bullet \quad \text{Stable requirement: } \delta W \geq 0$$

$$\delta W_F = \frac{1}{2} \int d\vec{r} \left[\frac{|\vec{Q}_\perp|^2}{\mu_o} + \frac{B^2}{\mu_o} |\nabla \cdot \vec{\xi}_\perp + 2 \vec{\xi}_\perp \cdot \vec{\kappa}|^2 + \gamma p |\nabla \cdot \vec{\xi}|^2 \right. \\ \left. - 2(\vec{\xi}_\perp \cdot \nabla p) (\vec{\kappa} \cdot \vec{\xi}_\perp^*) - J_\parallel (\vec{\xi}_\perp^* \times \vec{b}) \cdot \vec{Q}_\perp \right]$$

Variational formulation for checking stabilization

- The change in potential energy associated with the perturbation:

$$\delta W = -\frac{1}{2} \int \vec{\xi}^* \cdot \vec{F}(\vec{\xi}) d\vec{r} \quad \bullet \text{ Stable requirement: } \delta W \geq 0$$

$$\delta W_F = \frac{1}{2} \int d\vec{r} \left[\frac{|\vec{Q}_\perp|^2}{\mu_0} + \frac{B^2}{\mu_0} |\nabla \cdot \vec{\xi}_\perp + 2 \vec{\xi}_\perp \cdot \vec{\kappa}|^2 + \gamma p |\nabla \cdot \vec{\xi}|^2 - 2(\vec{\xi}_\perp \cdot \nabla p)(\vec{\kappa} \cdot \vec{\xi}_\perp^*) - J_\parallel (\vec{\xi}_\perp^* \times \vec{b}) \cdot \vec{Q}_\perp \right]$$

- Stabilization terms:

$$\frac{|\vec{Q}_\perp|^2}{\mu_0}: \text{ For bending magnetic field lines, (shear Alfvén wave).}$$

$$\frac{B^2}{\mu_0} (|\nabla \cdot \vec{\xi}_\perp + 2 \vec{\xi}_\perp \cdot \vec{\kappa}|)^2: \text{ For compressing the magnetic field, (compressional Alfvén wave).}$$

$$\gamma p |\nabla \cdot \vec{\xi}|^2: \text{ For compressing the plasma, (sound wave).}$$

- Destabilization terms: $-2(\vec{\xi}_\perp \cdot \nabla p)(\vec{\kappa} \cdot \vec{\xi}_\perp^*) - J_\parallel (\vec{\xi}_\perp^* \times \vec{b}) \cdot \vec{Q}_\perp$

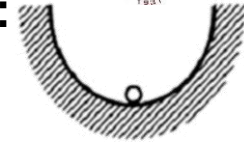

D

STABLE EQUILIBRIUM



E

UNSTABLE EQUILIBRIUM

Alfvén waves



- **Shear Alfvén wave:**

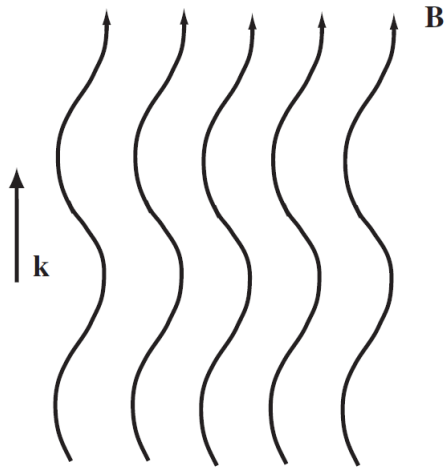

- **Longitudinal sound wave
(the slow magnetosonic wave)**

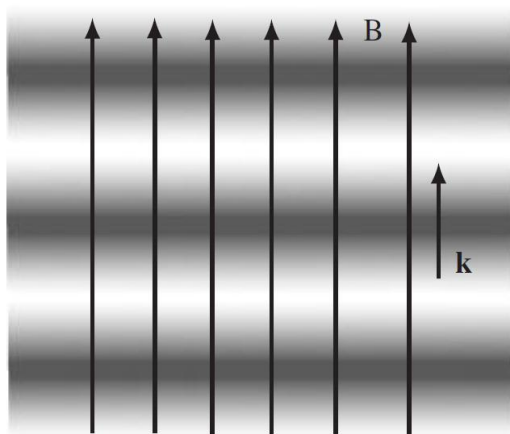

- **The fast magnetosonic wave
(Compressional Alfvén wave):**

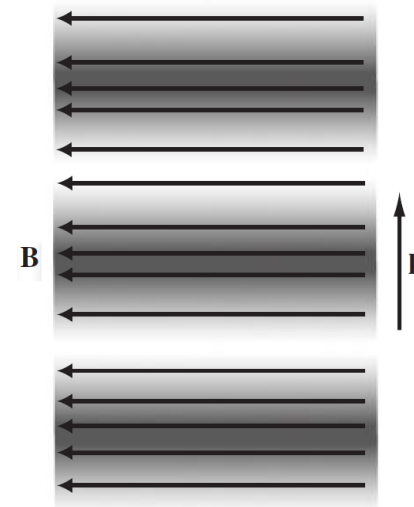

Alfvén waves



- Shear Alfvén wave:**

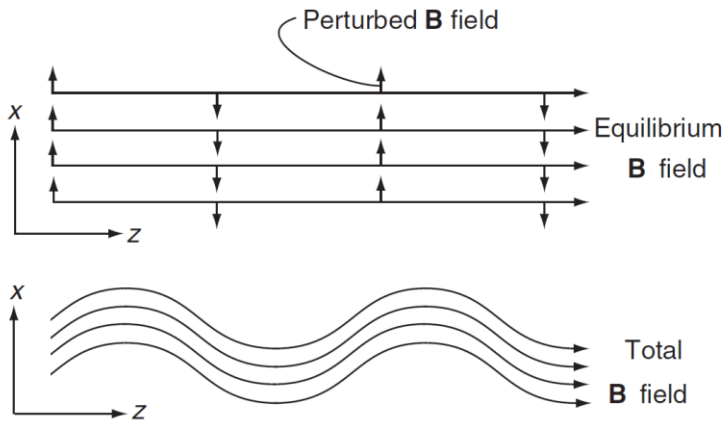

- The slow magnetosonic wave (Shear + Compressional Alfvén wave):**

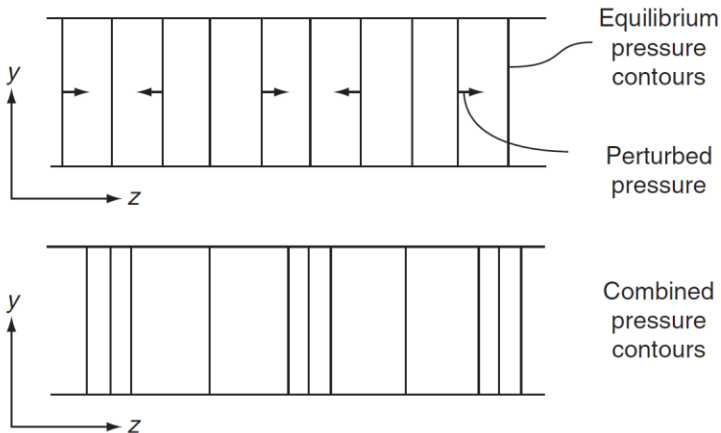

- The fast magnetosonic wave (Compressional Alfvén wave):**

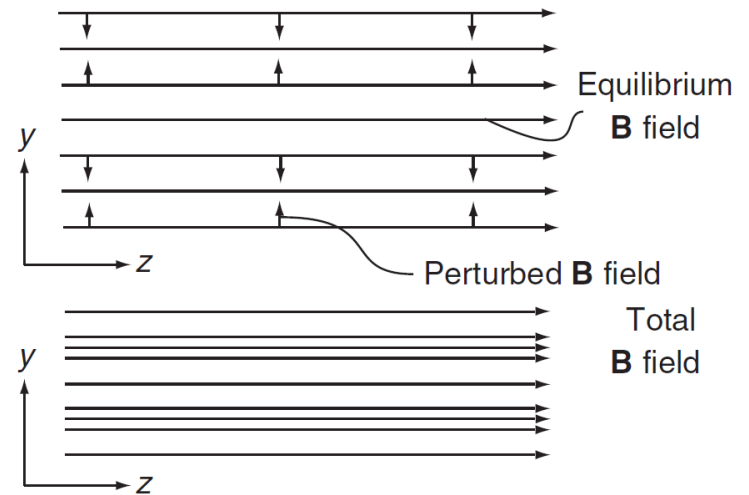

Classification of MHD instabilities



- **Locations:**
 - **Internal/Fixed boundary modes:** mode structure does not require any motion of the plasma-vacuum interface away from its equilibrium position.
 - **External/Free-boundary modes:** the plasma-vacuum interface moves from its equilibrium position during an unstable MHD perturbation.
- **Dominant destabilizing term**
 - **Pressure-driven modes:** the dominant destabilizing term is the one proportional to ∇p .
 - **Current-driven modes:** the dominant destabilizing term is the one proportional to J_{\parallel} .

$$\delta W_F = \frac{1}{2} \int d\vec{r} \left[\frac{|\vec{Q}_{\perp}|^2}{\mu_0} + \frac{B^2}{\mu_0} |\nabla \cdot \vec{\xi}_{\perp} + 2 \vec{\xi}_{\perp} \cdot \vec{\kappa}|^2 + \gamma p |\nabla \cdot \vec{\xi}|^2 - 2(\vec{\xi}_{\perp} \cdot \nabla p) (\vec{\kappa} \cdot \vec{\xi}_{\perp}^*) - J_{\parallel} (\vec{\xi}_{\perp}^* \times \vec{b}) \cdot \vec{Q}_{\perp} \right]$$

Classification of MHD instabilities



- **Locations:**
 - **Internal/Fixed boundary modes:** mode structure does not require any motion of the plasma-vacuum interface away from its equilibrium position.
 - **External/Free-boundary modes:** the plasma-vacuum interface moves from its equilibrium position during an unstable MHD perturbation.
- **Dominant destabilizing term**
 - **Current-driven modes, e.g., kink instability, sausage instability.**
 - **Pressure-driven modes, e.g., interchange mode, ballooning mode.**

External mode vs internal mode



- Predicted behaviors of the plasma in ITER

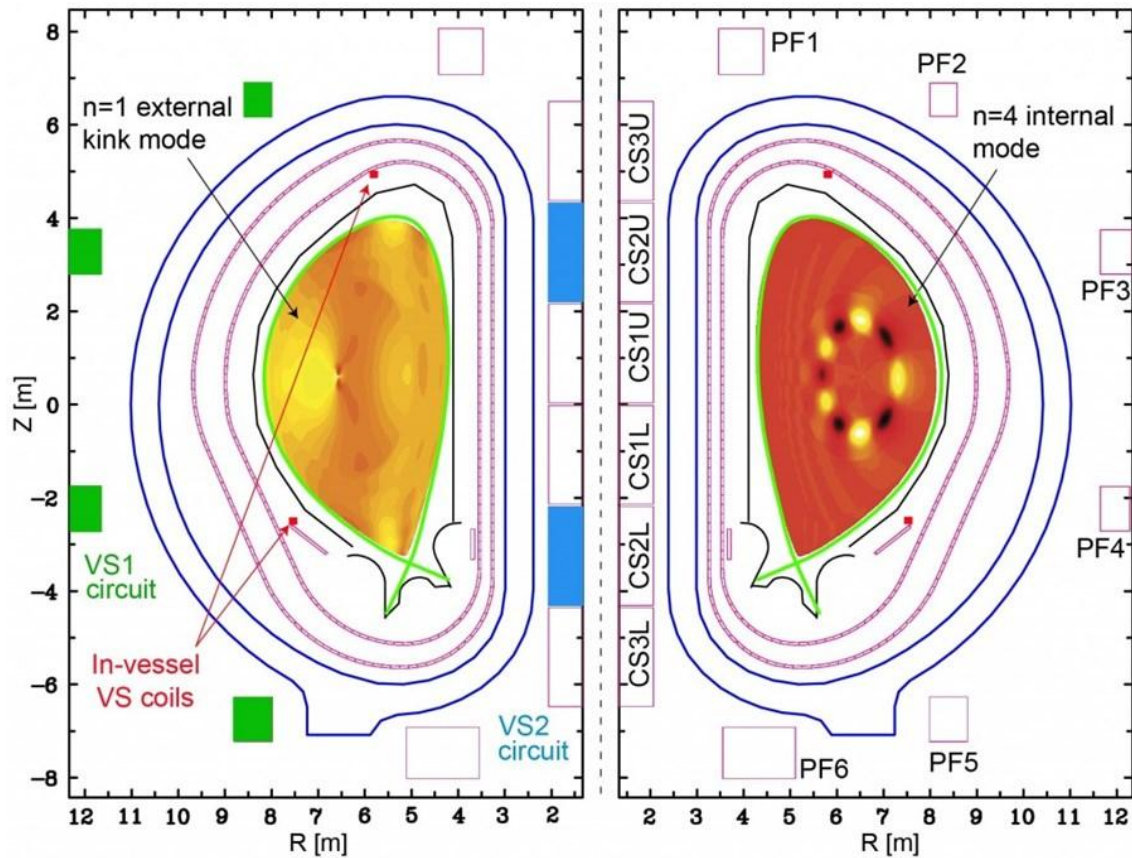

External vs internal kink instability



- External kink instability

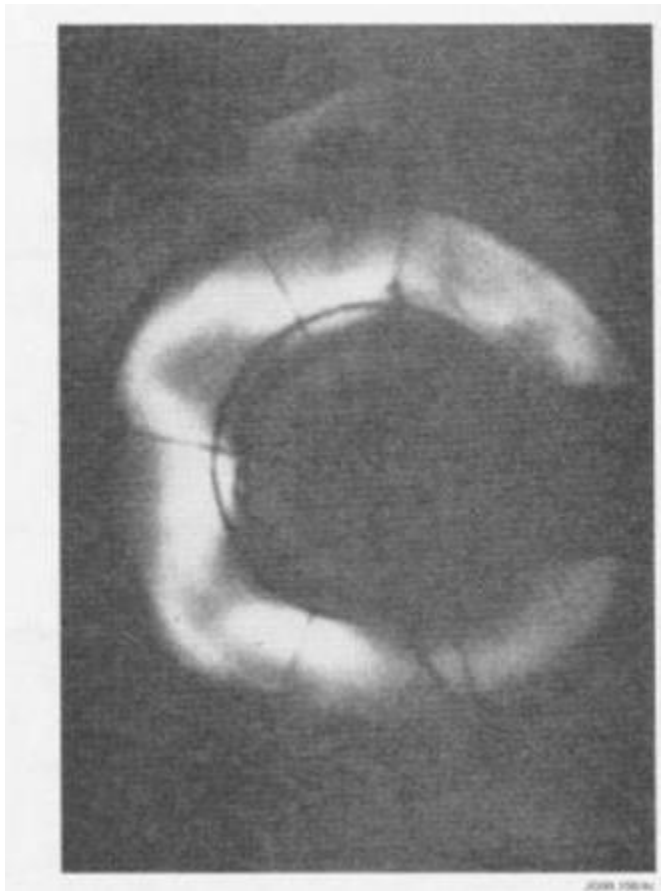

- Internal kink instability

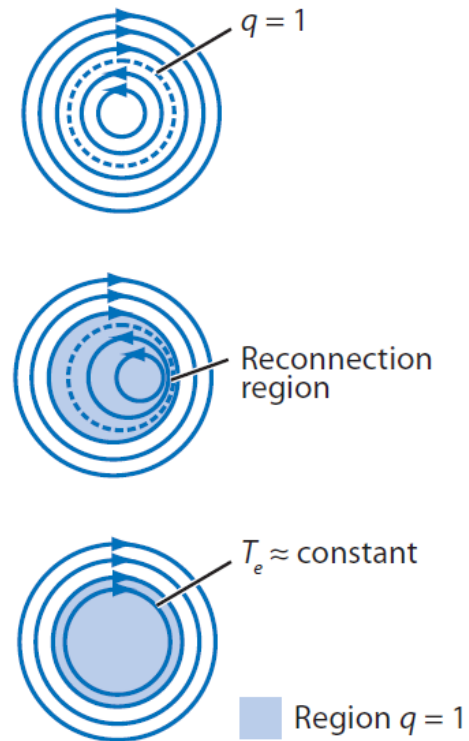

https://en.wikipedia.org/wiki/Kink_instability

R A Bingham et al 2026 Plasma Phys. Control. Fusion 68 030201

E. G. Zweibel and M. Yamada, Annu. Rev. Astron. Astrophys., 47, 291 (2009)

Current-driven instability



- Sausage instability ($m=0$)

- Kink instability ($m=1$)

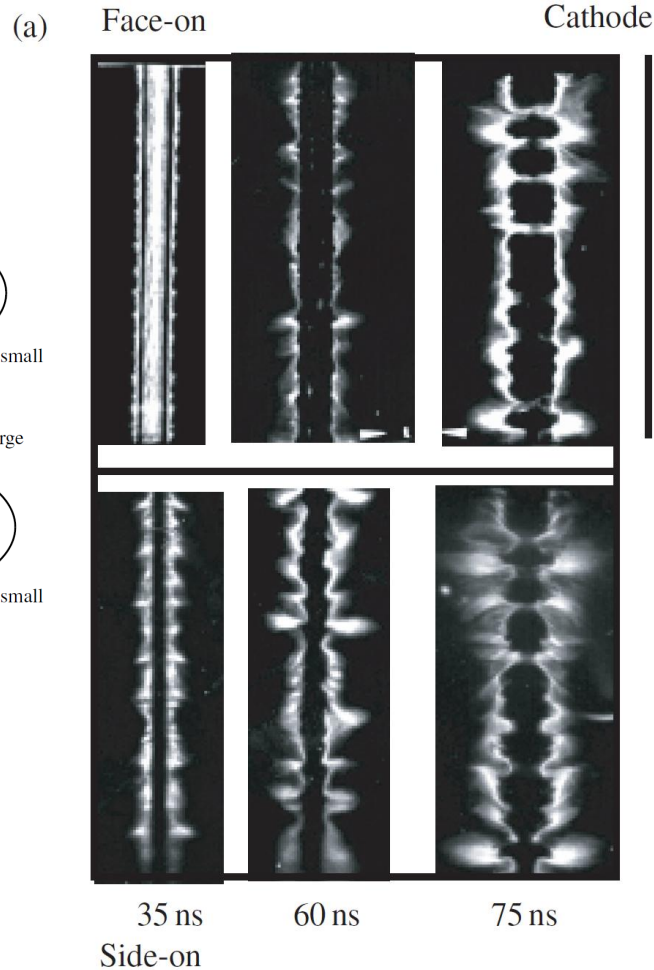

8.3 mm

54 ns 70 ns

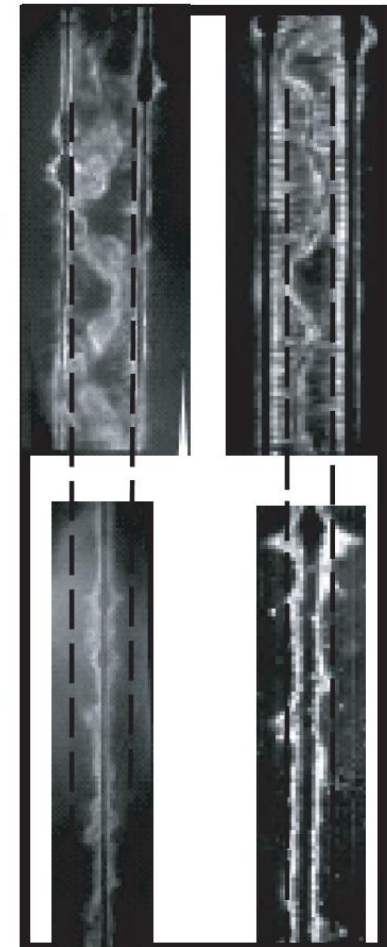

8.3 mm

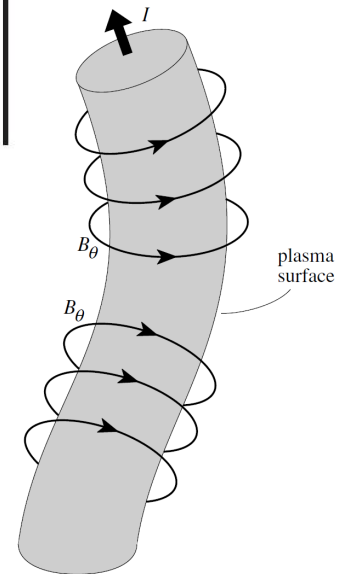

Kink instabilities in the lab

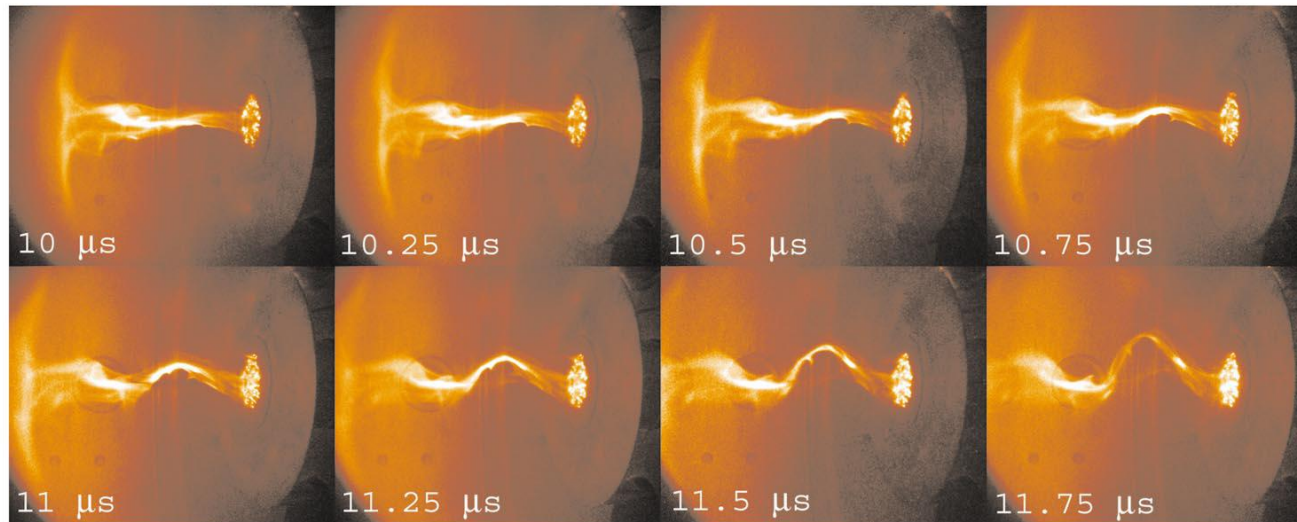
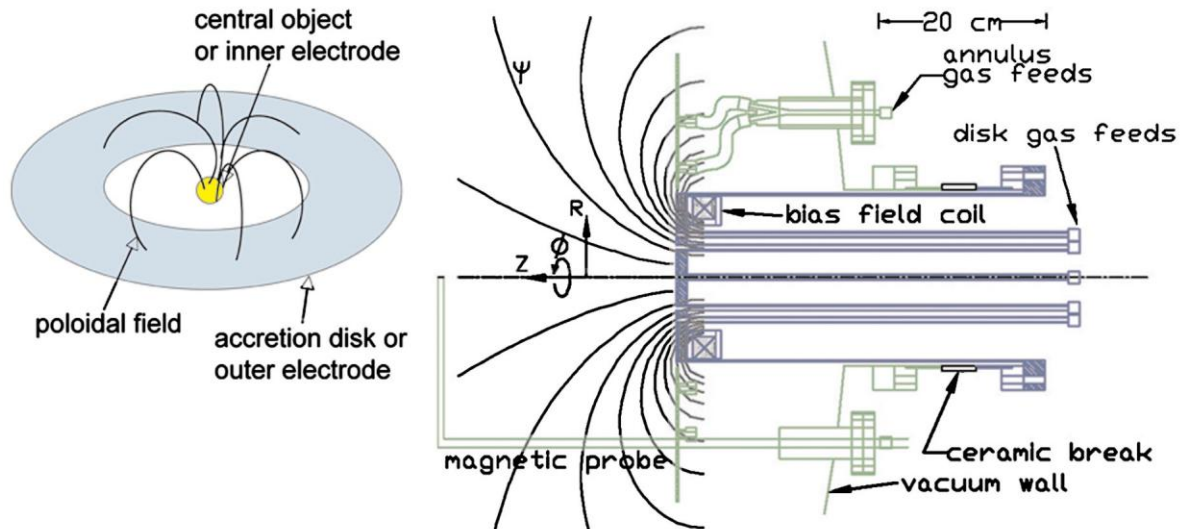

Kink instabilities in space

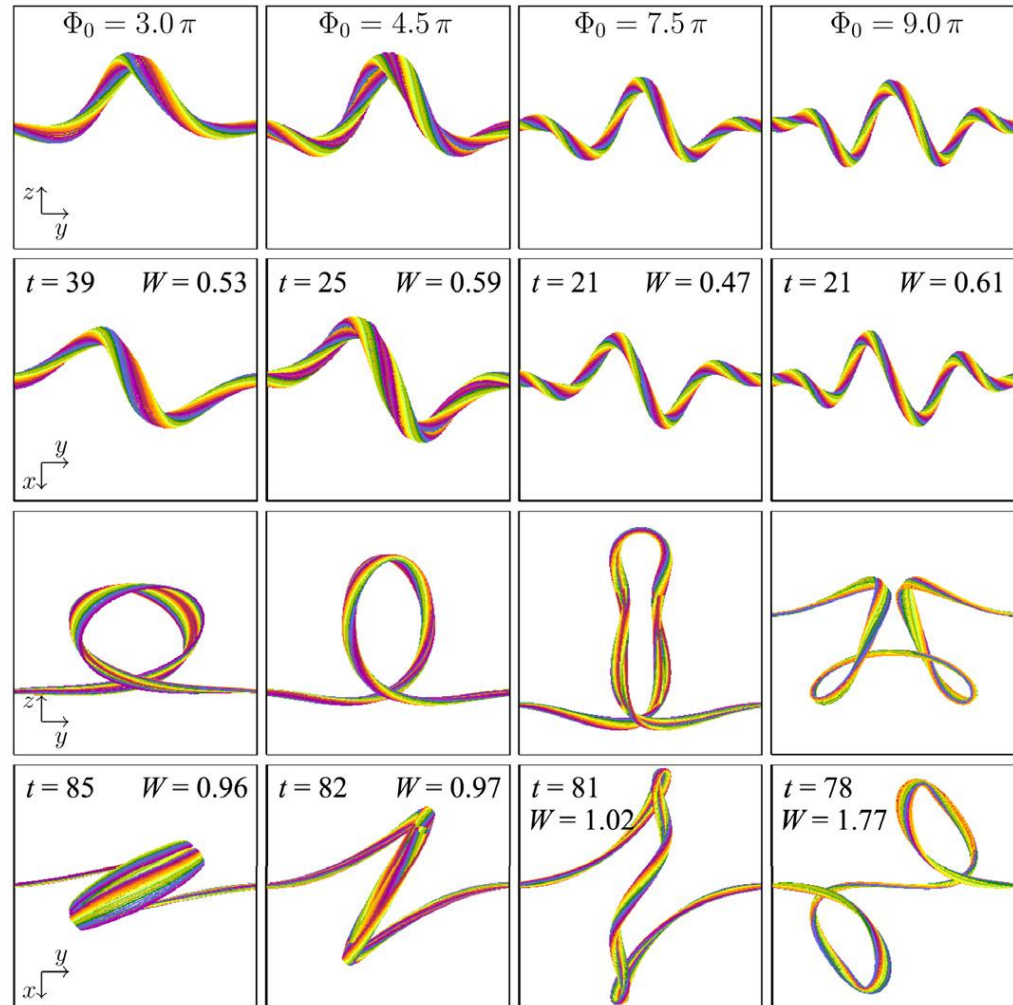
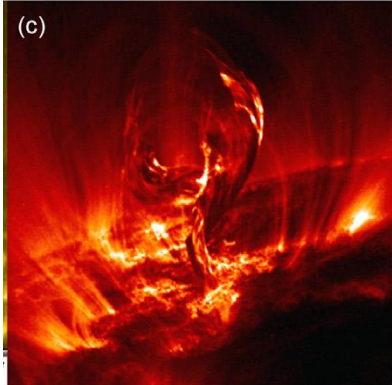
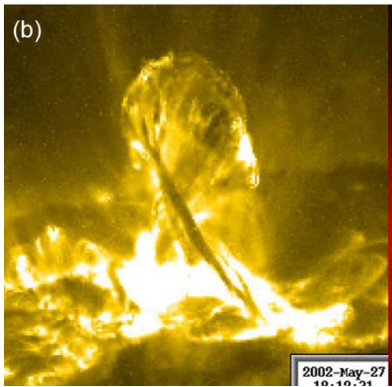
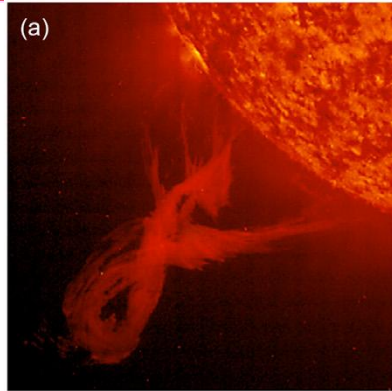

Kink instability in Tokamak

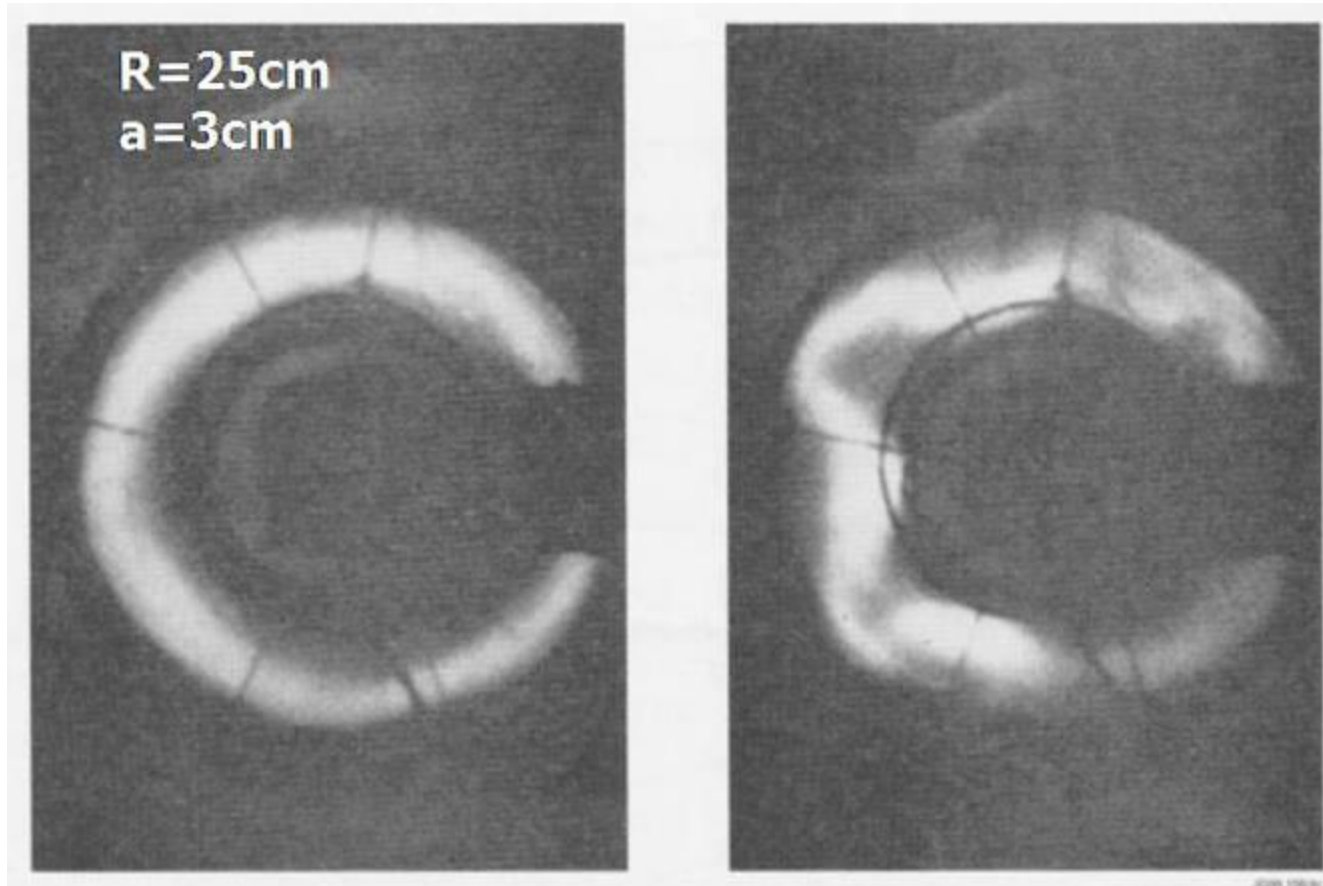

Pressure driven instability – interchange perturbations



- Unstable: bad curvature $\vec{R}_c \cdot \nabla p < 0$
- stable: good curvature $\vec{R}_c \cdot \nabla p > 0$

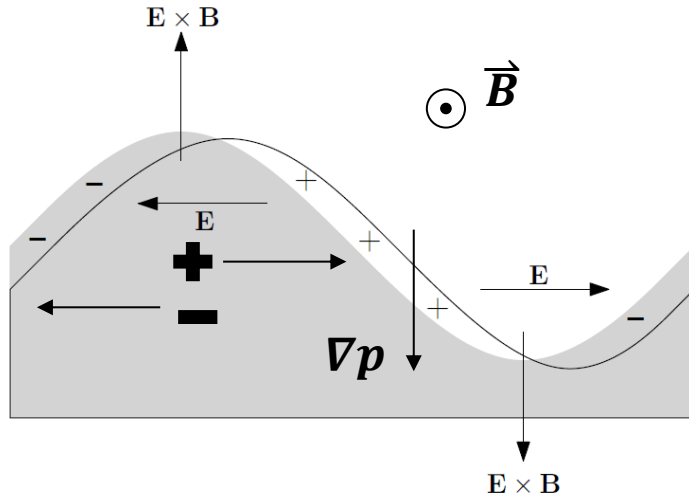

Unstable
plasma–vacuum
interface

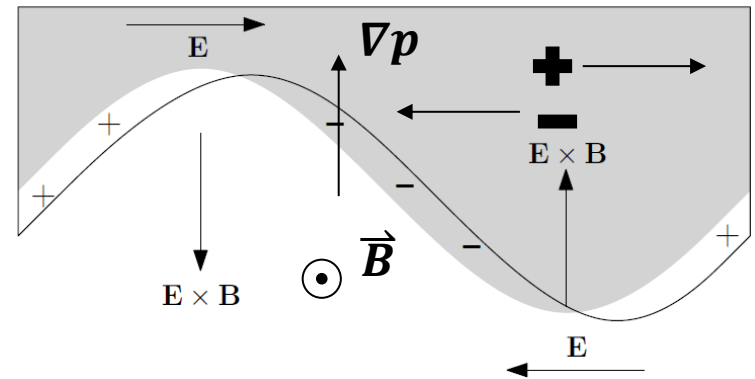
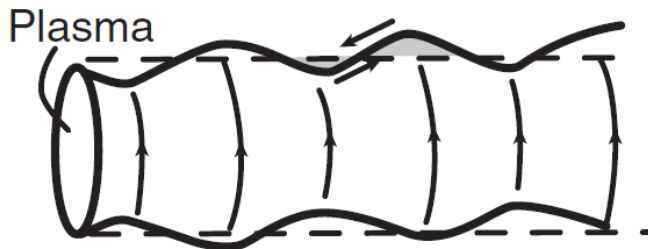

\vec{R}_c Curvature
 $\vec{R}_c \times \vec{B}$ Curvature drift

Stable
plasma–vacuum
interface

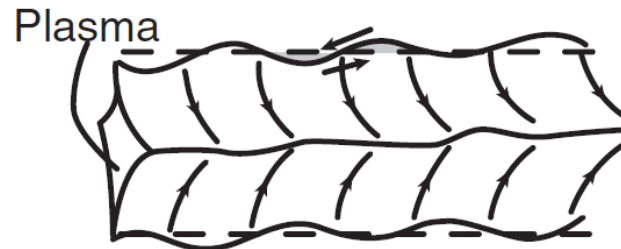

Rayleigh-Taylor instability



- Rayleigh-Taylor instability

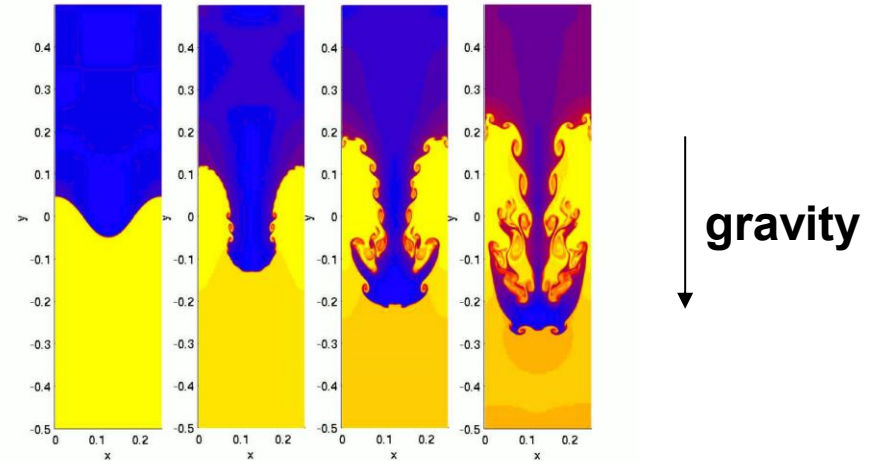
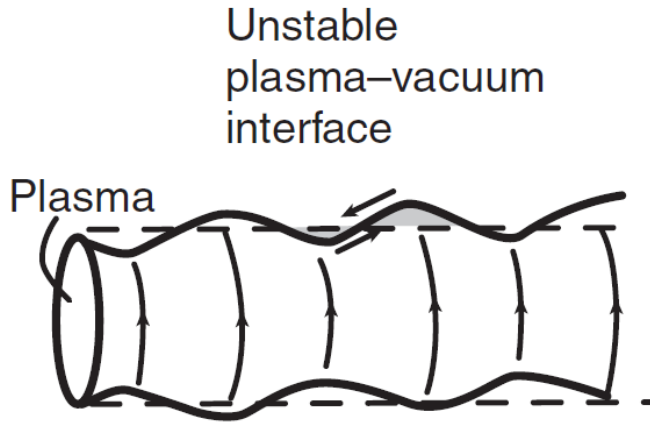

- Kelvin-Helmholtz instability

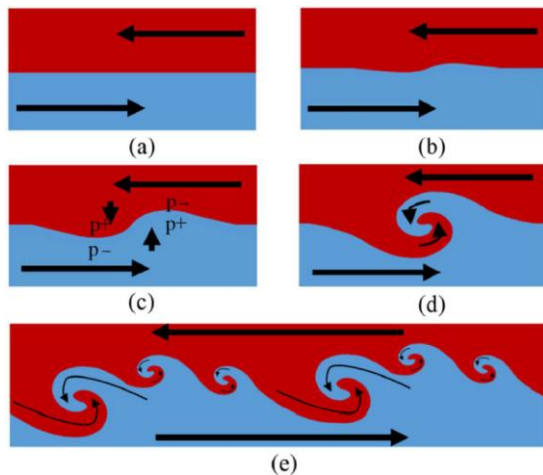

https://en.wikipedia.org/wiki/Rayleigh%E2%80%93Taylor_instability
https://en.wikipedia.org/wiki/Kelvin%E2%80%93Helmholtz_instability
 Xie Lei et al, Energy Report 7, 2262 (2021)

Pressure driven instability – interchange perturbations

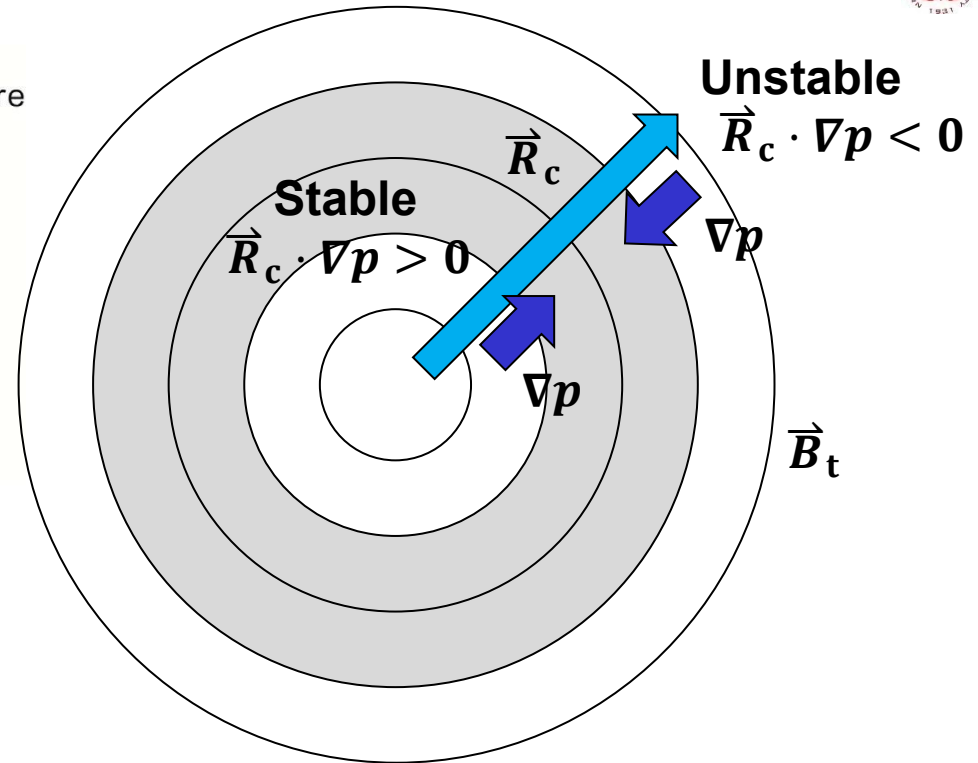
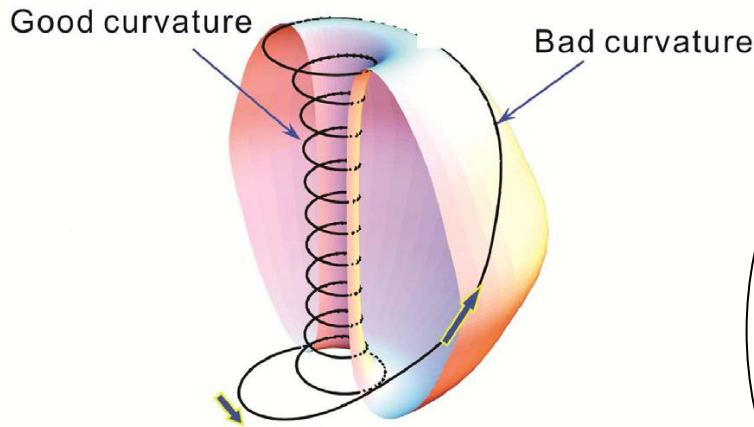

- Suydam criterion for cylindrical plasmas:

$$\mu_0 \frac{2r^2}{B_\theta^2} \frac{1}{s^2} \vec{R}_c \cdot \nabla p > -\frac{1}{4} \quad \text{Shear: } s = \frac{r}{q} \frac{dq}{dr}$$

- Mercier criterion for tokamak:

$$D = -\mu_0 \frac{2r}{B^2} \frac{1}{s^2} \frac{dp}{dr} (1 - q^2) < \frac{1}{4}$$

Ballooning mode – show wavelength mode



$$\delta W_F = \frac{1}{2} \int d\vec{r} \left[\frac{|\vec{Q}_\perp|^2}{\mu_o} + \frac{B^2}{\mu_o} |\nabla \cdot \vec{\xi}_\perp + 2 \vec{\xi}_\perp \cdot \vec{\kappa}|^2 + \gamma p |\nabla \cdot \vec{\xi}|^2 - 2(\vec{\xi}_\perp \cdot \nabla p)(\vec{\kappa} \cdot \vec{\xi}_\perp^*) - J_\parallel (\vec{\xi}_\perp^* \times \vec{b}) \cdot \vec{Q}_\perp \right]$$

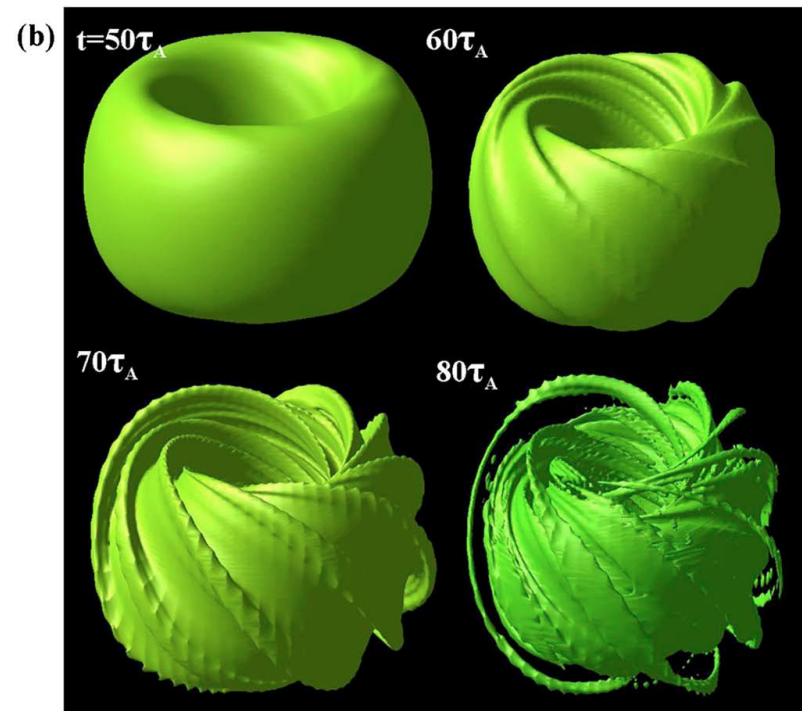
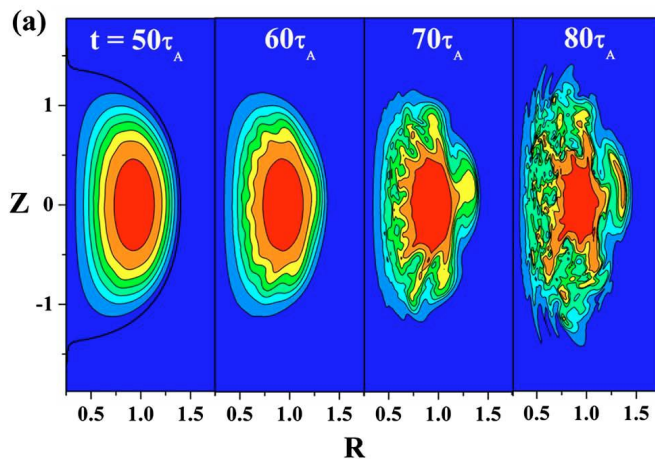
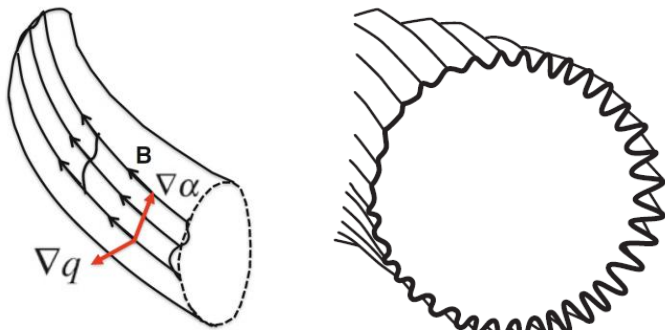

Ballooning mode – show wavelength mode



Tokamak Ballooning Mode Visualization (Artificial)
($m=5, n=4$) ($m=10, n=8$) ($m=15, n=12$)

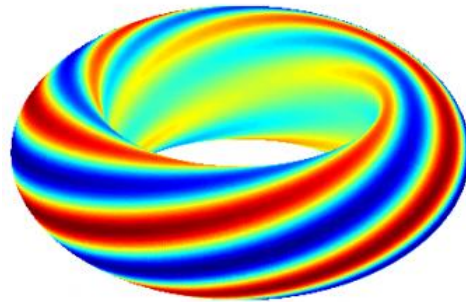

($m=5, n=4$)

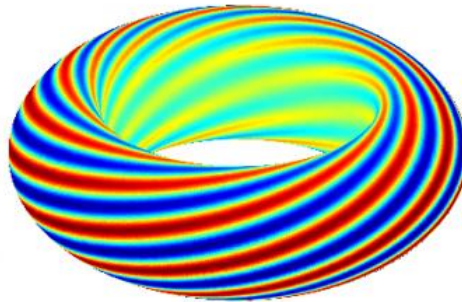

($m=10, n=8$)

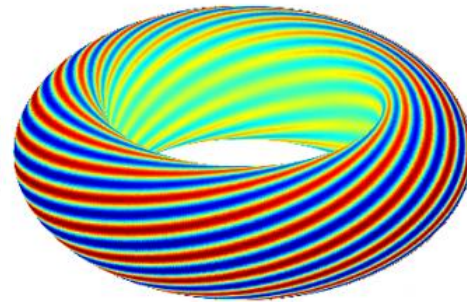

($m=15, n=12$)

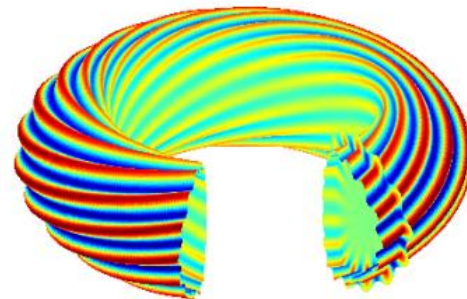
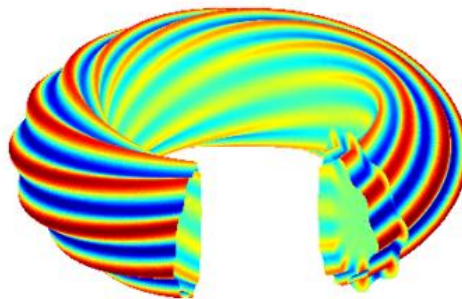
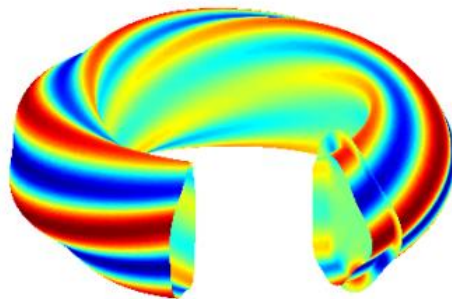

The Spherical tokamak



- Aspect ratio $R_0/a \sim 1.6$

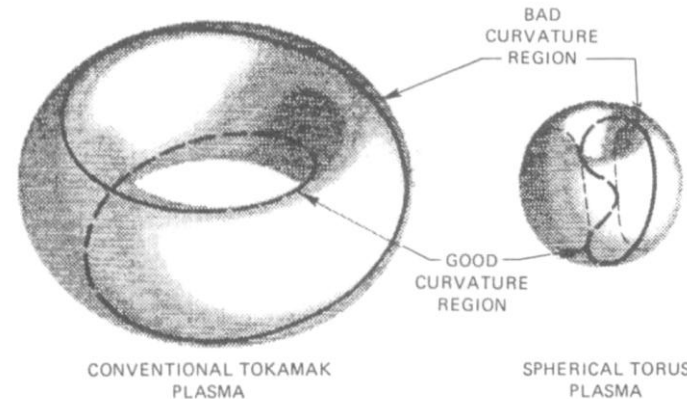
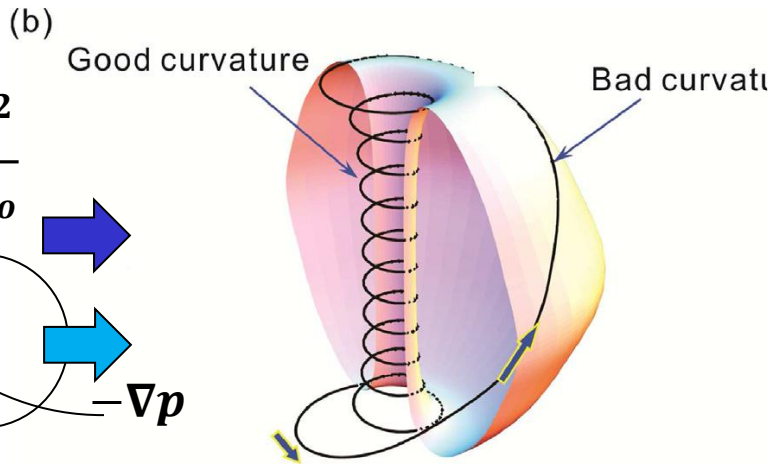
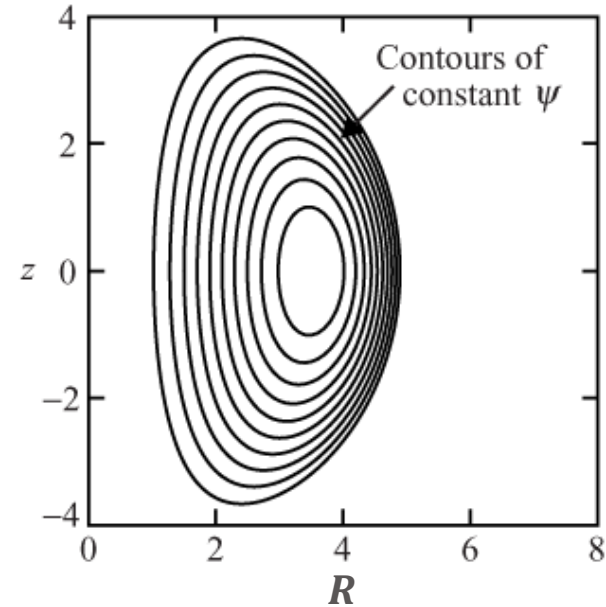
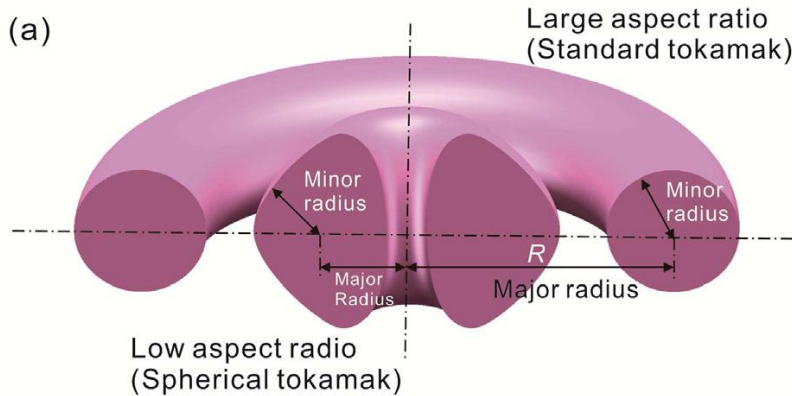

Zhe Gao, Matter and Radia. Extrem., **1**, 153 (2016)
 Y-k. M.Peng and D. J. Strickler, Nucl. Fusion **26**, 769 (1986)

The Spherical tokamak



- **Aspect ratio $R_0/a \sim 1.6$**
- **Advantages:**
 - **Higher β_t limit.**
 - **A compact design almost spherical in appearance.**
- **Challenges:**
 - **Minimum space is given in the center of the torus to accommodate the toroidal field coils.**
 - **With a very compact design the technology associated with the construction and maintenance of the device may be more difficult than for a “normal” tokamak.**
 - **Large currents will have to be driven noninductively, a costly and physically difficult requirement.**

Limiter protects the vacuum chamber from plasma bombardment and defines the edge of the plasma

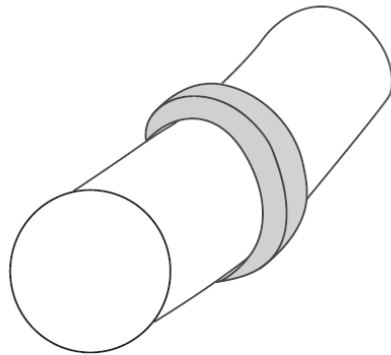

Poloidal limiter

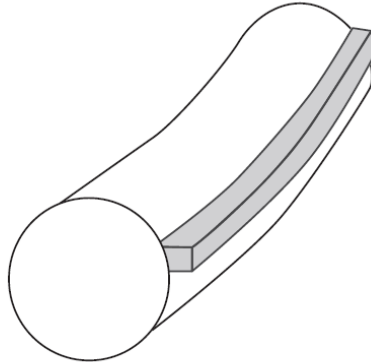

Toroidal limiter

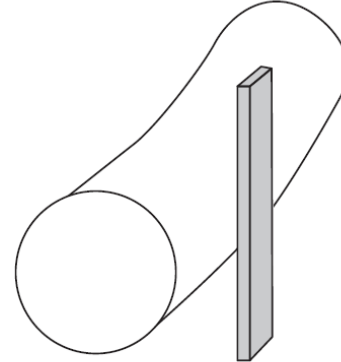

Rail limiter

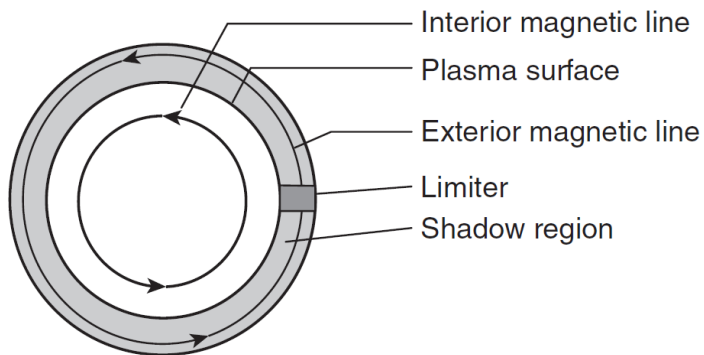

- **Vertical field is correct.**

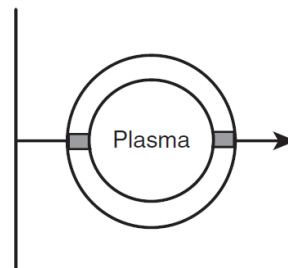

- **Vertical field is too small.**

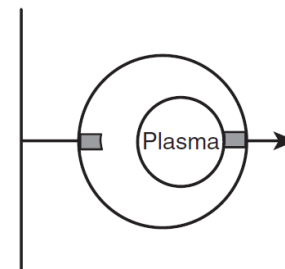

- **Vertical field is too large.**

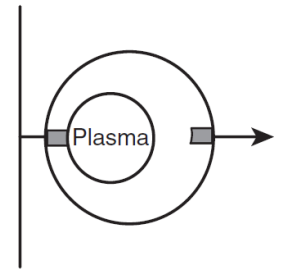

Limiter protects the vacuum chamber from plasma bombardment and defines the edge of the plasma



- A mechanical limiter is a robust piece of material, often made of tungsten, molybdenum, or graphite placed inside the vacuum chamber.
- Some of the particles of the limiter surface may escape. Neutral particles can penetrate some distance into the plasma before being ionized.
- The high-z impurities can lead to significant additional energy loss in the plasma through radiation.
- In ignition experiments and fusion reactors, the bombardment is more intense and extends over longer periods of time. In addition, if the impurity level is too high, it may not be possible to achieve a high enough temperature to ignite.

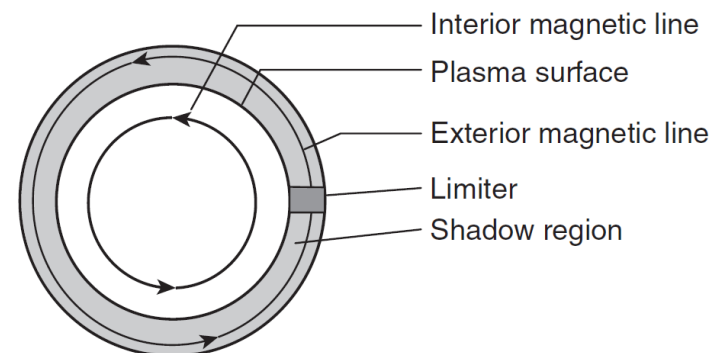

The magnetic divertor – guide a narrower layer of magnetic lines away from the edge of the plasma

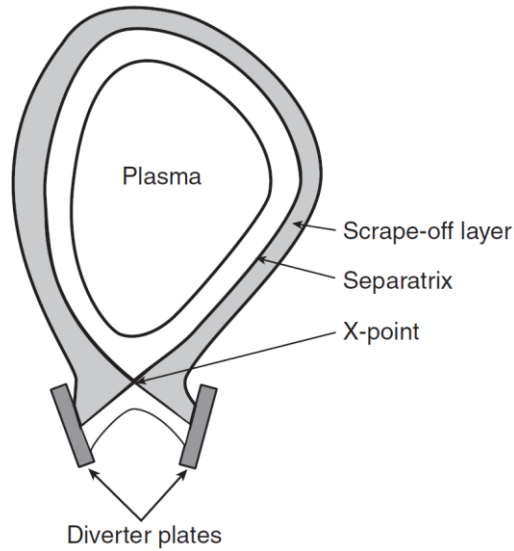

- **Single-null poloidal-field divertors for tokamak**

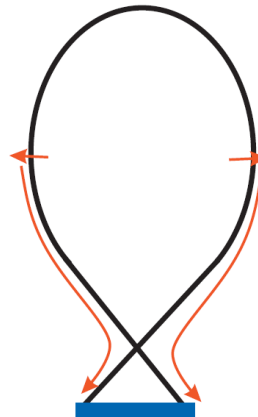

- **Double-null poloidal-field divertors for tokamak**

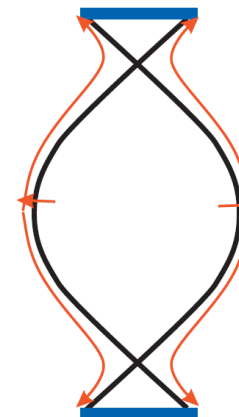

- **Island divertor for stellerators**

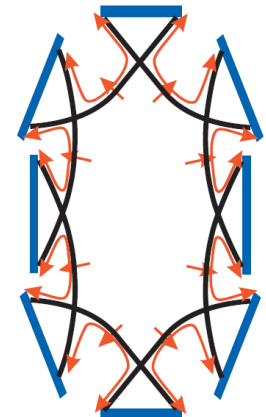

- **Standard**

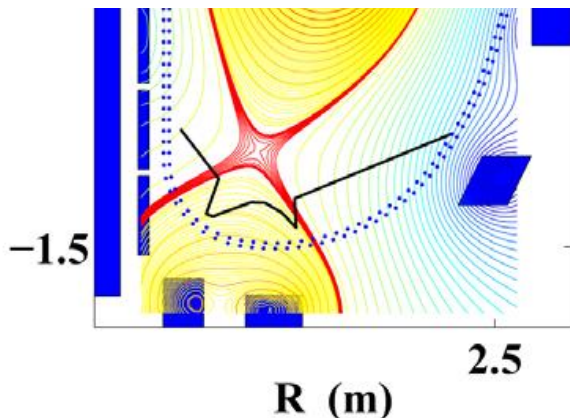

- **Snowflake**

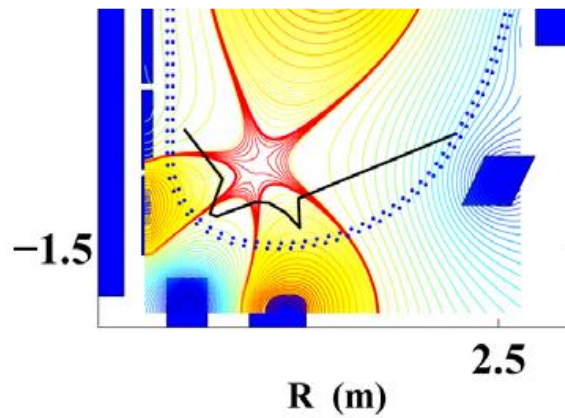

Y. Feng, Nucl. Fusion, **46**, 807 (2006)
 L Xue *et al*, Plasma Phys. Control. Fusion **58**, 055005 (2016)

Pros and cons of a divertor



- **Advantages:**
 - The collector plate is remote from the plasma. There is space available to spread out the magnetic lines.
 - A lower intensity of particles and energy bombard the collector plate leading to a longer replacement time.
 - It is more difficult for impurities to migrate into the plasma.
 - There are longer distance distances to travel and if a neutral particle becomes ionized before or during the time it crosses the divertor layer on its way toward the plasma, its parallel motion then carries it back to the collector plate.
 - The larger divertor chamber provides more access to pump out impurities.
 - The plasma edge is not in direct contact with a solid material such as a limiter.
- **Disadvantages:** larger and more complex system and more expensive.

Course Outline



- **Magnetic confinement fusion (MCF)**
 - Gyro motion, MHD
 - 1D equilibrium (z pinch, theta pinch)
 - Drift: ExB drift, grad B drift, and curvature B drift
 - Tokamak, Stellarator (toroidal field, poloidal field)
 - Magnetic flux surface
 - 2D axisymmetric equilibrium of a torus plasma: Grad-Shafranov equation.
 - Stability (Kink instability, sausage instability, Safety factor Q)
 - Central-solenoid (CS) start-up (discharge) and current drive
 - CS-free current drive: electron cyclotron current drive, bootstrap current.
 - Auxiliary Heating: ECRH, Ohmic heating, Neutral beam injection.

Collisions play an important role in ionization process



- At the microscopic level, breakdown requires the presence of sufficiently energy charge particles that have acquired enough energy from the applied electric field between two energy-dissipating collisions to ionize the material and to create more charge particles.

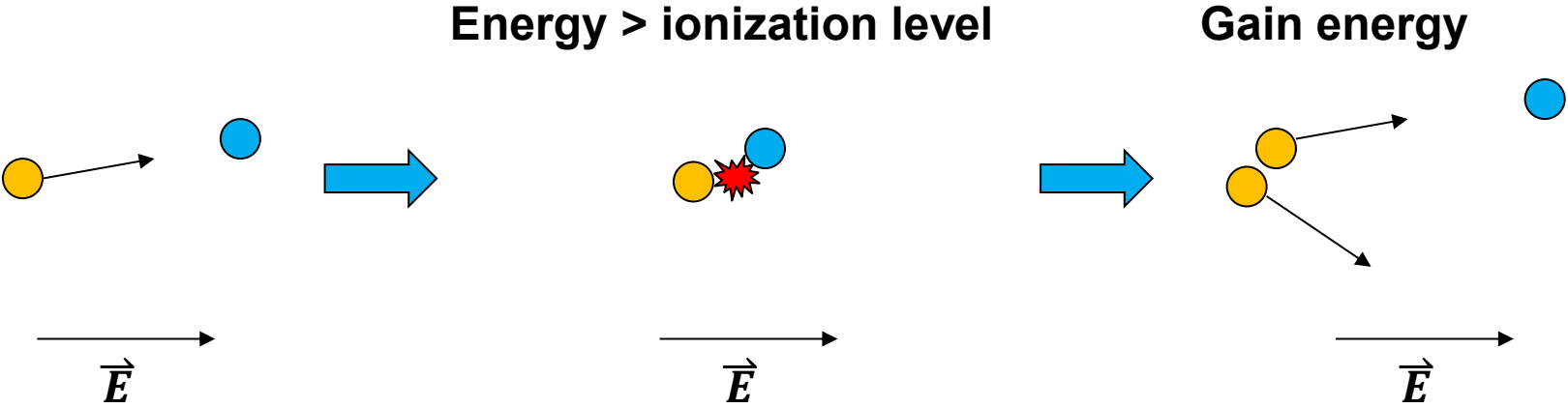

In most cases, electrons dominate the breakdown process since its mobility is much larger than that of ions



$$E_k = \frac{1}{2}mv^2 \quad v = \sqrt{\frac{2E_k}{m}} \quad E_k \sim kT$$

Collision time: $t = \frac{s}{\sqrt{\frac{2E_k}{m}}} \sim \frac{n^{-1/3}}{\sqrt{T}} \sqrt{m}$ $n = \frac{\#}{V} \sim \frac{\#//}{S^3}$ $s \sim n^{-1/3}$

$$\frac{m_i}{m_e} \sim 2000 \times \text{Atomic mass}$$

$$\frac{t_i}{t_e} \sim 45 \times \sqrt{A}$$

Mean free path is important in ionization process



- For an electron to acquire enough energy between collisions, its mean free path in the material must be sufficiently long.

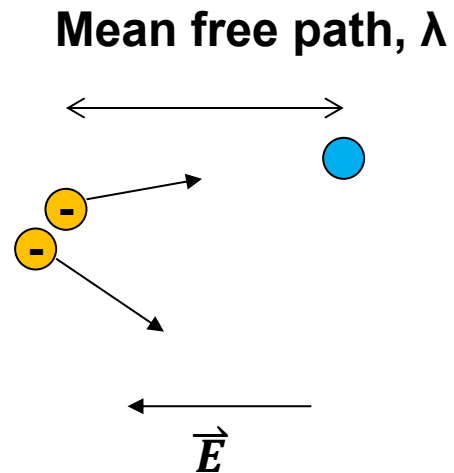

$$E_k = e \times E \times \lambda = eV$$

Electron impact ionization is the most important process in a breakdown of gases



- Electron impact ionization: $A + e^- \rightarrow A^+ + e^- + e^-$

- The most important process in the breakdown of gases but is not sufficient alone to result in the breakdown.

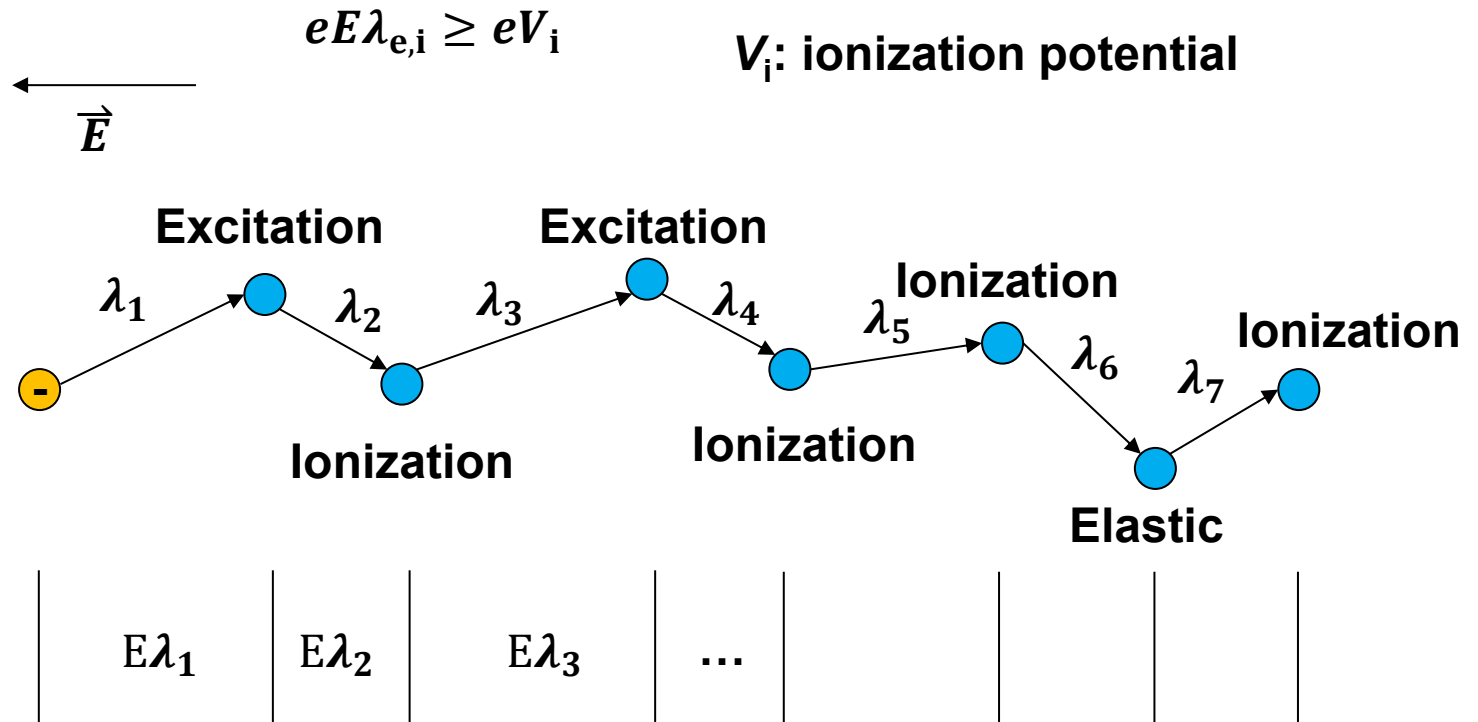

Collision cross-sections of elastic, ionizing collisions between e⁻ and H₂ and coulomb collisions

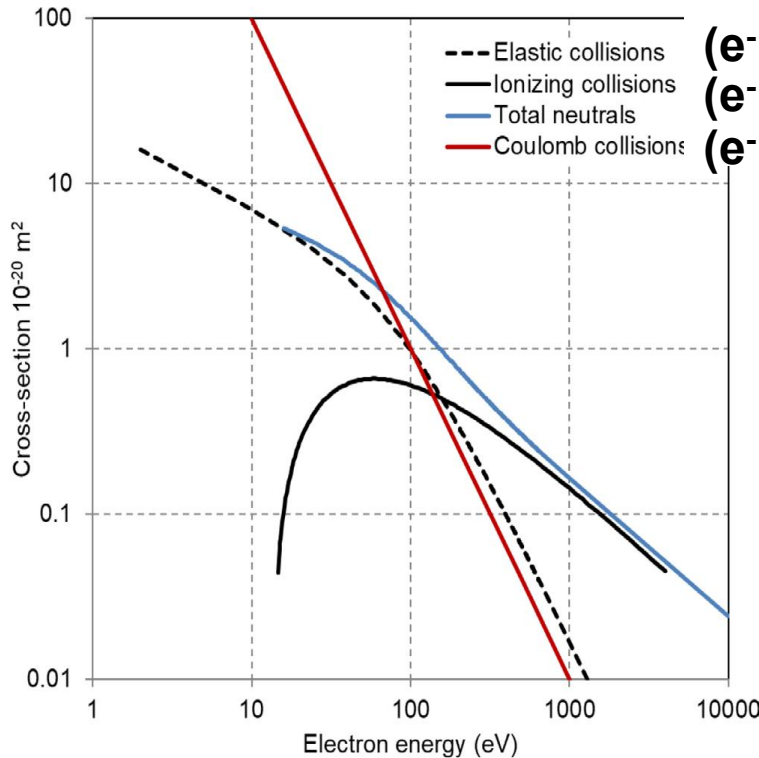

--- Elastic collisions (e⁻ vs H₂)
 — Ionizing collisions (e⁻ + H₂ → 2e⁻ + H⁺ + H)
 — Total neutrals
 — Coulomb collisions (e⁻ vs H⁺)

$$\sigma_{\text{elastic}, m^2} = \frac{1.75 \times 10^{-16}}{(W_{e, \text{eV}}^{1.5} + 750) \sqrt{W_{e, \text{eV}}}}$$

$$\sigma_{\text{ionizing}, m^2} \sim 3 \times 10^{-20} \left(\ln \epsilon - 0.69 + \frac{0.66}{\epsilon} \right) \epsilon^{-1}$$

$$\epsilon = \frac{W_e}{E_{\text{ion}}} \quad E_{\text{ion}} \sim 15 \text{ eV for H}_2$$

$$\sigma_{\text{coulomb}} = \frac{e^4}{4\pi\epsilon_0^2 m_e^2 v_e^2} \ln \Lambda$$

$$= \frac{e^4}{16\pi\epsilon_0^2 W_e^2} \ln \Lambda \sim 10^{-16} W_e^{-2}$$

for $\ln \Lambda \sim 13 - 15$

$$\nu = n v_E \sigma$$

$$\lambda = \frac{1}{n \sigma}$$

Townsend avalanche process for Tokamak breakdown



- The first Townsend coefficient α : the number of ionizing collisions made on the average by an electron as it travels 1 m along the electric field:

$$\alpha \sim \frac{1}{\lambda_i} = \frac{\nu_{ei}}{\bar{v}_e} = \frac{n_0 \langle \sigma v_e \rangle_{ne}}{\bar{v}_e} = \frac{p}{T} \frac{\langle \sigma v \rangle_{ne}}{\bar{v}_e} \equiv Ap \quad A \equiv \frac{1}{T} \frac{\langle \sigma v \rangle_{ne}}{\bar{v}_e}$$

- Number of primary electrons with energy higher than the ionization potential:

$$dn_e = -n_e \frac{dx_i}{\lambda_i} \Rightarrow \frac{n_e(x_i)}{n_{e0}} = \exp\left(-\frac{x_i}{\lambda_i}\right)$$

$$\alpha \equiv \frac{\text{\# / ionization collisions}}{\text{per electron}} \times (\text{\# / electron with } E > \text{ ionization potential})$$

$$= \frac{1}{\lambda_i} \frac{n_e(x_i)}{n_{e0}} = \frac{1}{\lambda_i} \exp\left(-\frac{x_i}{\lambda_i}\right)$$

$$A = 3.83 \text{ m}^{-1}\text{Pa}^{-1} = 1060 \text{ m}^{-1}\text{Torr}^{-1}$$

$$B = 96.6 \text{ Vm}^{-1}\text{Pa}^{-1} = 35000 \text{ m}^{-1}\text{Torr}^{-1}$$

$$\alpha = Ap \exp(-Ap x_i)$$

$$\alpha = Ap \exp\left(-\frac{AV^*}{E/p}\right) \equiv Ap \exp\left(-\frac{B}{E/p}\right) \quad x_i \approx \frac{V^*}{E} \text{ where } V^* > V_i$$

- The parameters A and B must be experimentally determined.

Paschen-like curve for minimum breakdown voltage



$$\alpha \sim \frac{1}{\lambda_i} = Ap \quad \alpha = Ap \exp\left(-\frac{B}{E/p}\right)$$

$$A = 3.83 \text{ m}^{-1}\text{Pa}^{-1} = 1060 \text{ m}^{-1}\text{Torr}^{-1}$$

$$B = 96.6 \text{ Vm}^{-1}\text{Pa}^{-1} = 35000 \text{ m}^{-1}\text{Torr}^{-1}$$

- For $p=1 \text{ mPa}$, $\lambda_i \sim 262 \text{ m}$, for ITER, $2\pi r_0 \sim 38 \text{ m}$ $\frac{\lambda_i}{2\pi r_0} \sim 7$

- For breakdown to happen:

$$\alpha L > 1 \quad \alpha L = ApL \exp\left(-\frac{BpL}{V_{BD}}\right) > 1$$

$$\exp\left(-\frac{BpL}{V_{BD}}\right) > \frac{1}{ApL}$$

$$-\frac{BpL}{V_{BD}} > -\ln(ApL)$$

$$V_{BD} > \frac{BpL}{\ln(ApL)} \quad E_{BD} > \frac{Bp}{\ln(ApL)}$$

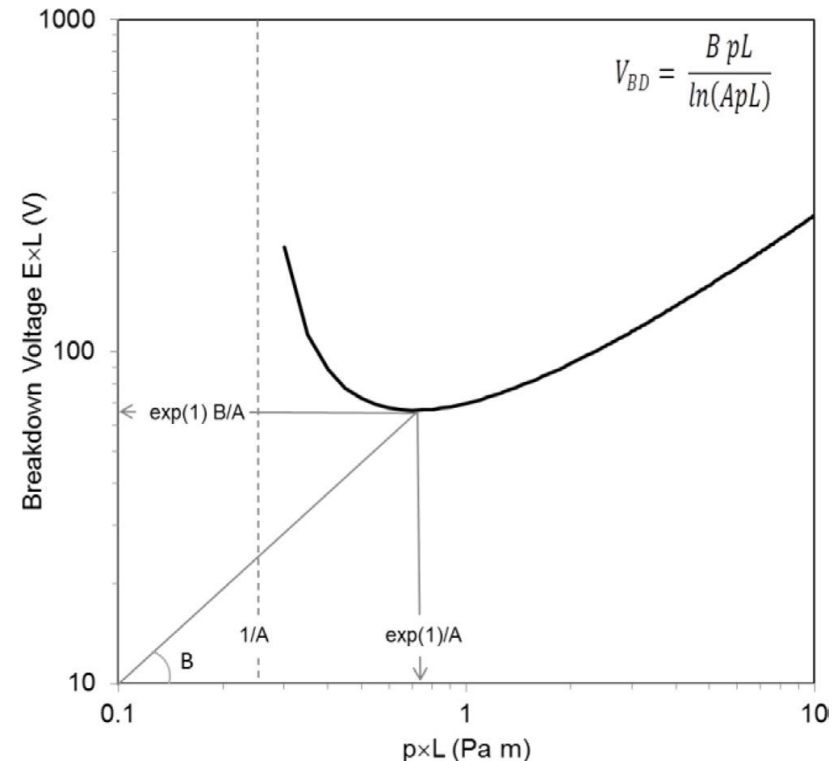

Perpendicular stray-field (B_z) needs to be as small as possible



- For $p=1$ mPa, $\lambda_i \sim 262$ m, for ITER, $2\pi r_0 \sim 38$ m $\frac{\lambda_i}{2\pi r_0} \sim 7$

$$\frac{B_z}{B_T} \sim 10^{-3} \quad \lambda_i \times \frac{B_z}{B_T} = 0.26 \text{ m}$$

- For ITER,

$$E \sim E_{\text{loop}} = 0.3 \text{ V/m}$$

$$p = 1 \text{ mPa} \quad L_{\text{BD}} = 357 \text{ m}$$

- Required loop field:

$$E_{\text{BD}} > \frac{Bp}{\ln(ApL)}$$

$$E_{\text{BD}} > \frac{1.25 \times 10^4 P_{\text{Torr}}}{\ln(510PL_c)}$$

$$L_c = 0.25 a_{\text{eff}} \left(\frac{B_z}{B_T} \right)$$

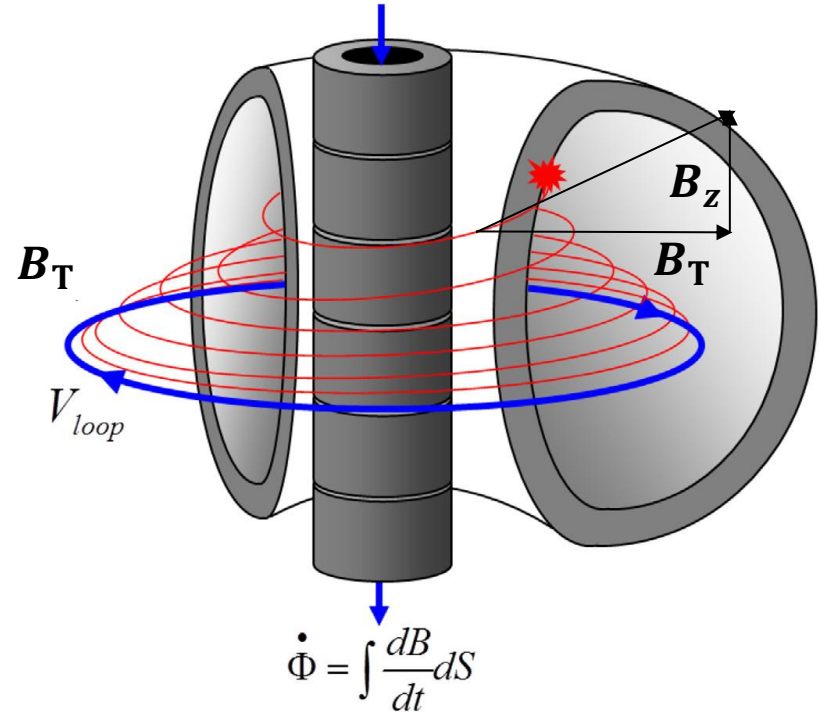

- W/ preionization: $E_T \frac{B_T}{B_z} \geq 100 \text{ V/m}$
- Purely Ohmic discharges: $E_T \frac{B_T}{B_z} \geq 1000 \text{ V/m}$

Examples or required loop electric fields



$$E_{BD} > \frac{1.25 \times 10^4 P_{Torr}}{\ln(510PL_c)}$$

$$L_c = 0.25 a_{eff} \left(\frac{B_z}{B_T} \right)$$

- W/ preionization: $E_T \frac{B_T}{B_z} \geq 100 \text{ V/m}$

- Purely Ohmic discharges: $E_T \frac{B_T}{B_z} \geq 1000 \text{ V/m}$

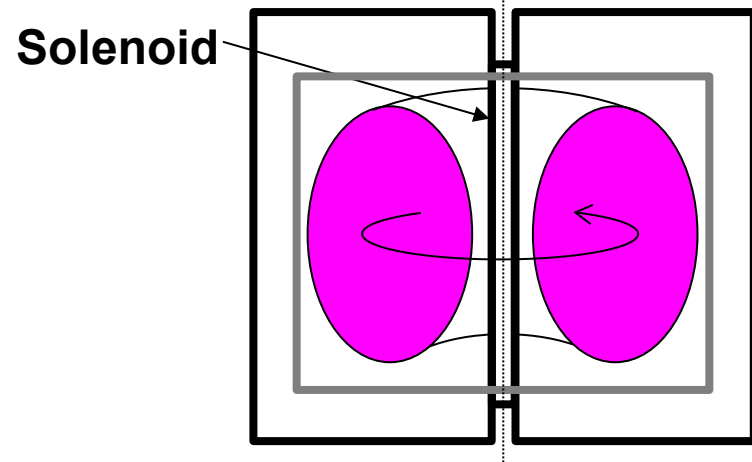
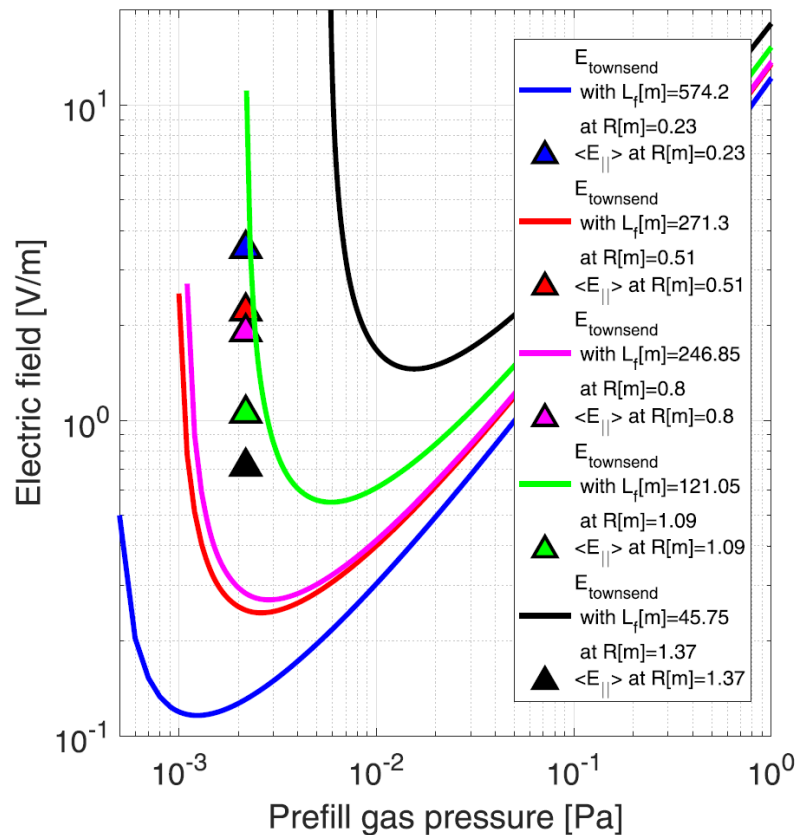

$$V_\phi = -\frac{\partial \phi}{\partial t} \equiv M \frac{\partial I_{CS}}{\partial t}$$

$$E_\phi = -\frac{1}{2\pi r} \frac{\partial \phi}{\partial t}$$

Central solenoid can be used to provide the required loop voltage for breakdown



- SMART:

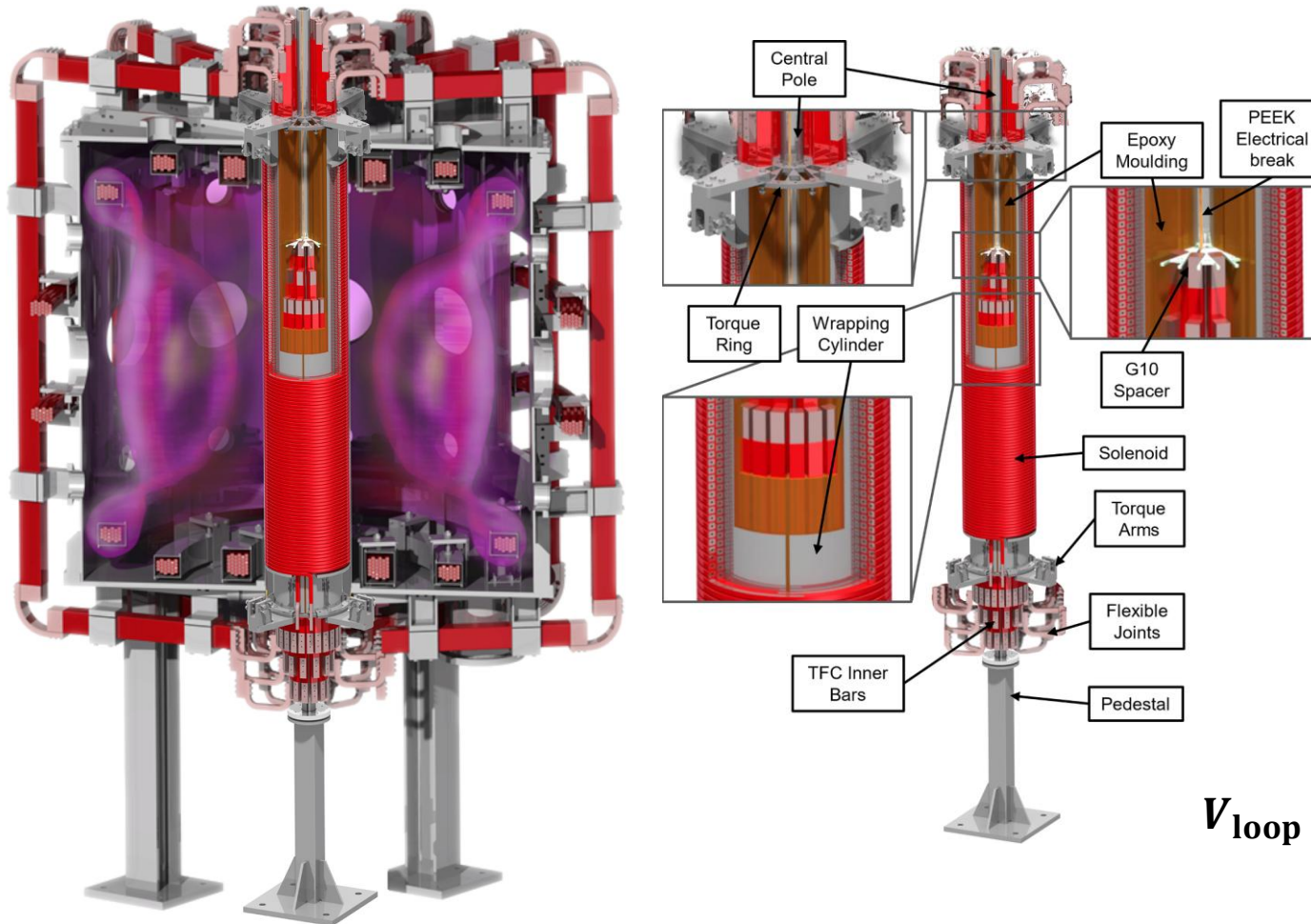

$$V_{\text{loop}} = \frac{A_{\text{sol}} \mu N_{\text{sol}}}{L_{\text{sol}}} \frac{dI_{\text{sol}}}{dt}$$

Poloidal coils are used to reduce the stray field during breakdown

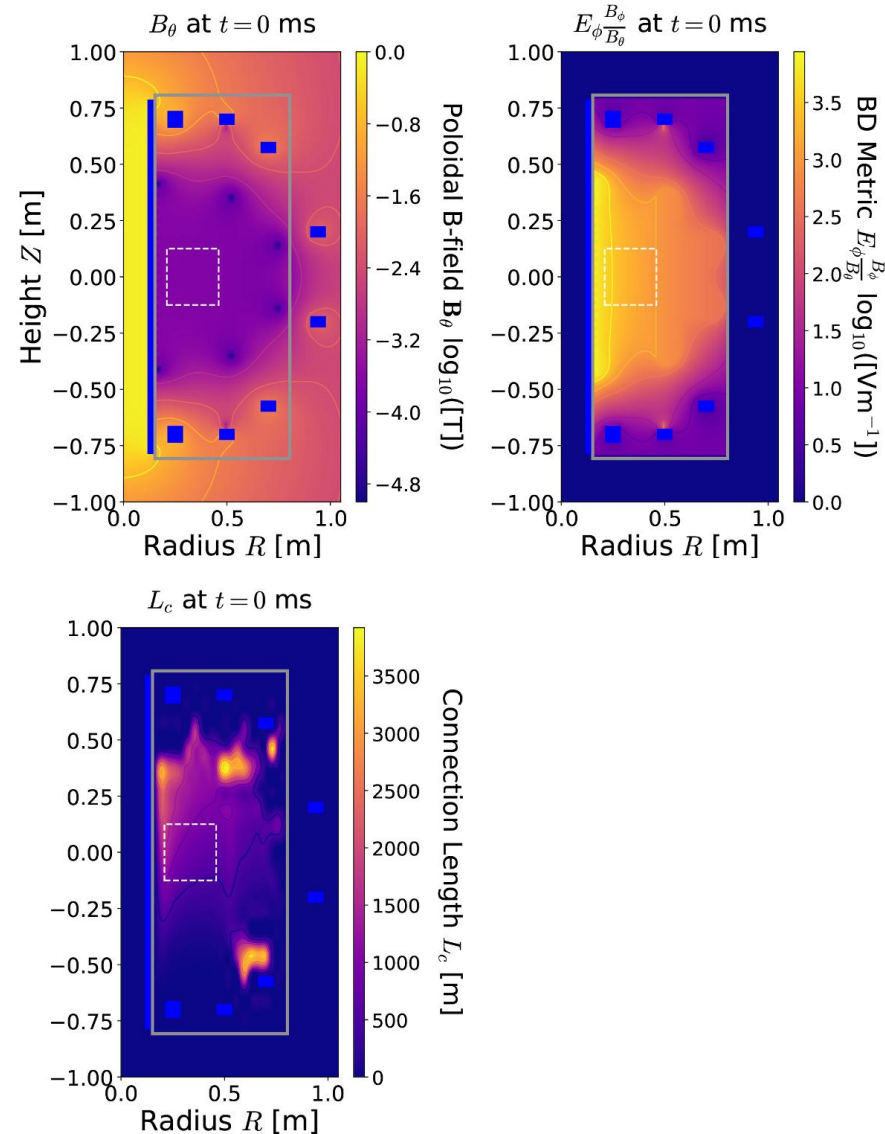

• Currents of SMART

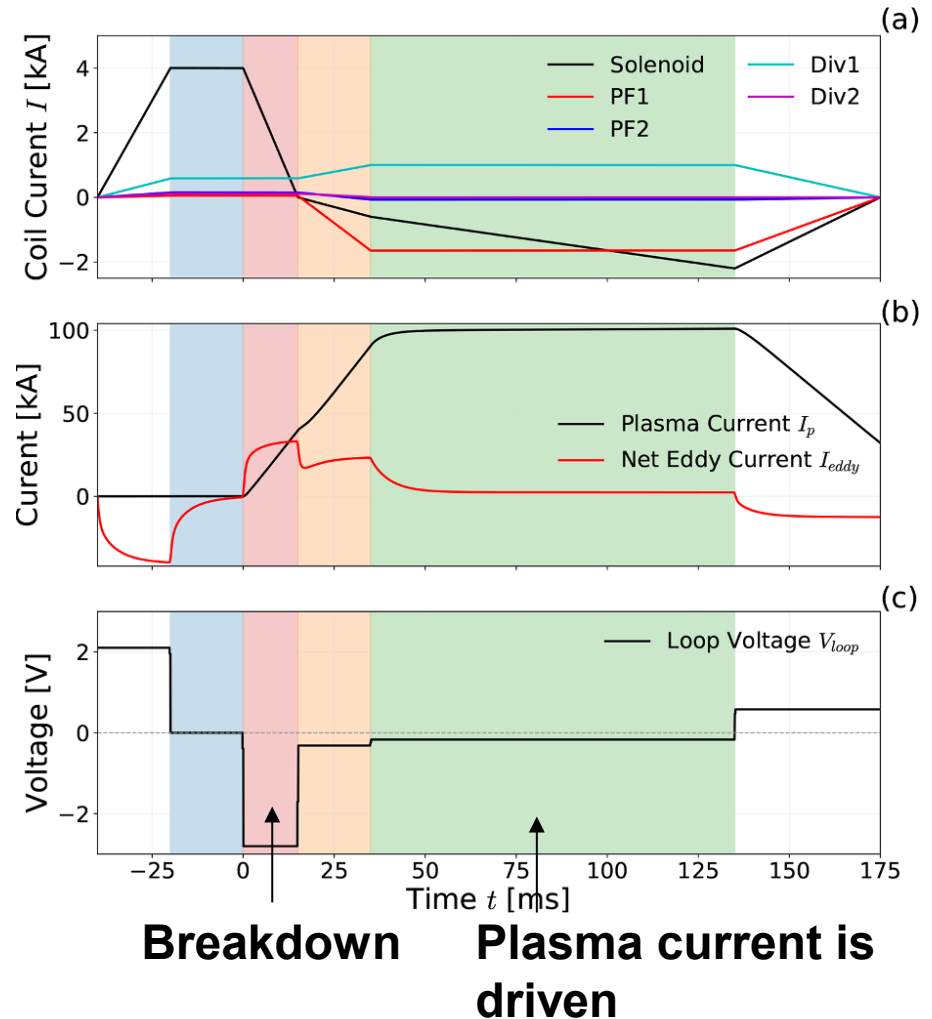

Momentum exchange may be needed to drive plasma current

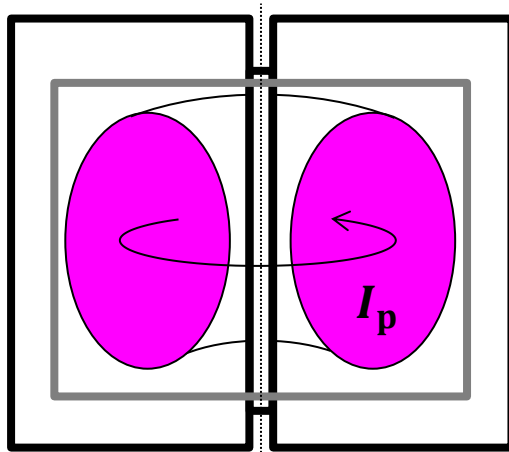

$$\vec{j}_p = \Sigma qn \vec{v} = -en_e \vec{v}_e + en_i \vec{v}_i$$

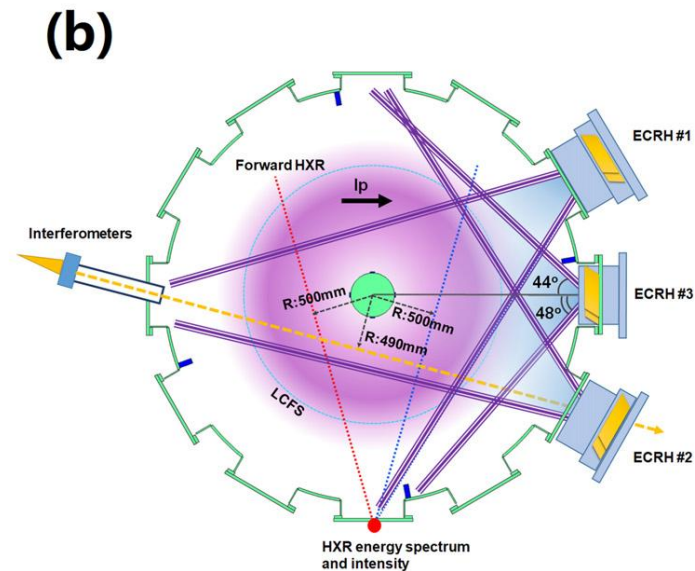
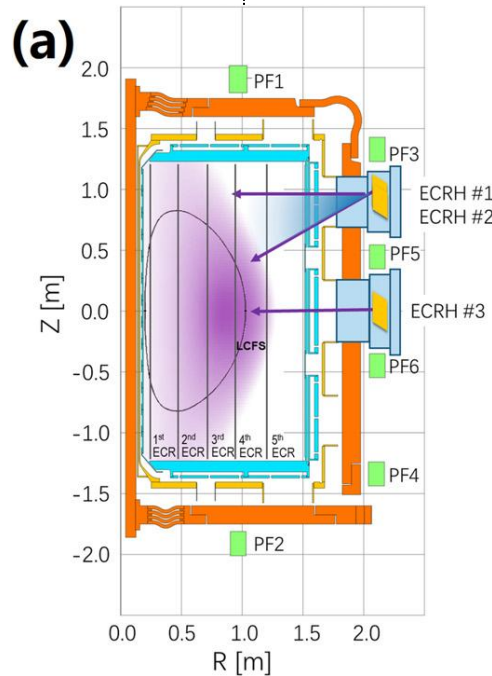

Solenoid can be used to drive the plasma current



$$L_{\text{tor}} \frac{dI}{dt} + IR = V_{\text{loop}} = M \frac{dI_{\text{sol}}}{dt}$$

$$L_{\text{tor}} = \mu_0 r_0 \left[\ln \left(\frac{8r_0}{a} \right) - 1.5 \right]$$

$$R_{\text{spitzer}} = \eta_{\text{spitzer}} \frac{2\pi r_0}{A_{\text{tor}}}$$

$$\eta_{\text{spitzer}} = 5.2 \times 10^{-3} Z \ln \Lambda T_{e,(\text{eV})}^{-3/2}$$

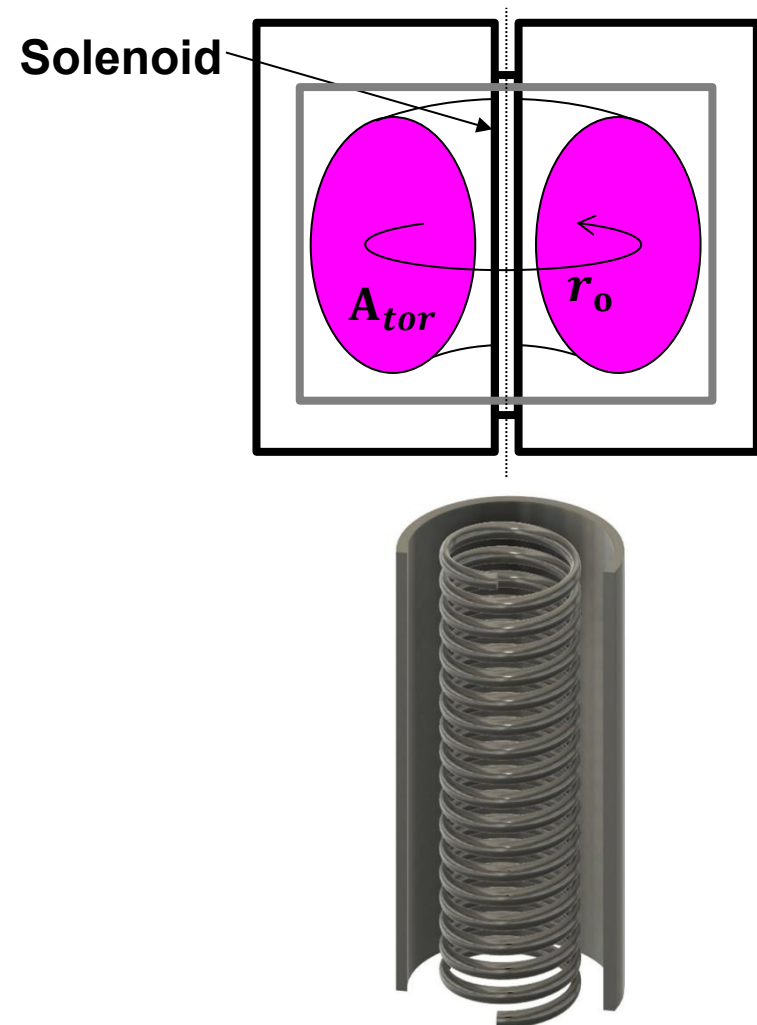

Current is initially driven at the surface and then diffuses into the plasma



- Simplified Ohm's law: $\vec{E} + \vec{v} \times \vec{B} = \eta \vec{j}$
- Assuming a stationary plasma: $\nabla \times \vec{E} = -\frac{\partial \vec{B}}{\partial t} = \nabla \times (\eta \vec{j})$
- Assuming a constant η :

$$-\frac{\partial}{\partial t} \nabla \times \vec{B} = \eta \nabla \times \nabla \times \vec{j} = \eta (\nabla(\nabla \cdot \vec{j}) - \nabla^2 \vec{j})$$

$$\frac{\partial \vec{j}}{\partial t} = \frac{\eta}{\mu_0} \nabla^2 \vec{j}$$

- Assuming non-constant η :

$$\frac{\partial \vec{j}}{\partial t} = \frac{1}{\mu_0} \nabla^2 (\eta \vec{j}) - \nabla [\nabla \cdot (\mu \vec{j})] \qquad \frac{\partial j_T}{\partial t} = \frac{1}{\mu_0} \nabla^2 (\eta j_T)$$

- Since $\eta \propto T^{-3/2}$, resistance drops with higher temperature. The typical limited temperature is ~ 3 keV.

Eddy current needed to be considered

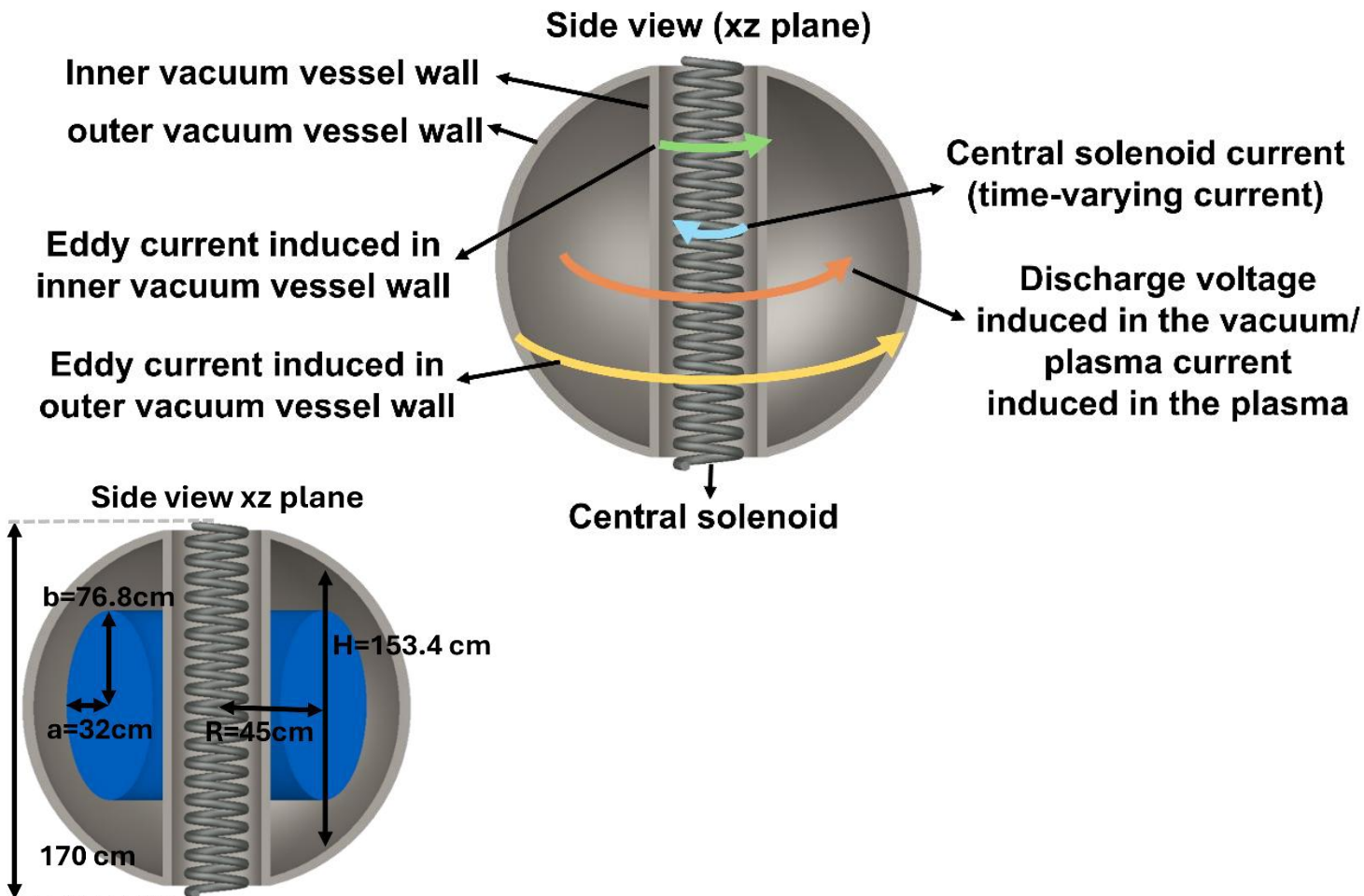

Chamber is broken into ring elements carrying eddy currents

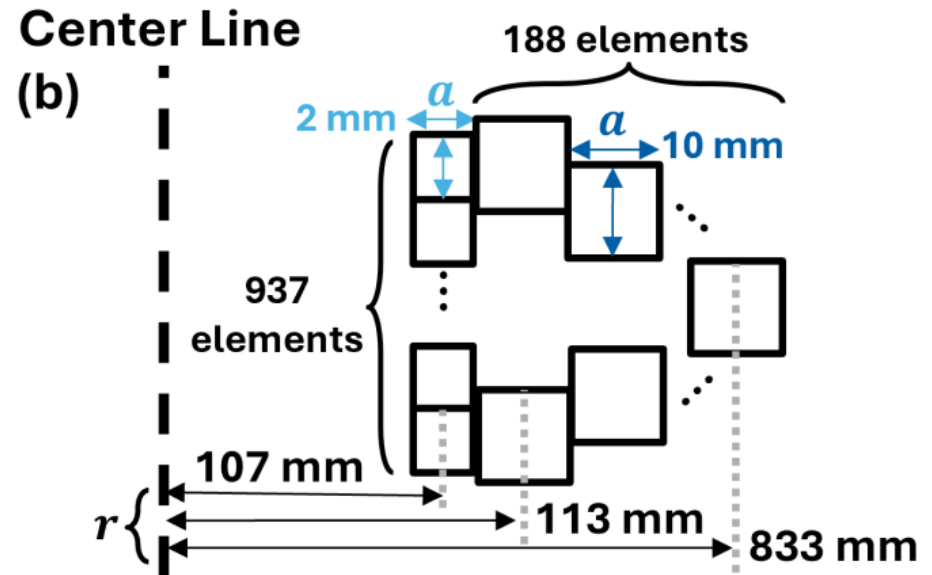
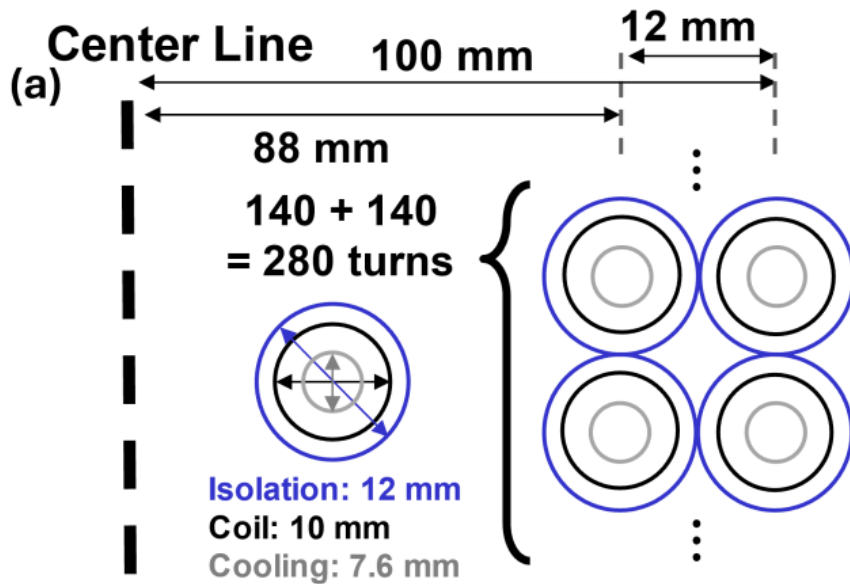

The eddy current in each chamber element is solved numerically



$$\overleftrightarrow{M} \frac{d\vec{I}}{dt} + \overleftrightarrow{R}_\Omega \vec{I} = \vec{V} \quad \overleftrightarrow{M} \frac{\vec{I}' - \vec{I}}{\Delta t} + \overleftrightarrow{R}_\Omega \vec{I} = \vec{V}$$

$$\vec{I}' = \left(\overleftrightarrow{1} - \Delta t \overleftrightarrow{M}^{-1} \overleftrightarrow{R}_\Omega \right) \vec{I} + \Delta t \overleftrightarrow{M}^{-1} \vec{V}$$

$$\vec{V} = \overleftrightarrow{M} \frac{d\vec{I}}{dt} + \overleftrightarrow{R}\vec{I}$$

$$\Rightarrow \begin{bmatrix} V_{c1} \\ V_{c2} \\ \vdots \\ V_{v1} \\ V_{v2} \\ \vdots \\ V_p \end{bmatrix} = \begin{bmatrix} L_{c1} & M_{c1,c2} & M_{c1,c3} & \cdots & M_{c1,v1} & M_{c1,v2} & M_{c1,v3} & \cdots & M_{c1,p} \\ M_{c2,c1} & L_{c2} & M_{c2,c3} & \cdots & M_{c2,v1} & M_{c2,v2} & M_{c2,v3} & \cdots & M_{c2,p} \\ M_{c3,c1} & M_{c3,c2} & L_{c3} & \cdots & M_{c3,v1} & M_{c3,v2} & M_{c3,v3} & \cdots & M_{c3,p} \\ \vdots & \vdots & \vdots & \vdots & \vdots & \vdots & \vdots & \vdots & \vdots \\ M_{v1,c1} & M_{v1,c2} & M_{v1,c3} & \cdots & L_{v1} & M_{v1,v2} & M_{v1,v3} & \cdots & M_{v1,p} \\ M_{v2,c1} & M_{v2,c2} & M_{v2,c3} & \cdots & M_{v2,v1} & L_{v2} & M_{v2,v3} & \cdots & M_{v2,p} \\ M_{v3,c1} & M_{v3,c2} & M_{v3,c3} & \cdots & M_{v3,v1} & M_{v3,v2} & L_{v3} & \cdots & M_{v3,p} \\ \vdots & \vdots & \vdots & \vdots & \vdots & \vdots & \vdots & \vdots & \vdots \\ M_{p,c1} & M_{p,c2} & M_{p,c3} & \cdots & M_{p,v1} & M_{p,v2} & M_{p,v3} & \cdots & L_p \end{bmatrix} \begin{bmatrix} I'_{c1} \\ I'_{c2} \\ \vdots \\ I'_{v1} \\ I'_{v2} \\ \vdots \\ I'_p \end{bmatrix} + \begin{bmatrix} R_{c1} & 0 & \cdots & 0 & 0 & \cdots & 0 \\ 0 & R_{c2} & \cdots & 0 & 0 & \cdots & 0 \\ \vdots & \vdots & \vdots & \vdots & \vdots & \vdots & \vdots \\ 0 & 0 & \cdots & R_{v1} & 0 & \cdots & 0 \\ 0 & 0 & \cdots & 0 & R_{v2} & \cdots & 0 \\ \vdots & \vdots & \vdots & \vdots & \vdots & \vdots & \vdots \\ 0 & 0 & \cdots & 0 & 0 & \cdots & R_p \end{bmatrix} \begin{bmatrix} I_{c1} \\ I_{c2} \\ \vdots \\ I_{v1} \\ I_{v2} \\ \vdots \\ I_p \end{bmatrix} \quad (2)$$

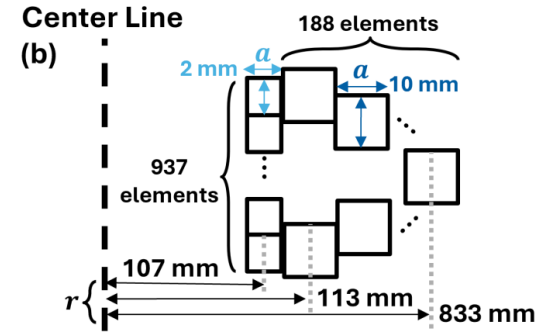

Eddy current on the chamber wall is induced when the current of the solenoid changes with time

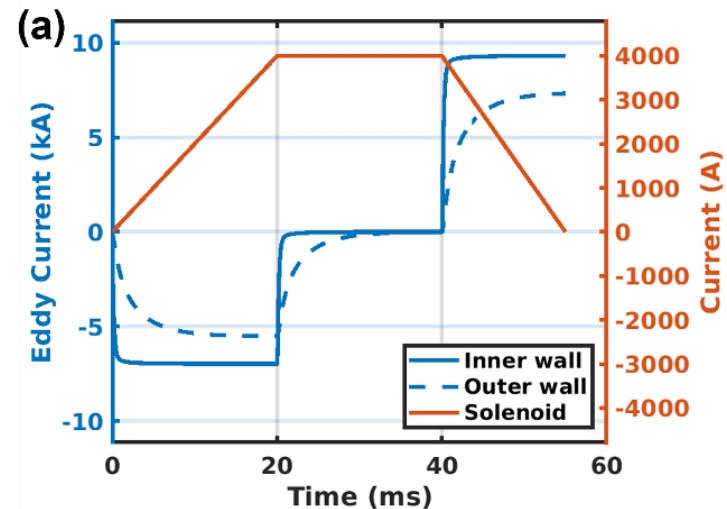
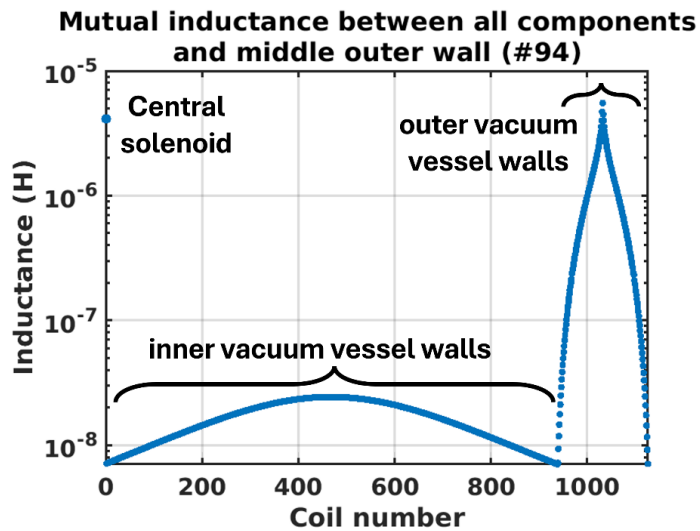
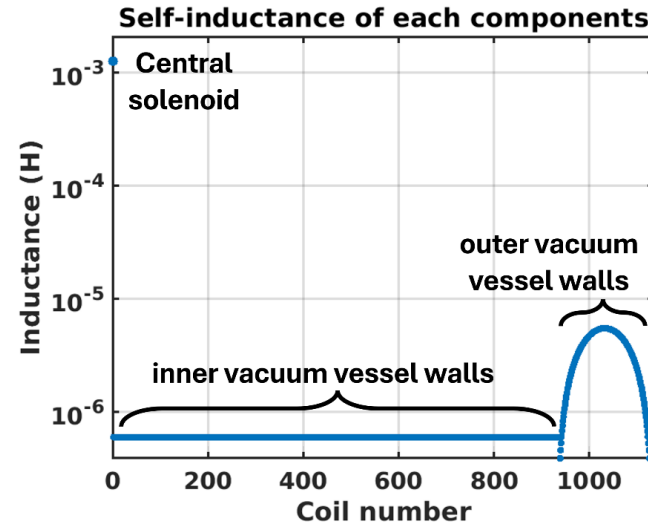
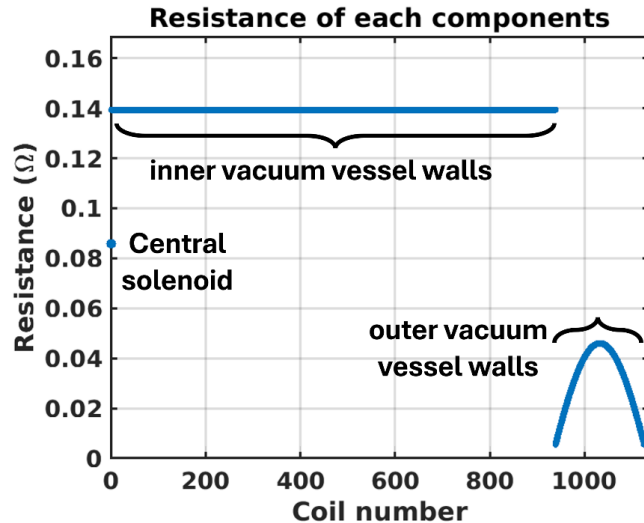

Temperature of 100 eV is the threshold of radiation barrier by impurities

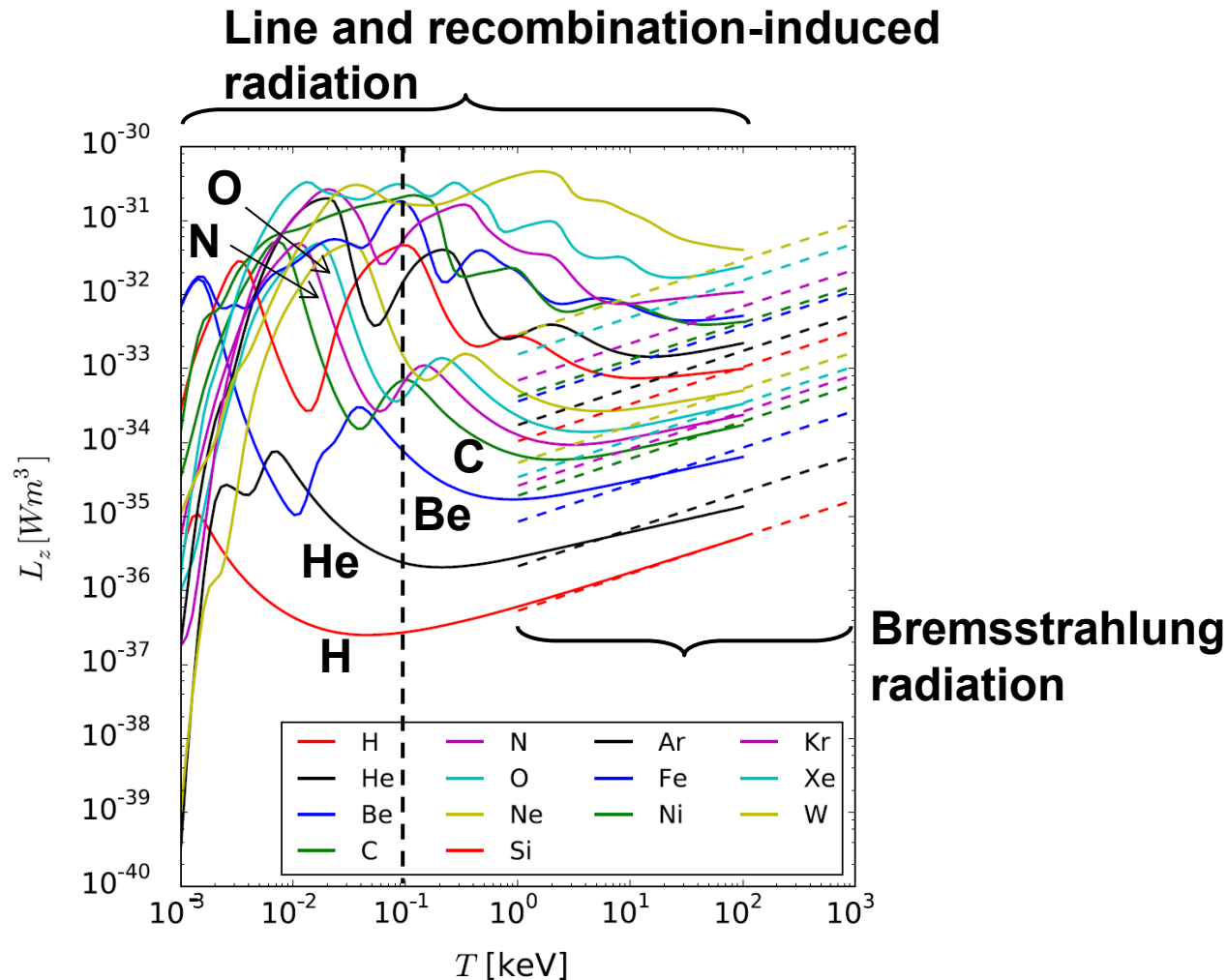

Plasma temperature can be estimated using the simple circuit model

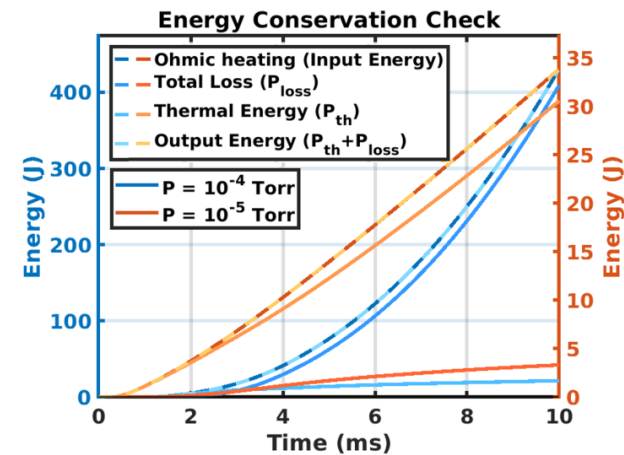
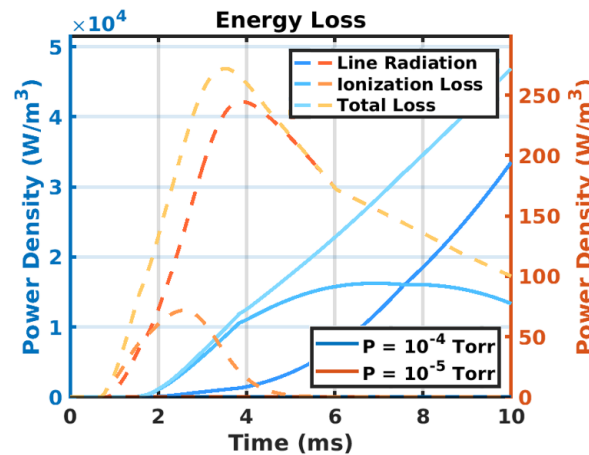
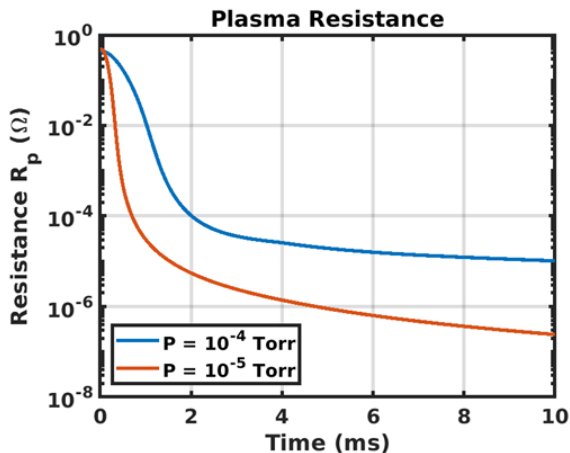
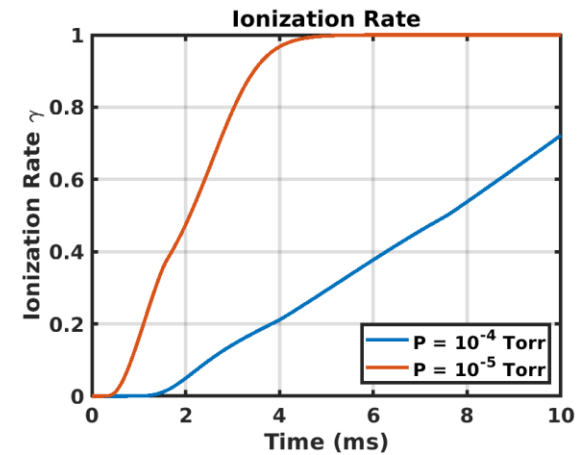
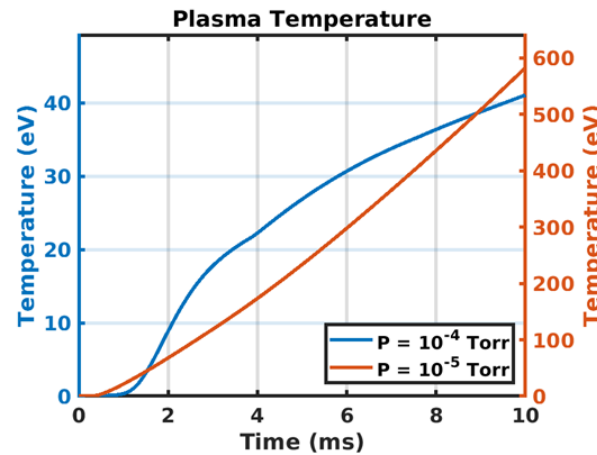
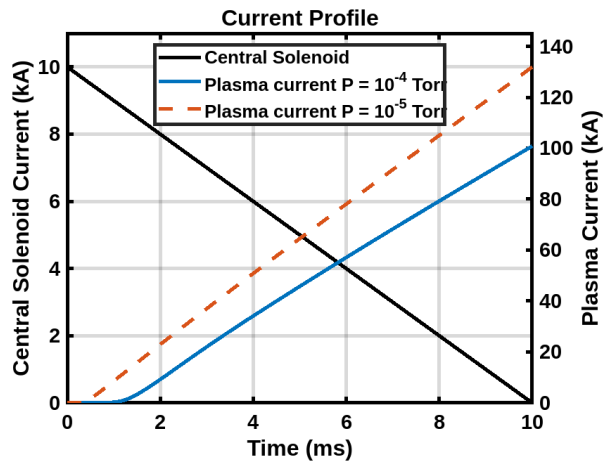

The collisional re-distribution of the ECRH-driven anisotropy in E_{\perp} causes some parallel momentum to flow from e^{-} to ions



- Coulomb collisions are more efficient at lower energies.

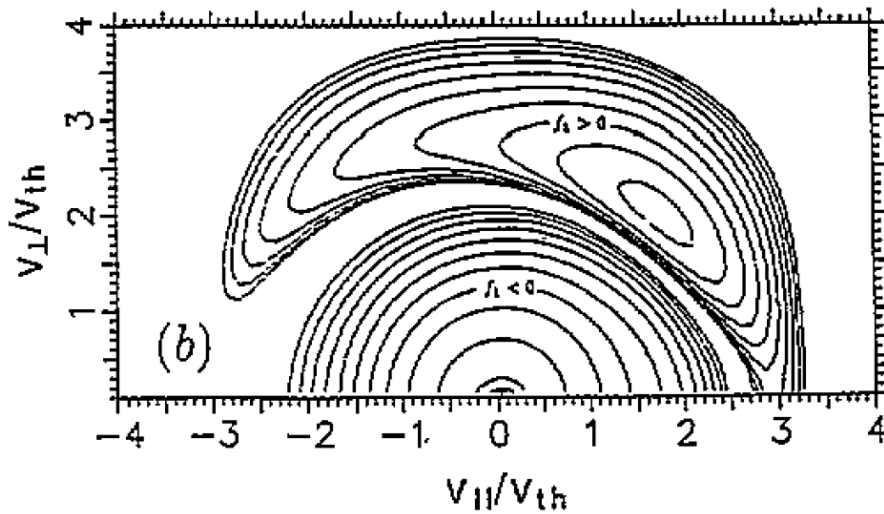

- Electron cyclotron current drive:

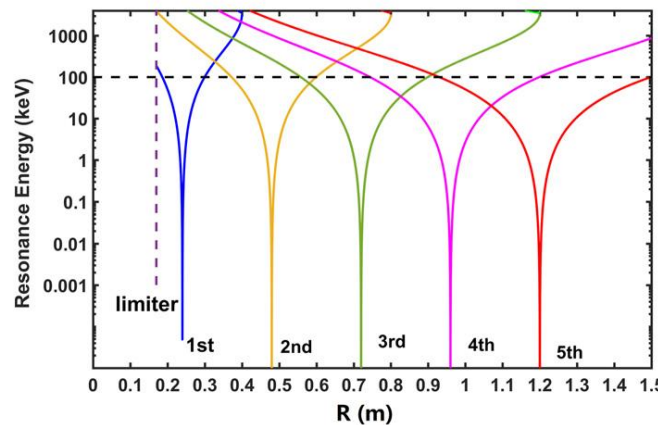

Velocity: $v_2 > v_1$

Collisions: $v_2 < v_1$

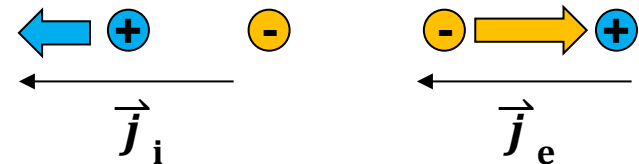

$$\vec{j}_p = -en_e \vec{v}_e + en_i \vec{v}_i$$

$$\vec{P} = n_e m_e \vec{v}_e + n_i m_i \vec{v}_i \approx 0$$

Passing electrons can be trapped if the v_{\perp} is increased by heating

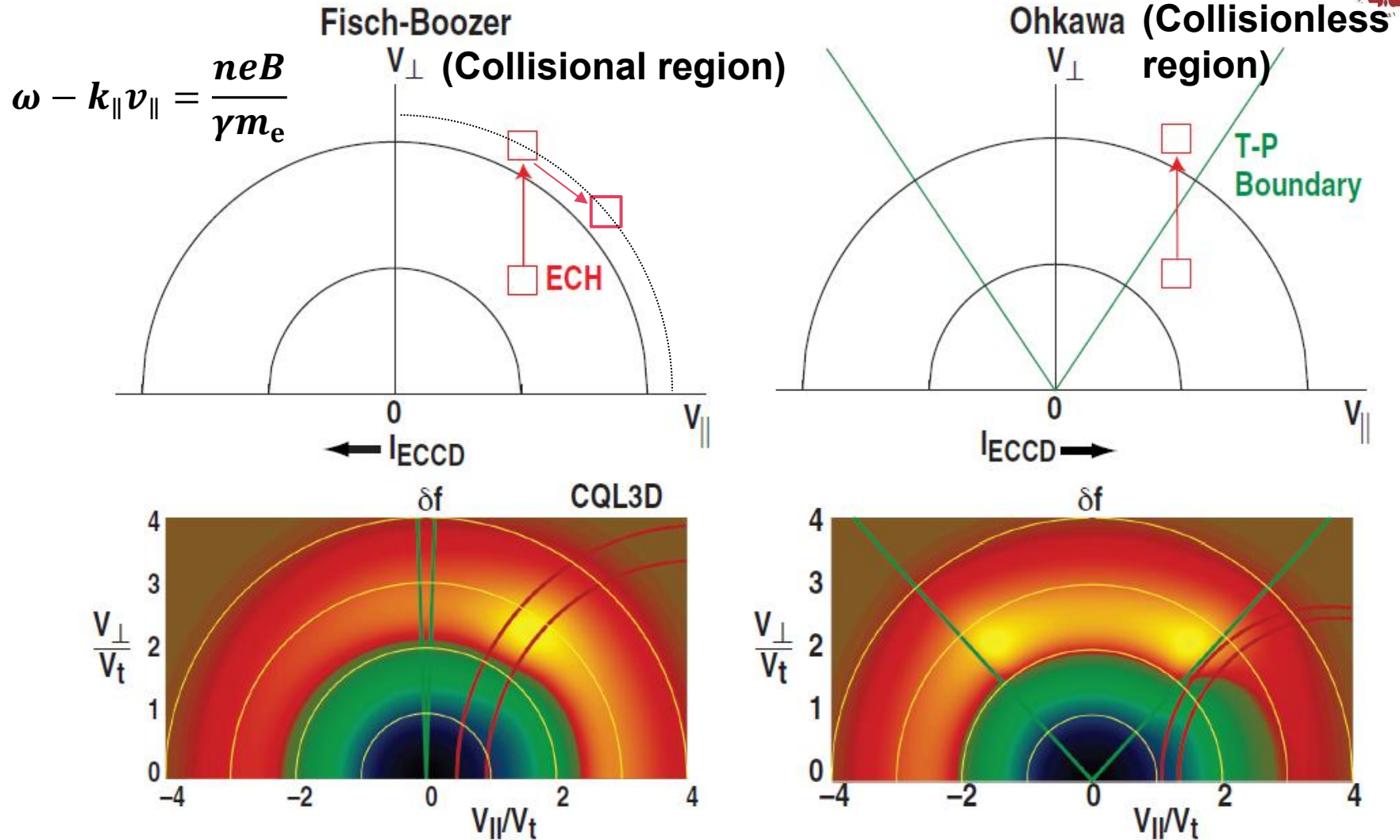

Comparison of Fisch-Boozer Mechanism and Ohkawa Mechanism



Aspect	Fisch–Boozer Mechanism ^[1]	Ohkawa Mechanism ^[2]
Physical Process	Asymmetric heating of passing electrons with subsequent collisional momentum transfer	Selective de-trapping of barely trapped electrons into passing orbits (collisionless mechanism)
Requires collisions?	Yes (collisional mechanism)	No (collisionless pitch-angle scattering)
Key Particle Population	Passing electrons	Trapped (or barely trapped) electrons
Wave absorption location	Depends on Doppler-shifted resonance; typically near magnetic axis or mid-radius	Usually near edge where barely trapped particles are abundant

1 N. J. Fisch and A. H. Boozer, Phys. Rev. Lett. 45, 720 (1980).

2 T. Ohkawa, “Steady state operation of tokamaks by rf heating,” General Atomics Report No. GA-A13847 (1976).

Strong absorption occurs when the frequency matches the electron cyclotron frequency



- Electron cyclotron resonance (ECR) plasma reactor

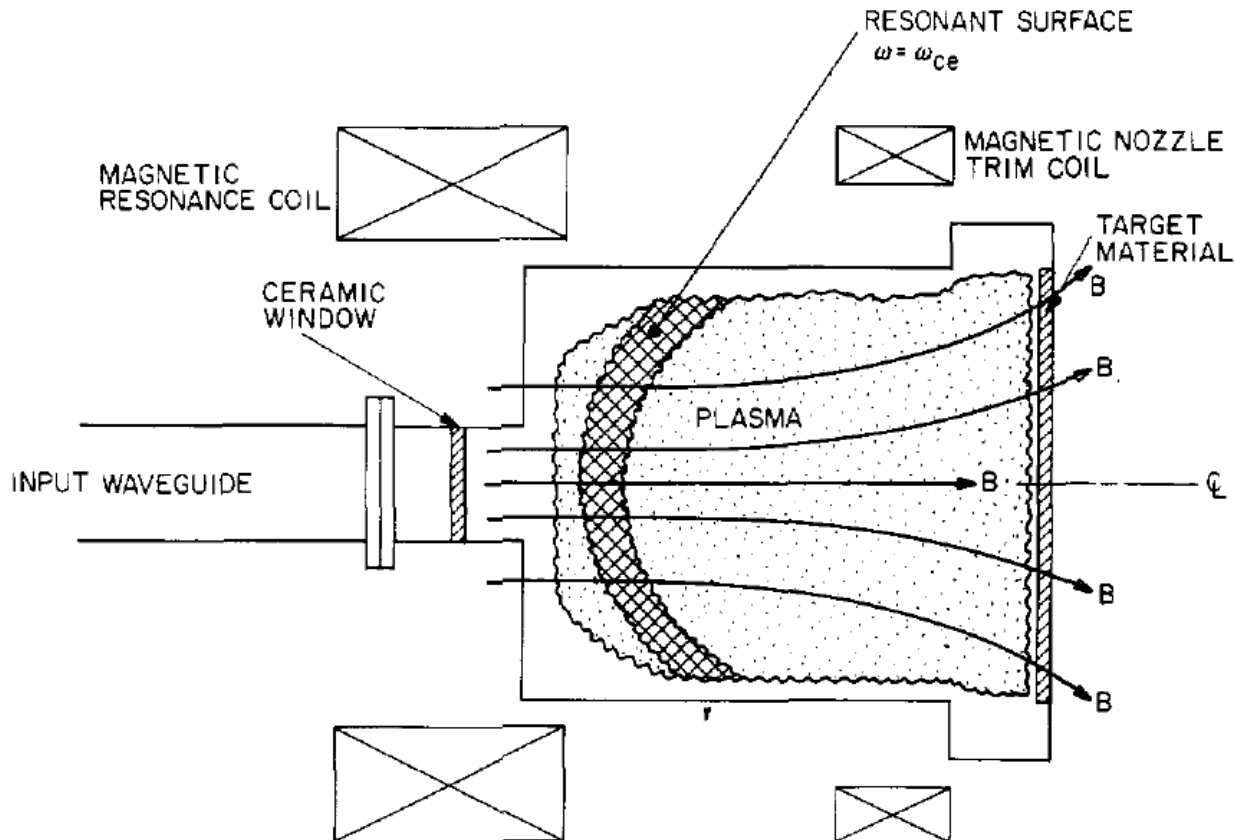

Electron cyclotron frequency depends on magnetic field only



$$m_e \frac{d\vec{v}}{dt} = -\frac{e}{c} \vec{v} \times \vec{B}$$

- Assuming $\vec{B} = B\hat{z}$ and the electron oscillates in x-y plane

$$m_e \dot{v}_x = -\frac{e}{c} B v_y \quad m_e \dot{v}_z = 0$$

$$m_e \dot{v}_y = \frac{e}{c} B v_x$$

$$\ddot{v}_x = -\frac{eB}{m_e c} \dot{v}_y = -\left(\frac{eB}{m_e c}\right)^2 v_x$$

$$\ddot{v}_y = -\frac{eB}{m_e c} \dot{v}_x = -\left(\frac{eB}{m_e c}\right)^2 v_y$$

- Therefore

$$\omega_{ce} = \frac{eB}{m_e c}$$

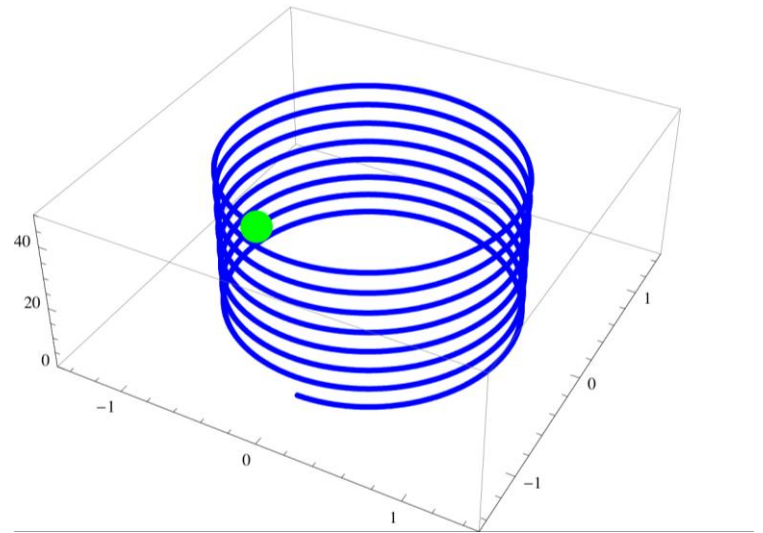

Electrons keep getting accelerated when a electric field rotates in electron's gyrofrequency



$$m_e \frac{d\vec{v}}{dt} = -\frac{e}{c} \vec{v} \times \vec{B} - e \vec{E} \quad \vec{B} = B_0 \hat{z} \quad \vec{E} = E_0 [\hat{x} \cos(\omega t) + \hat{y} \sin(\omega t)]$$

$$m_e \dot{v}_x = -\frac{e}{c} B v_y + E_0 \cos(\omega t) \quad m_e \dot{v}_y = \frac{e}{c} B v_x + E_0 \sin(\omega t) \quad m_e \dot{v}_z = 0$$

$$\ddot{v}_x = -\frac{eB}{m_e c} \dot{v}_y - \frac{E_0}{m_e} \omega \sin(\omega t) = -\omega_{ce}^2 v_x - \frac{E_0}{m_e} (\omega_{ce} + \omega) \sin(\omega t)$$

$$\ddot{v}_y = -\frac{eB}{m_e c} \dot{v}_x + \frac{E_0}{m_e} \omega \cos(\omega t) = -\omega_{ce}^2 v_y + \frac{E_0}{m_e} (\omega_{ce} + \omega) \cos(\omega t)$$

$$\omega_{ce} = \frac{eB}{m_e c}$$

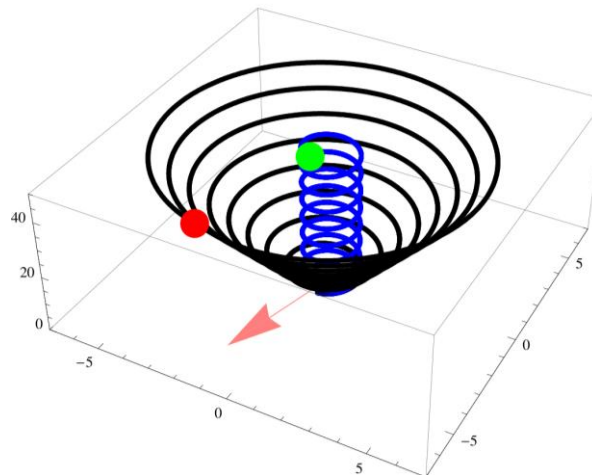

Electric field in a circular polarized electromagnetic wave keeps rotating as the wave propagates



- Right-handed polarization

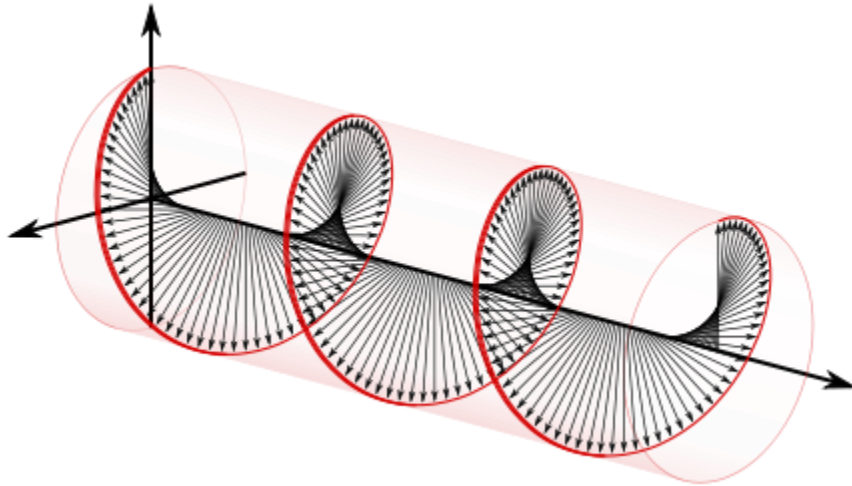

- Left-handed polarization

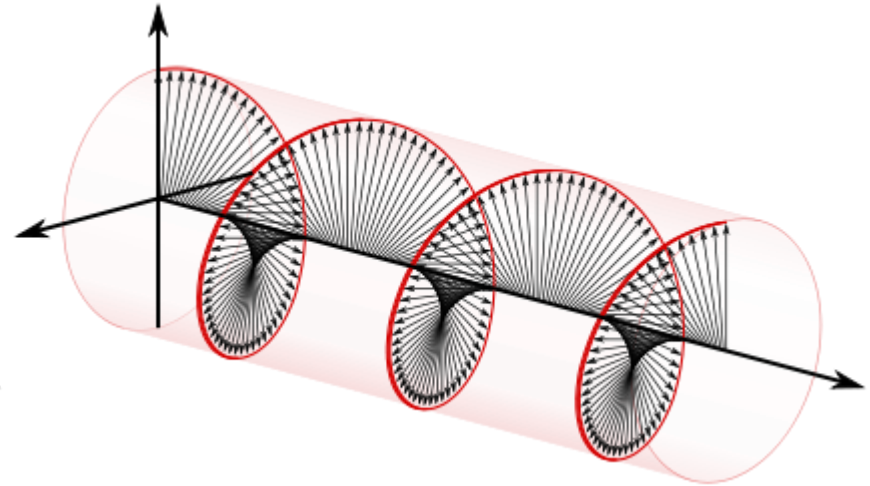

Only right-handed polarization can resonance with electron's gyromotion

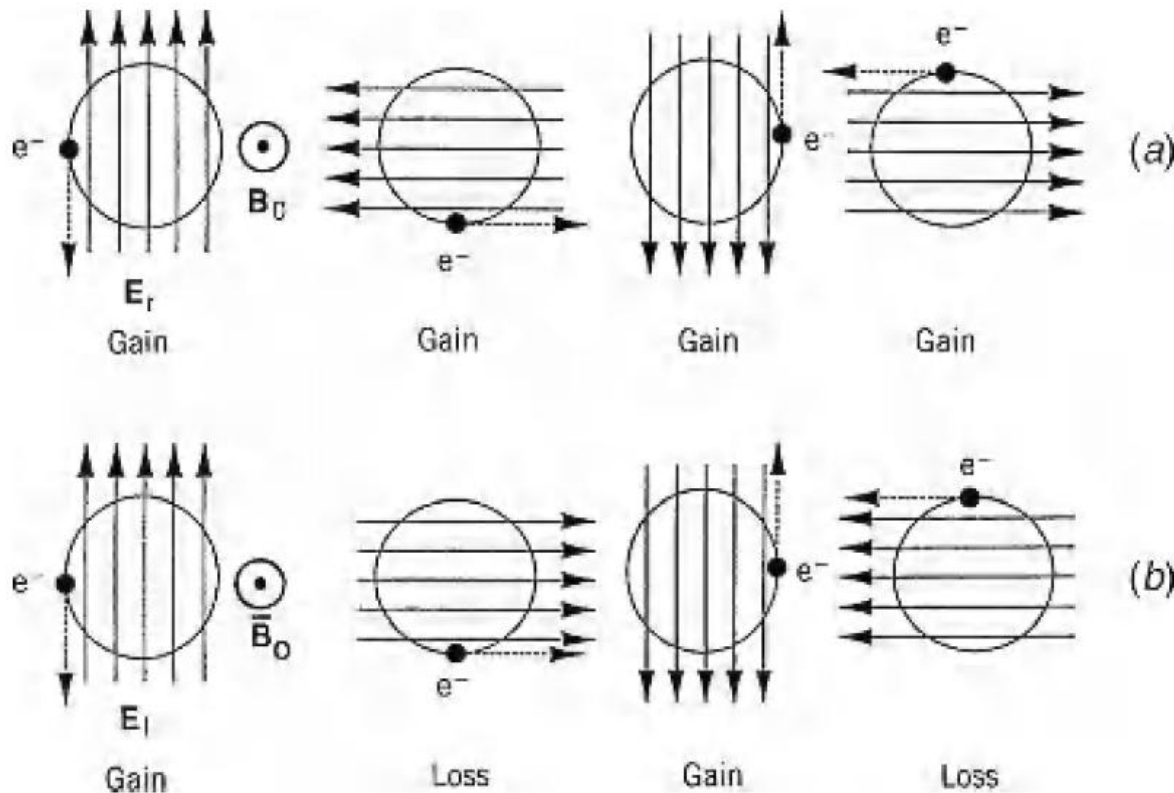
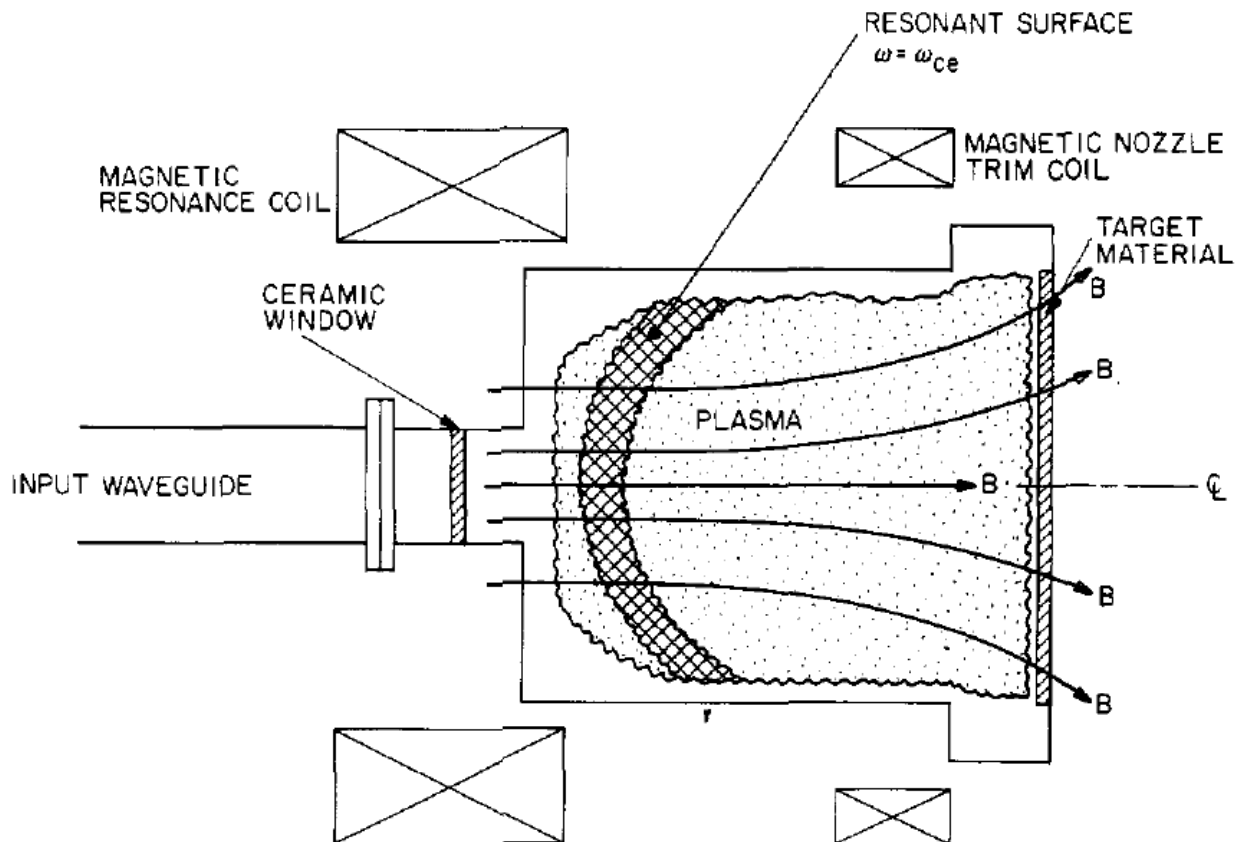

FIGURE 13.5. Basic principle of ECR heating: (a) continuous energy gain for right-hand polarization; (b) oscillating energy for left-hand polarization (after Lieberman and Gottscho, 1994).

Strong absorption occurs when the frequency matches the electron cyclotron frequency



- Electron cyclotron resonance (ECR) plasma reactor



The collisional re-distribution of the ECRH-driven anisotropy in E_{\perp} causes some parallel momentum to flow from e^{-} to ions



- Coulomb collisions are more efficient at lower energies.

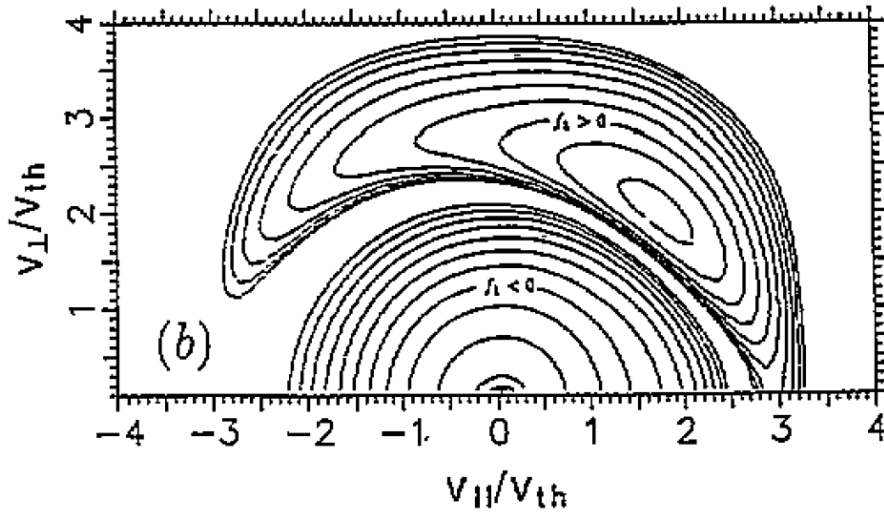

- Electron cyclotron current drive:

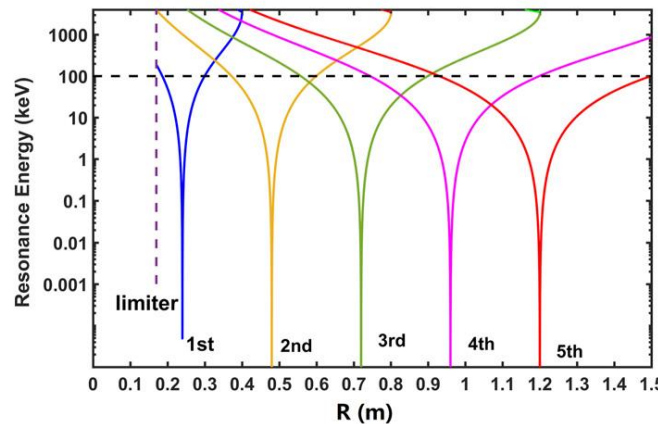

Velocity: $v_2 > v_1$

Collisions: $v_2 < v_1$

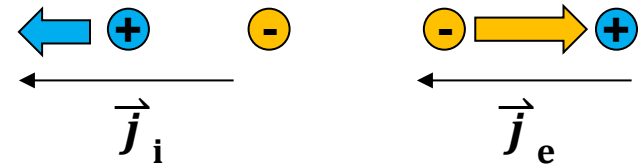

$$\vec{j}_p = -en_e \vec{v}_e + en_i \vec{v}_i$$

$$\vec{P} = n_e m_e \vec{v}_e + n_i m_i \vec{v}_i \approx 0$$

Neutral beam injector is one of the main heat mechanisms in MCF

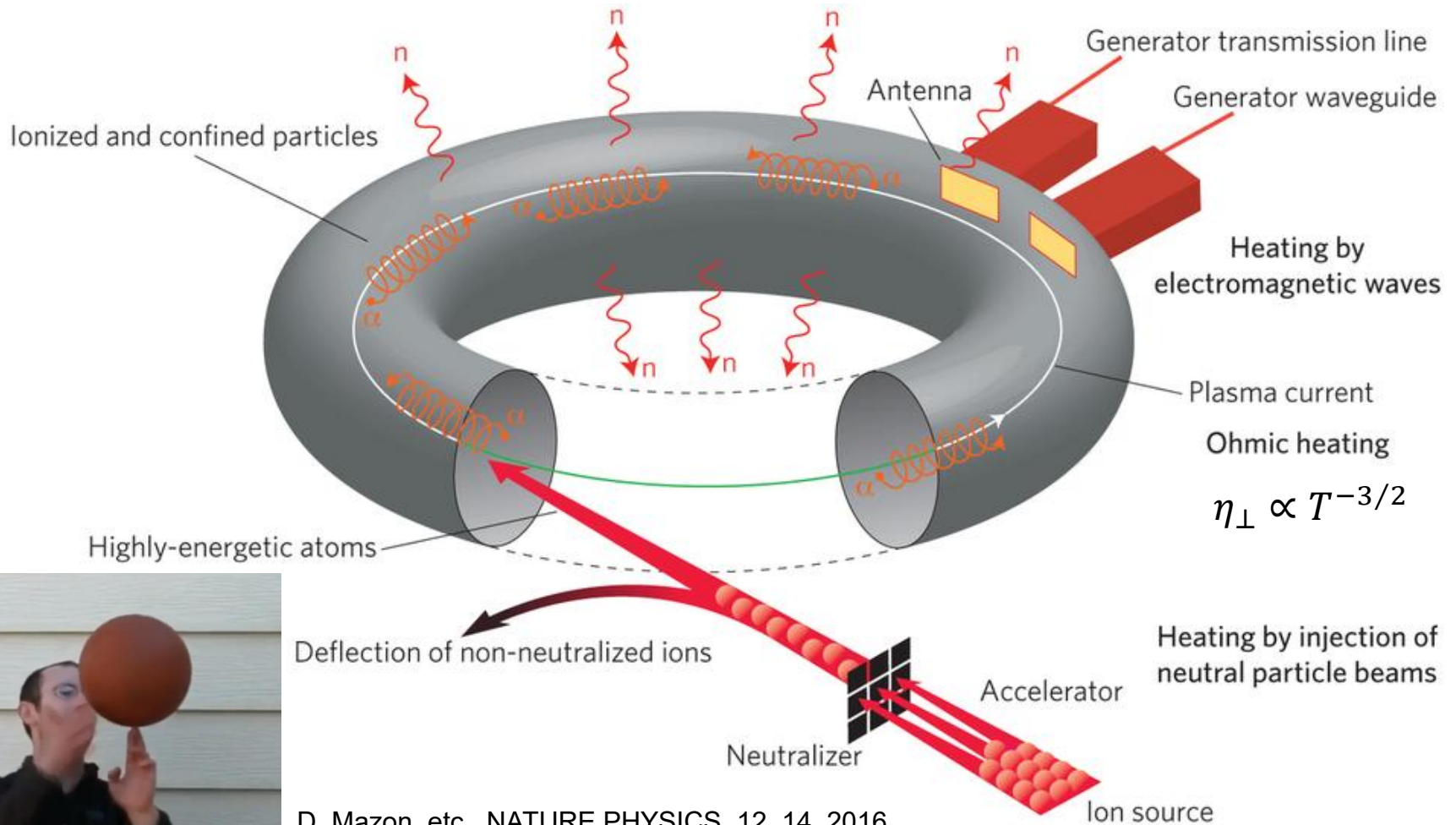

D. Mazon, etc., NATURE PHYSICS, 12, 14, 2016

<https://zh.wikihow.com/%E5%9C%A8%E6%89%8B%E6%8C%87%E4%B8%8A%E8%BD%AC%E7%AF%AE%E7%90%83>

Varies way of heating a MCF device



	System	Frequency/ energy	Maximum power coupled to plasma	Overall system efficiency	Development/ demonstration required	Remarks
ECRF	Demonstrated in tokamaks	28–157 GHz	2.8 MW, 0.2 s	30–40%	Power sources and windows, off-axis CD	Provides off-axis CD
	ITER needs	150–170 GHz	50 MW, SS			
ICRF	Demonstrated in tokamaks	25–120 MHz	22 MW, 3 s (L-mode); 16.5 MW, 3 s (H-mode)	50–60%	ELM tolerant system	Provides ion heating and smaller ELMs
	ITER needs	40–75 MHz	50 MW, SS			
LHRF	Demonstrated in tokamaks	1.3–8 GHz	2.5 MW, 120 s; 10 MW, 0.5 s	45–55%	Launcher, coupling to H-mode	Provides off-axis CD
	ITER needs	5 GHz	50 MW, SS			
NBI	+ve ion Demonstrated in tokamaks	80–140 keV	40 MW, 2 s; 20 MW, 8 s	35–45%	None	Not applicable
	ITER needs	None	None			
NBI	–ve ion Demonstrated in tokamaks	0.35 MeV	5.2 MW, D [–] , 0.8 s (from 2 sources)	~37%	System, tests on tokamak, plasma CD	provides rotation
	ITER needs	1 MeV	50 MW, SS			

‘SS’ indicates steady state

Neutral atoms are ionized by collisions in the plasma

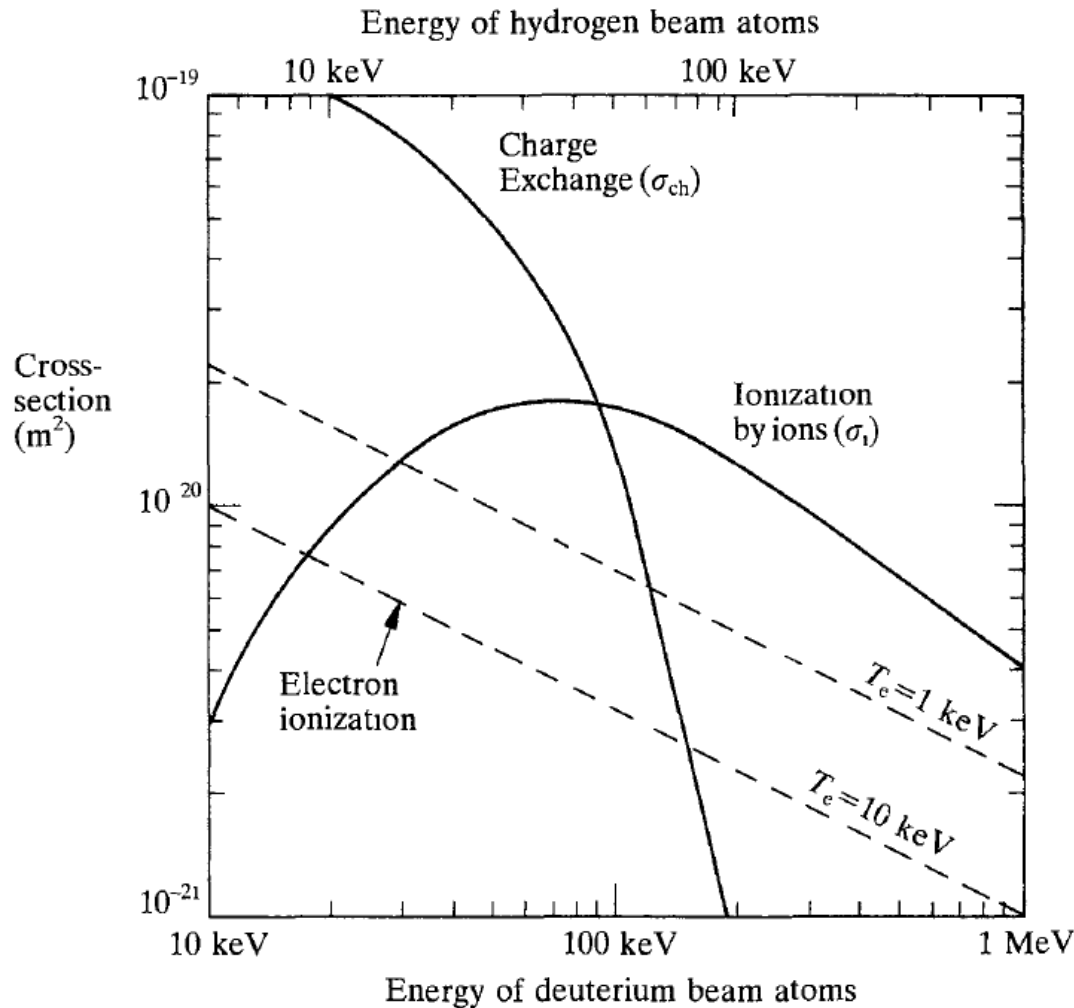

- Charge exchange:

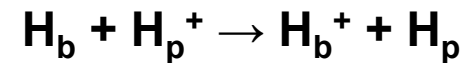

- Ionization by ions



- Ionization by electrons

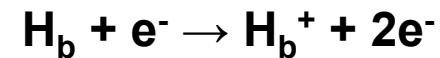

b: beam

p: plasma

Neutral beam absorption length increases with tangential injection



- It is more difficult to access through the toroidal field coils with tangential injection.

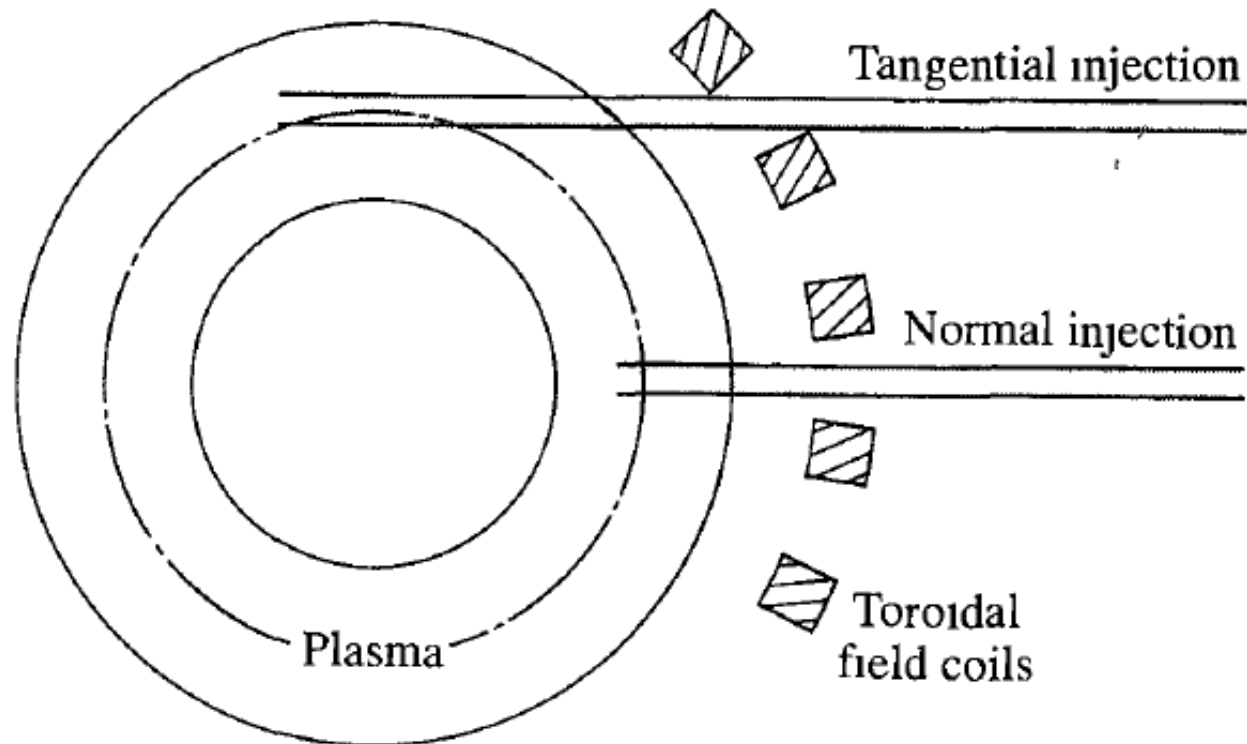

Neutral particles heat the plasma via coulomb collisions

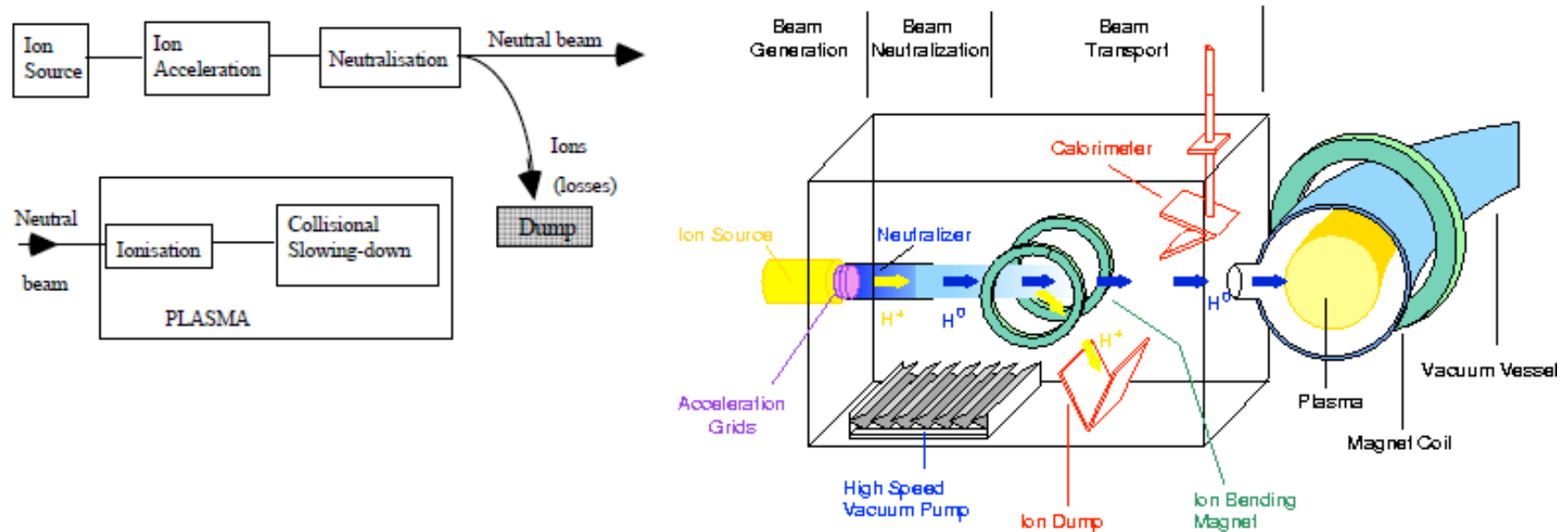

1. create energetic (fast) neutral ions
2. ionize the neutral particles
3. heat the plasma (electrons and ions) via Coulomb collisions

Negative ion source is preferred due to higher neutralization efficiency

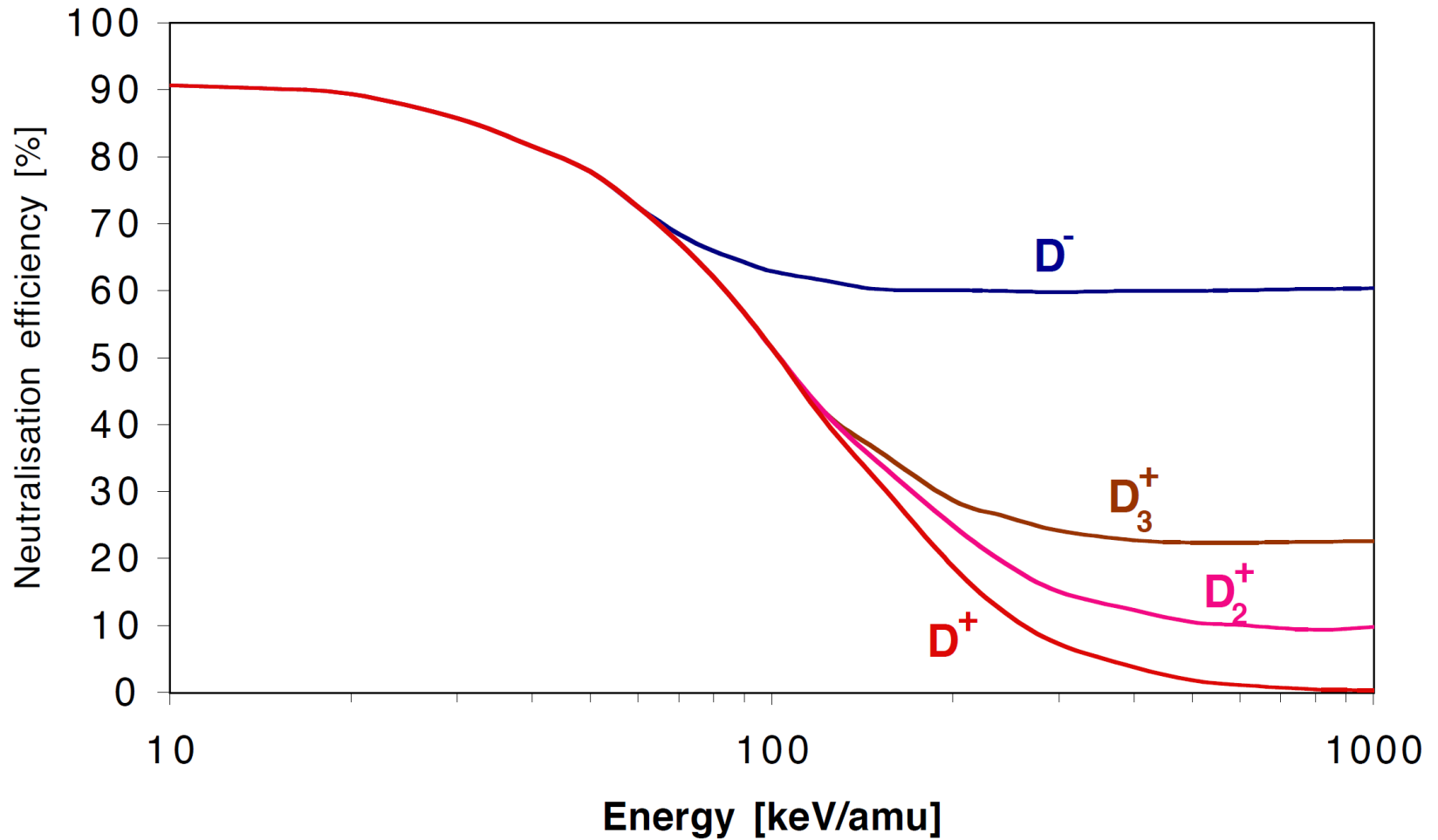

There are two ways to make negative ions – surface and volume production



- **Surface production, depends on :**

- **Work function Φ**
- **Electron affinity level, 0.75 eV for H^-**
- **Perpendicular velocity**
- **Work function can be reduced by covering the metal surface with cesium**

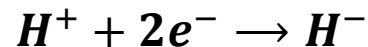
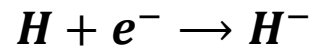
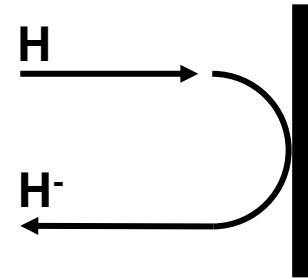

- **Volume production:**

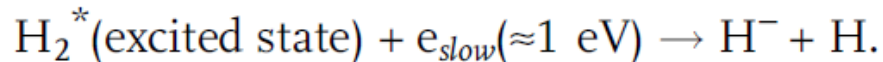
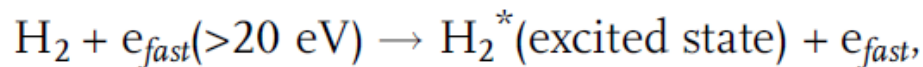

Two-chamber method of negative ions in volume production with a magnetic filter

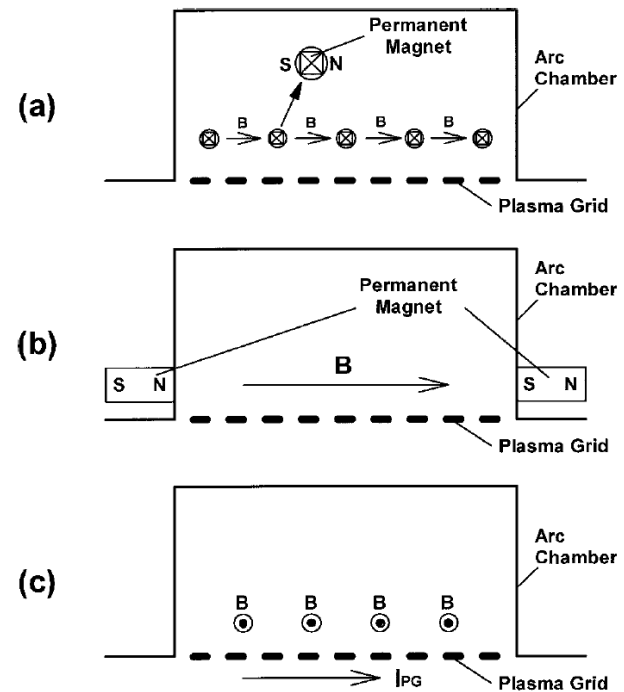
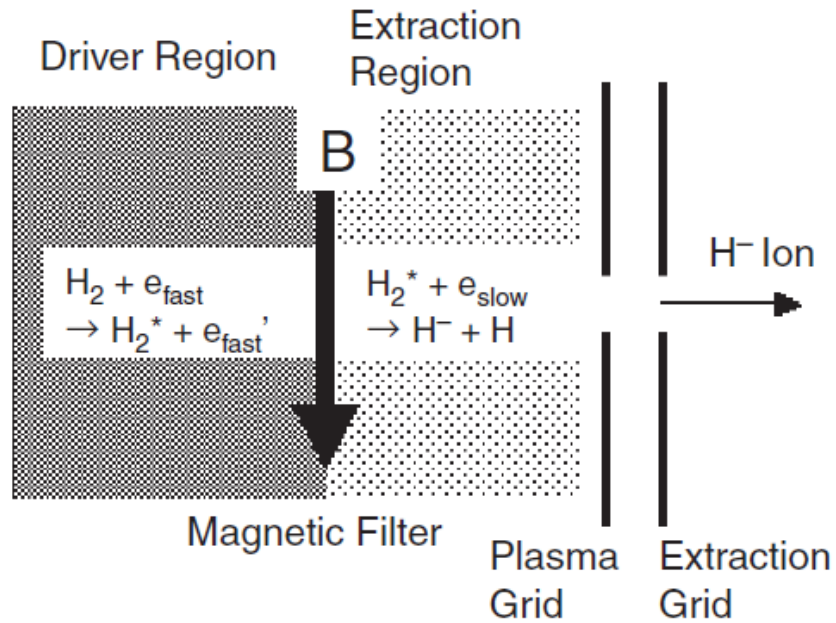

Adding cesium increases negative ion current

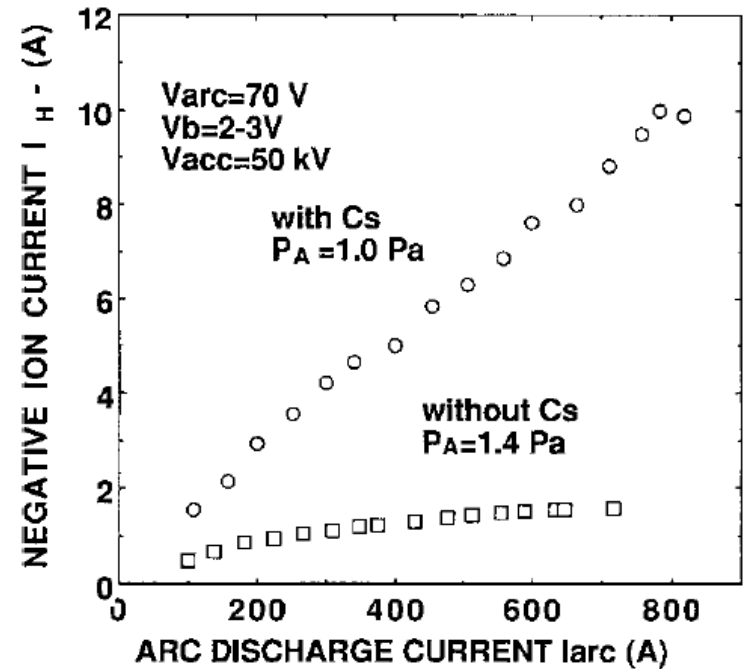
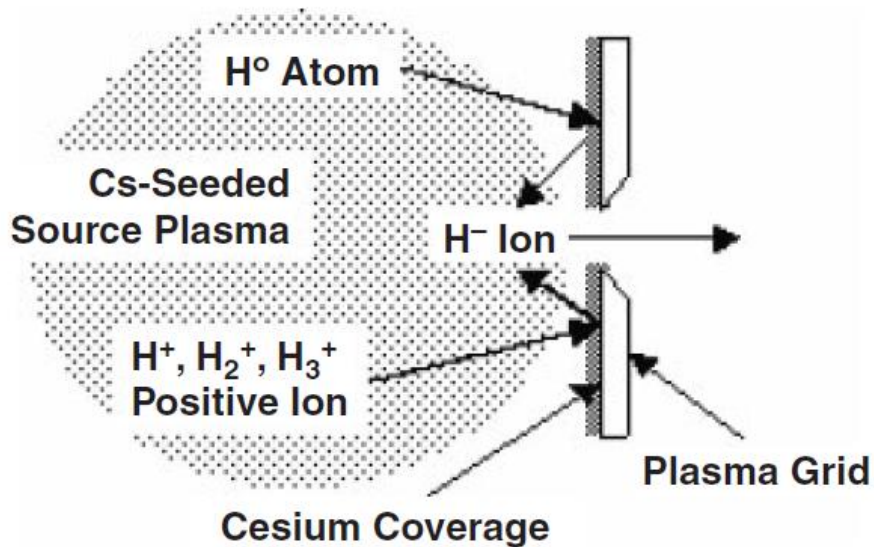

Electrons need to be filtered out since they are extracted together with negative ions

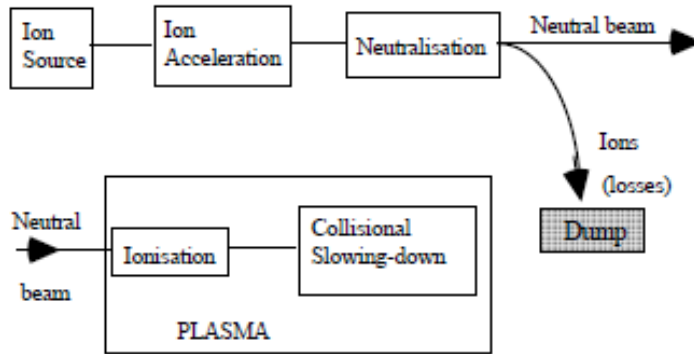

(a)

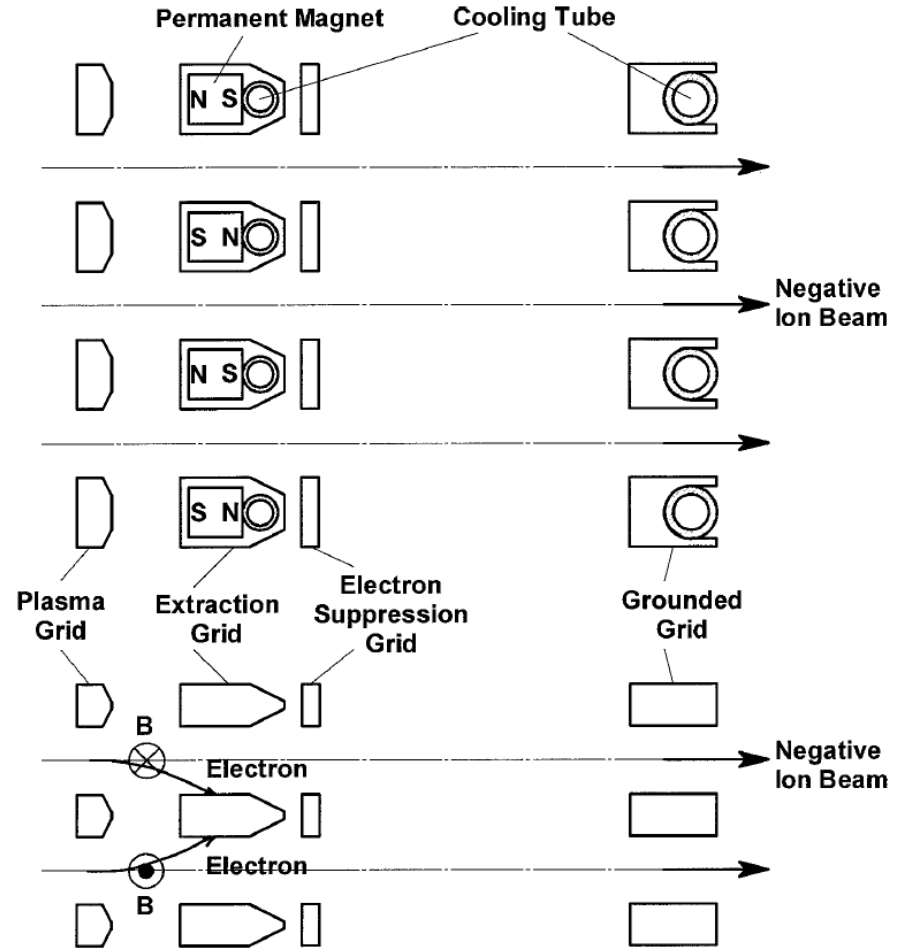

(b)

Acceleration



- Multi-stage acceleration
- Single-stage acceleration

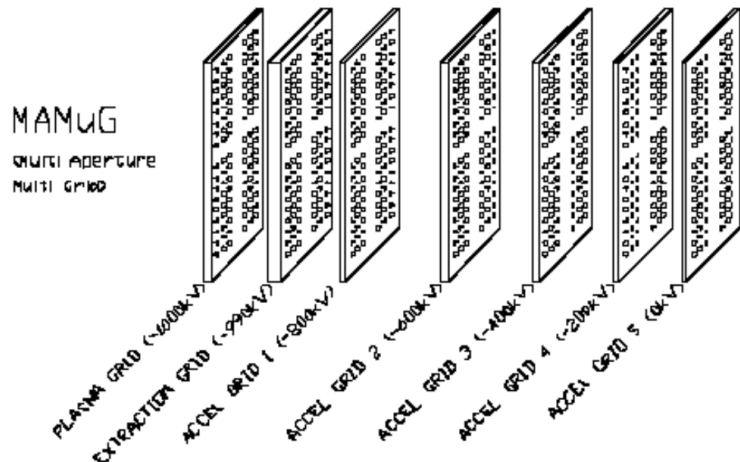
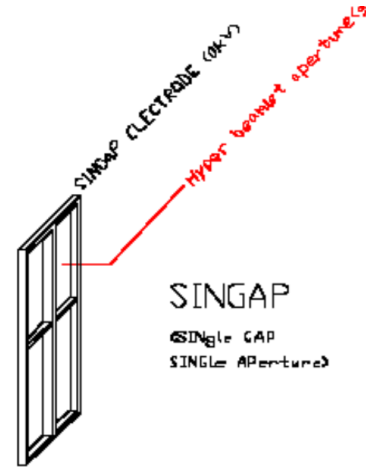
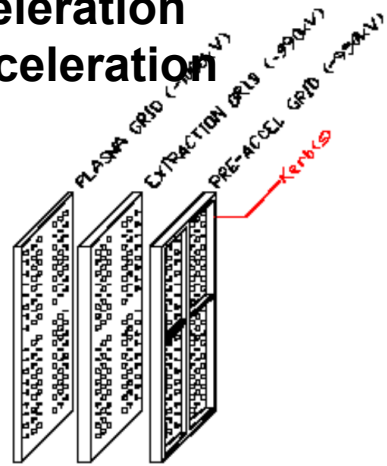

The ITER neutral beam system: status of the project and review of the main technological issues, presented by V. Antoni

NBI system of the LHD fusion machine

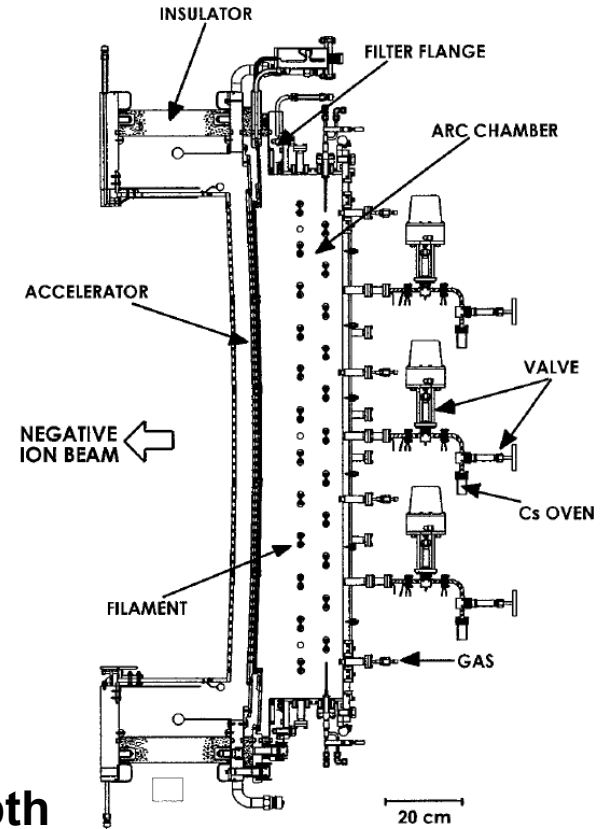
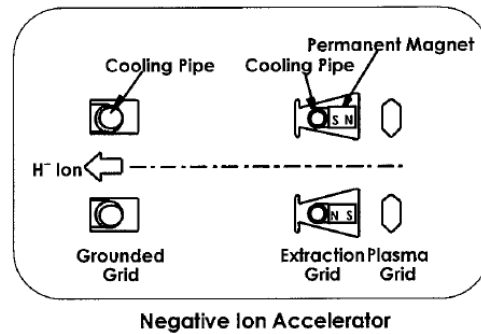

- 180 keV and 30 A
- Arc chamber: 35 cm x 145 cm, 21cm in depth
- Single stage accelerator

JT60U NBI system



- JT-60 (Japan-Torus) is a tokamak in Japan.
- 550 keV, 22A
- 2m in diameter and 1.7 m in height
- 3-stage accelerator

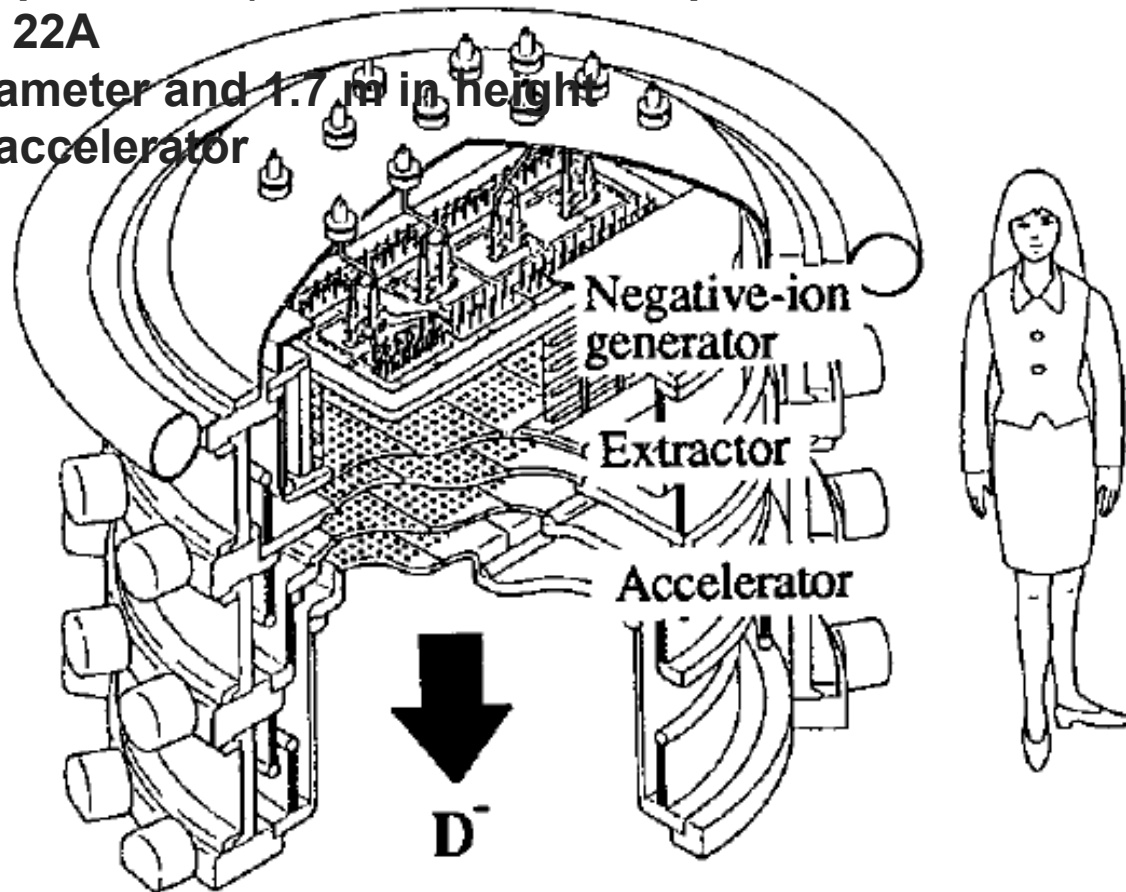

Neutralization



- **Gas neutralization**

- **Collisions between fast negative ions and atoms**

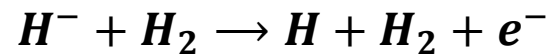

- **Fast ions can lose another electron after neutralized**



- **Plasma neutralization**

- **Collisions with charged particles in plasma**



- **The efficiencies reach up to 85% for fully ionized hydrogen plasma**

Beam dump

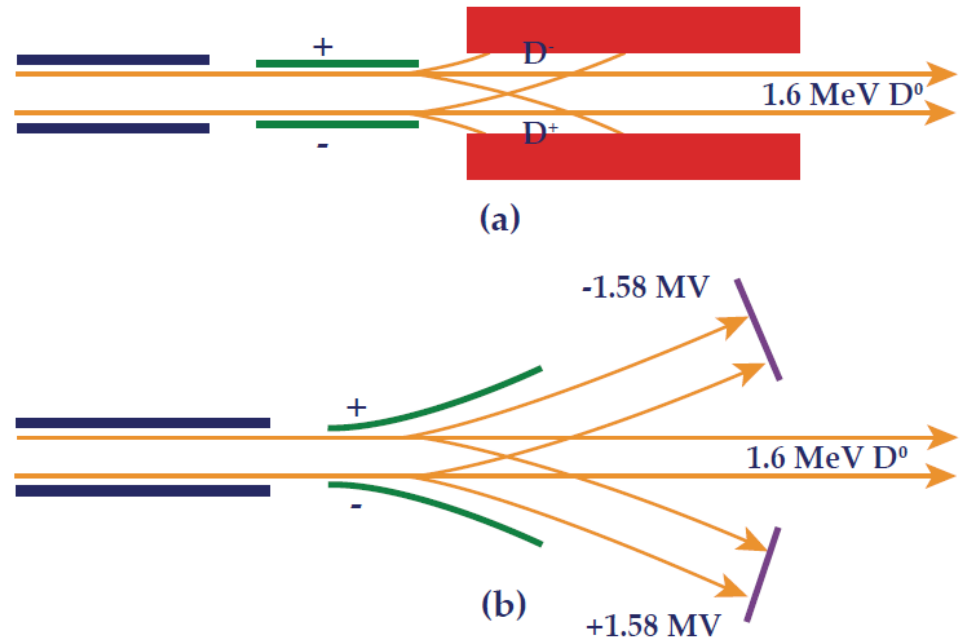
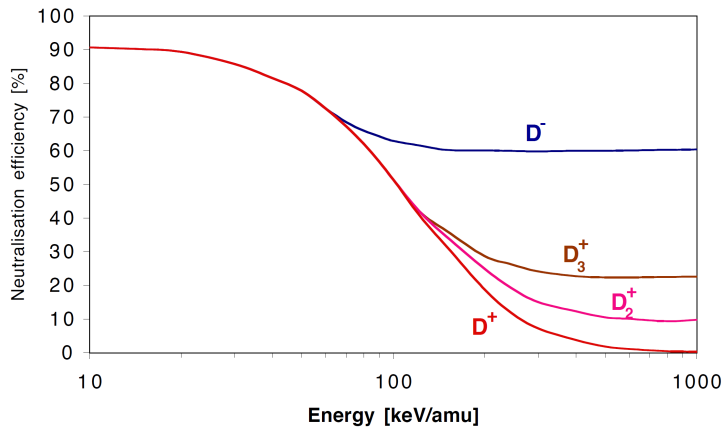

NBI for ITER



- beam components (Ion Source, Accelerator, Neutralizer, Residual Ion Dump and Calorimeter)
- other components (cryo-pump, vessels, fast shutter, duct, magnetic shielding, and residual magnetic field compensating coils)

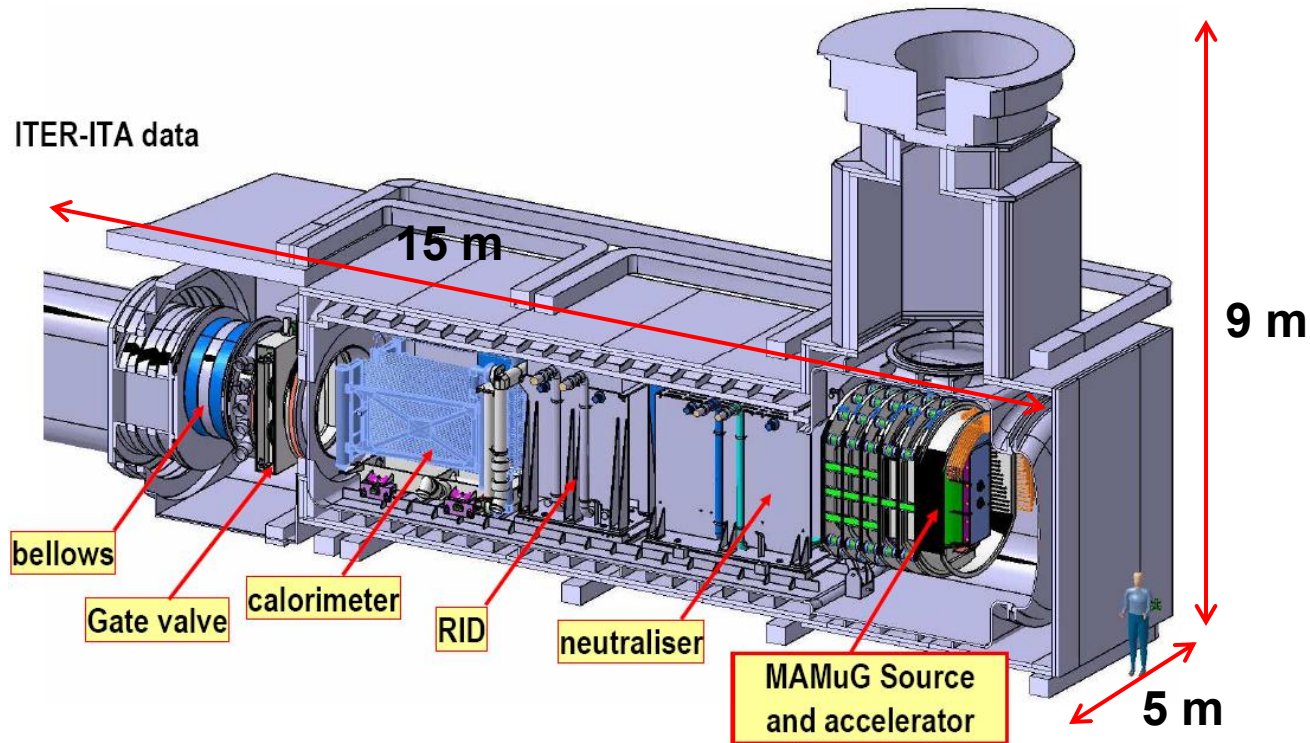

The ITER neutral beam system: status of the project and review of the main technological issues, presented by V. Antoni

Neutral beam penetration

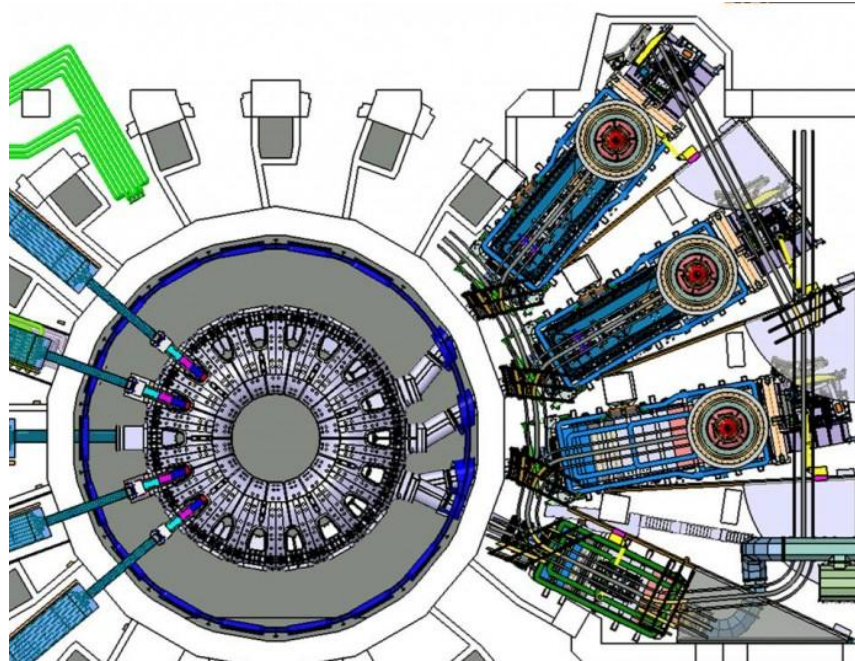

- **Parallel direction**
 - Longest path through the densest part of the plasma
 - Harder to be built
- **Perpendicular direction**
 - Path is short
 - Larger perpendicular energies leads to larger losses
 - Easier to be built

Temperature of 100 eV is the threshold of radiation barrier by impurities

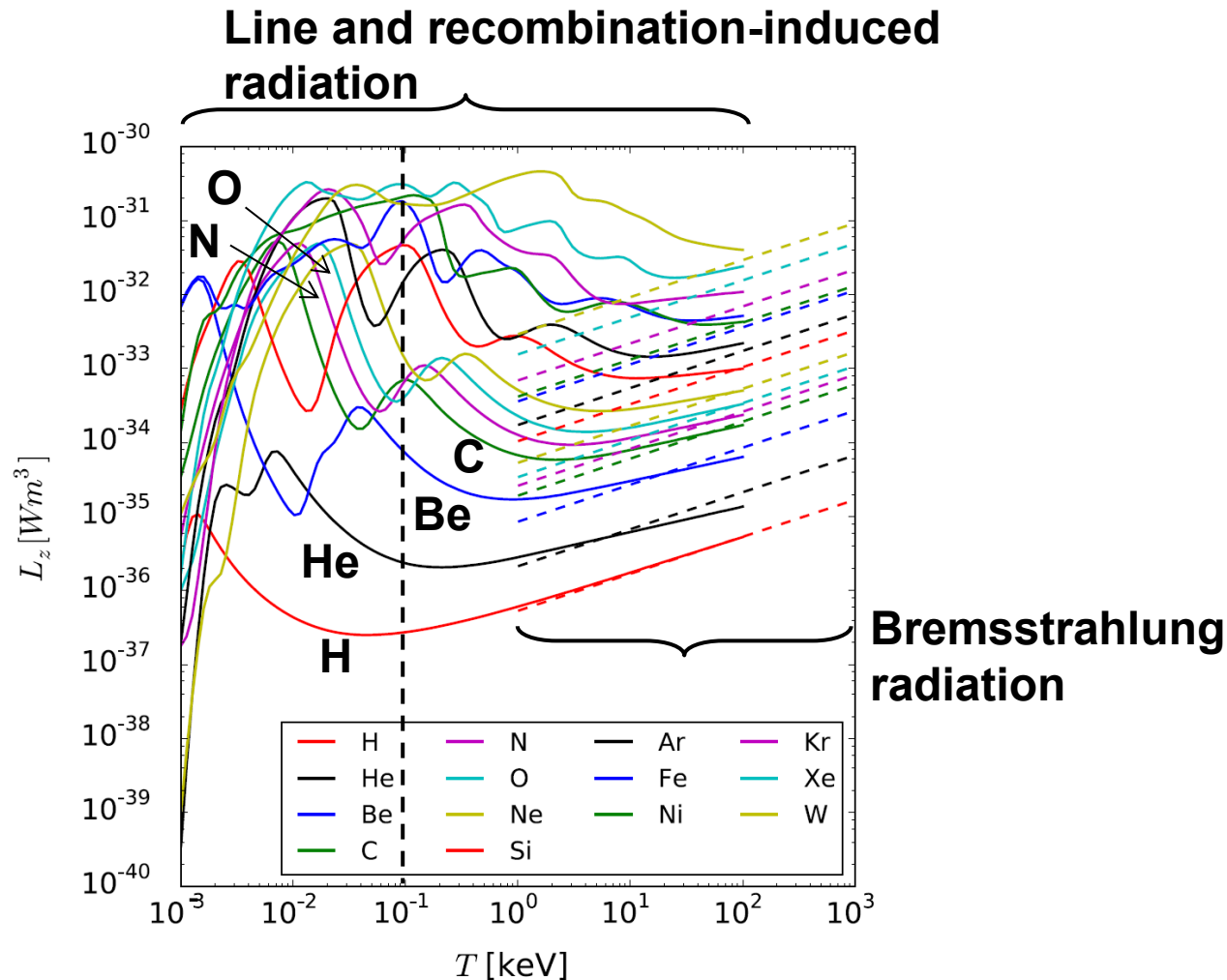

Course Outline



- **Inertial confinement fusion (ICF)**
 - **Plasma frequency and critical density**
 - **Direct- and indirect- drive**
 - **Laser generated pressure (Inverse bremsstrahlung and Ablation pressure)**
 - **Burning fraction, why compressing a capsule?**
 - **Implosion dynamics**
 - **Shock (Compression with different adiabat)**
 - **Laser pulse shape**
 - **Rocket model, shell velocity**
 - **Laser-plasma interaction (Stimulated Raman Scattering, SRS; Stimulated Brillouin Scattering, SBS; Two-plasmon decay)**
 - **Instabilities (Rayleigh-taylor instability, Kelvin-Helmholtz instability, Richtmeyer-Meshkov instability)**

Under what conditions the plasma keeps itself hot?



- **Steady state 0-D power balance:**

$$S_{\alpha} + S_h = S_B + S_k$$

S_{α} : α particle heating

S_h : external heating

S_B : Bremsstrahlung radiation

S_k : heat conduction lost

Ignition condition: $P\tau > 10 \text{ atm-s} = 10 \text{ Gbar} \cdot \text{ns}$

- **P: pressure, or called energy density**
- **τ is confinement time**

Significant breakthrough was achieved in ICF recently



- Inertial confinement fusion (ICF)

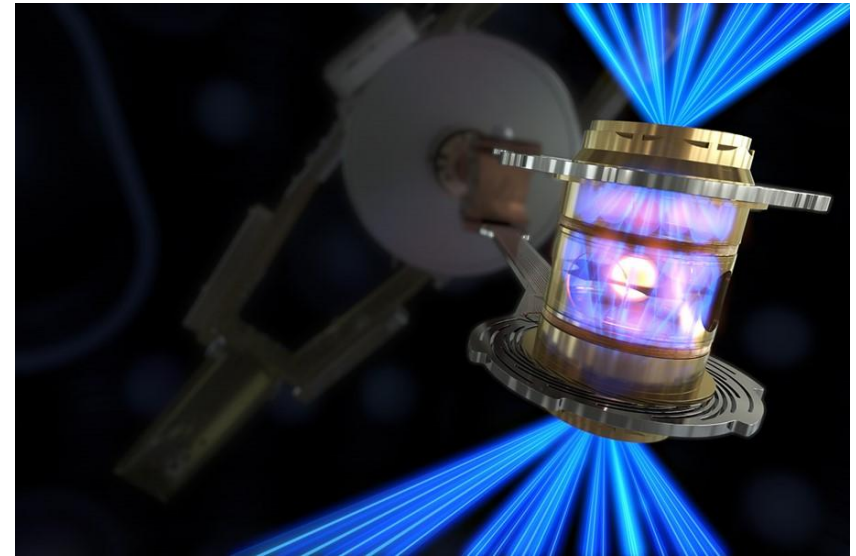
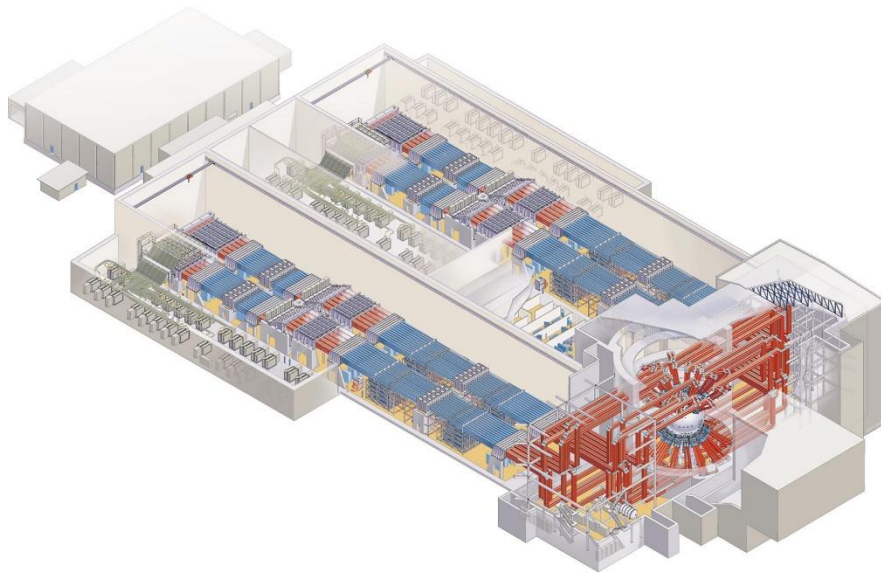

- **National Ignition Facility (NIF) demonstrated a gain greater than 1 for the first time on 2022/12/5. The yield of 3.15 MJ from the 2.05-MJ input laser energy, i.e., $Q=1.5$.**

<https://zh.wikipedia.org/wiki/國家點火設施>

<https://www.science.org/content/article/historic-explosion-long-sought-fusion-breakthrough>

Don't confine it!



- **Solution 2: Inertial confinement fusion (ICF). Or you can say it is confined by its own inertia: P~Gigabar, τ ~nsec, T~10 keV (10^8 °C)**

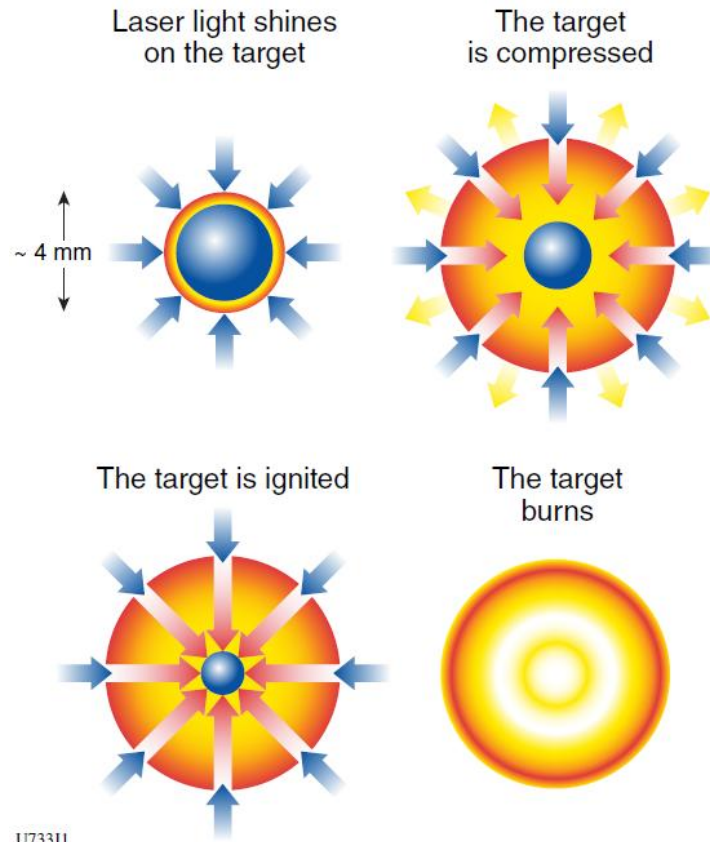

U733J1

Compression happens when outer layer of the target is heated by laser and ablated outward

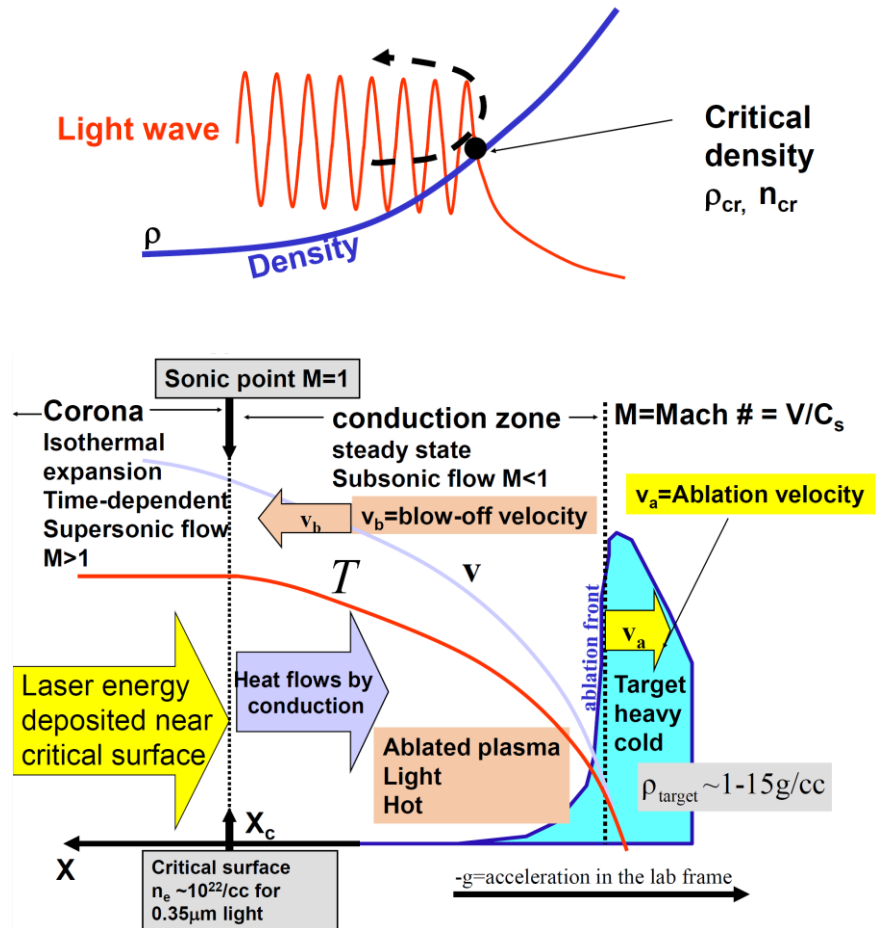
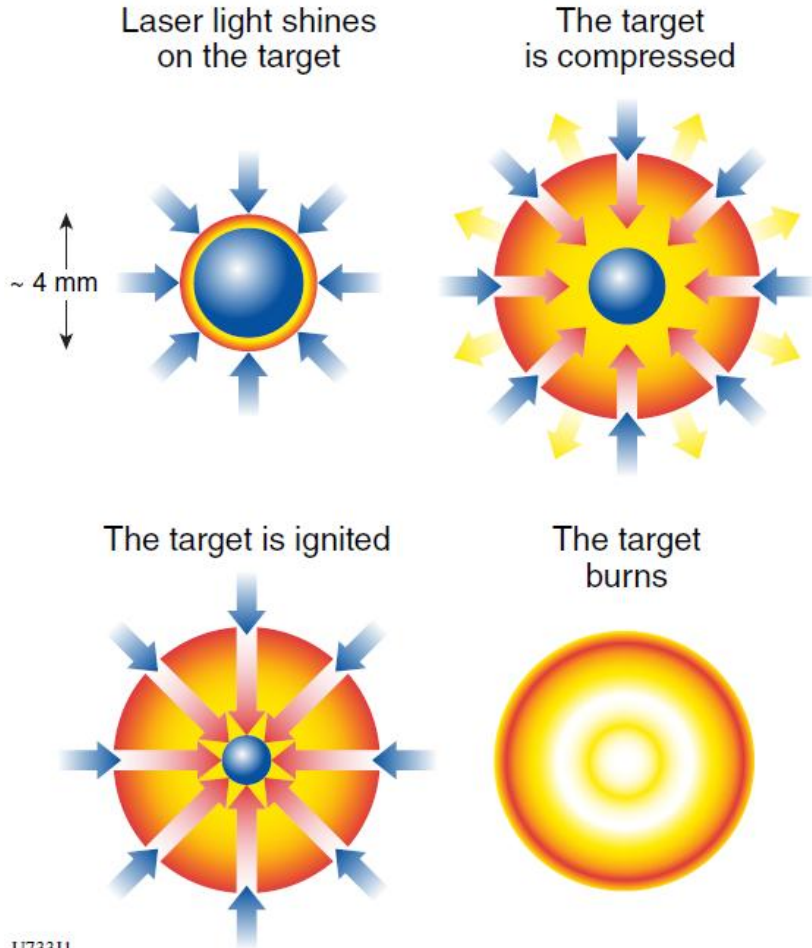

U733J1

Plasma is confined by its own inertia in inertial confinement fusion (ICF)

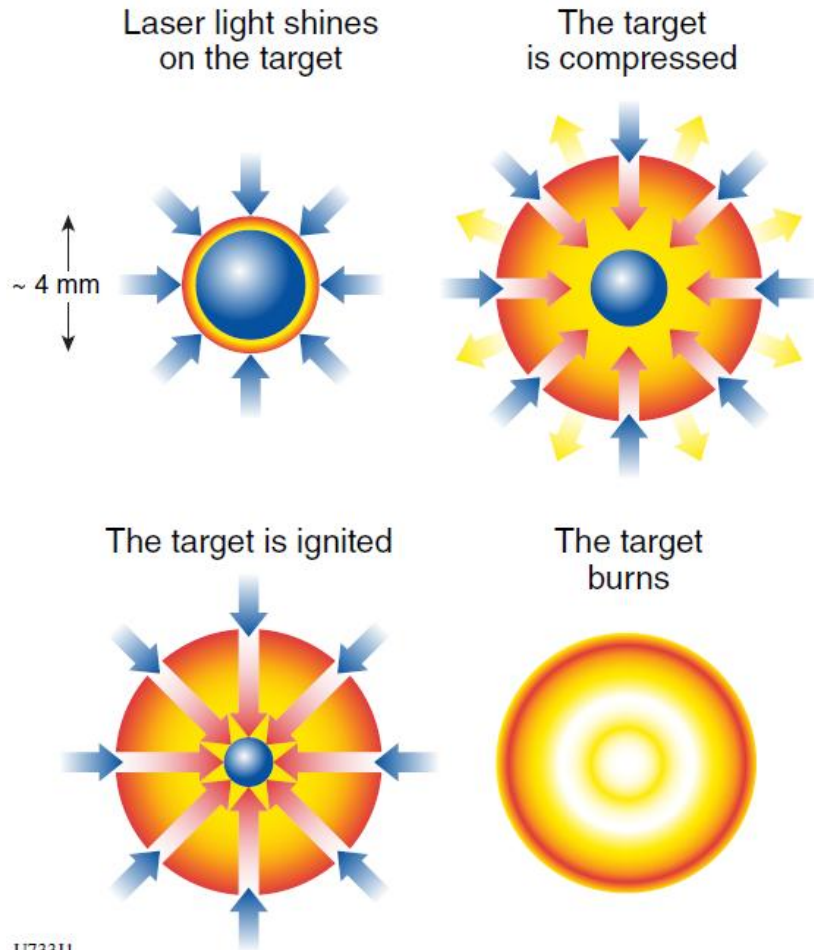

Spatial profile at stagnation

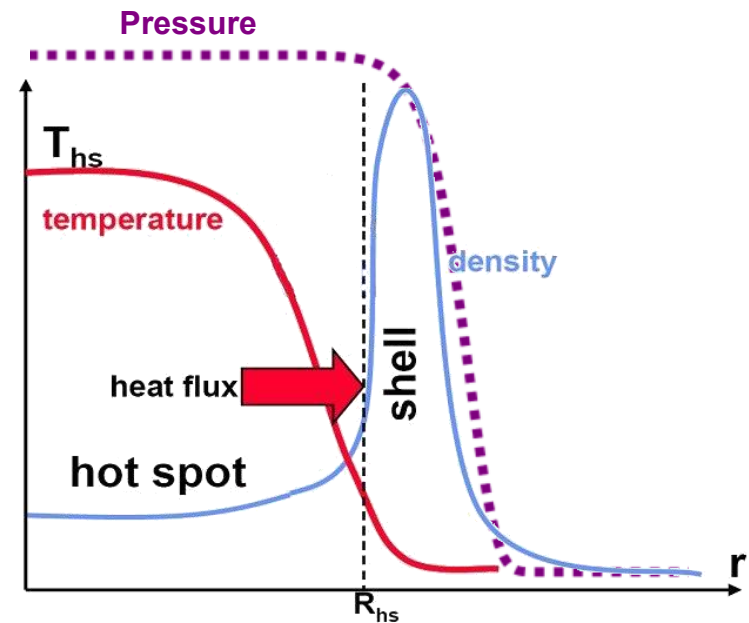

U733J1

A ball can not be compressed uniformly by being squeezed between several fingers



• Rayleigh-Taylor instability

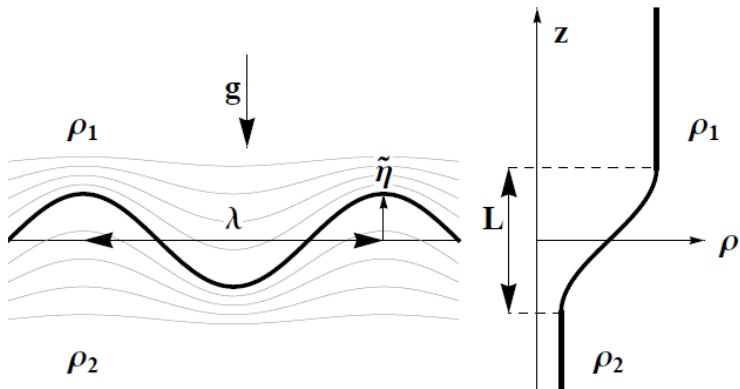

• Stages of a target implosion

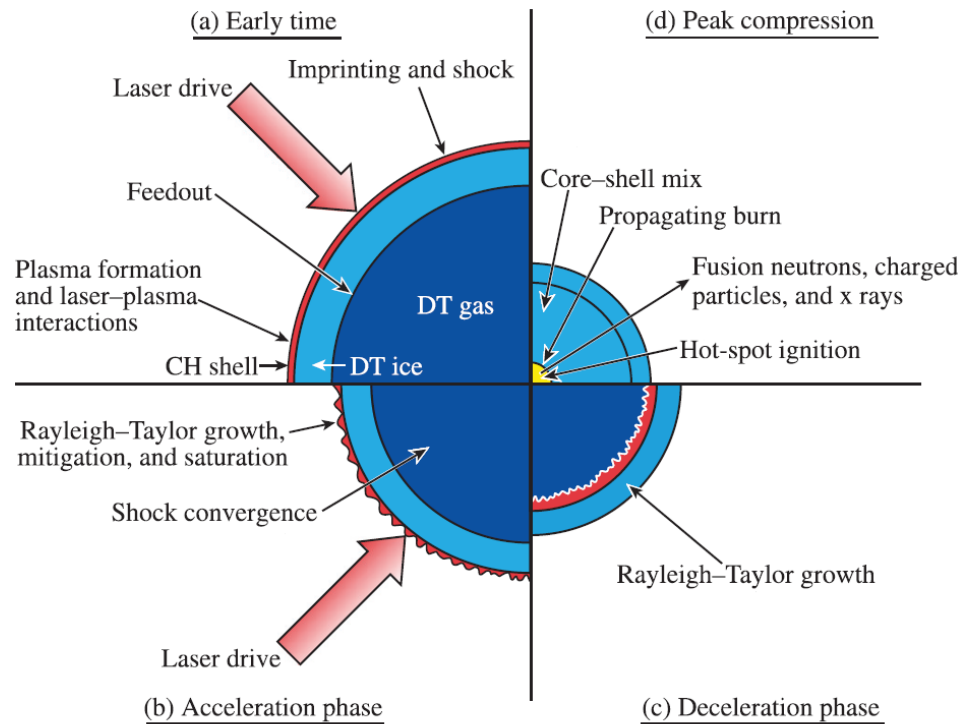

E9886J1

A spherical capsule can be imploded through directly or indirectly laser illumination



Direct-drive target

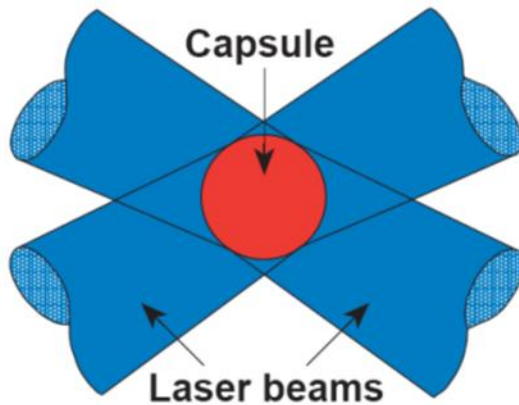

Indirect-drive target

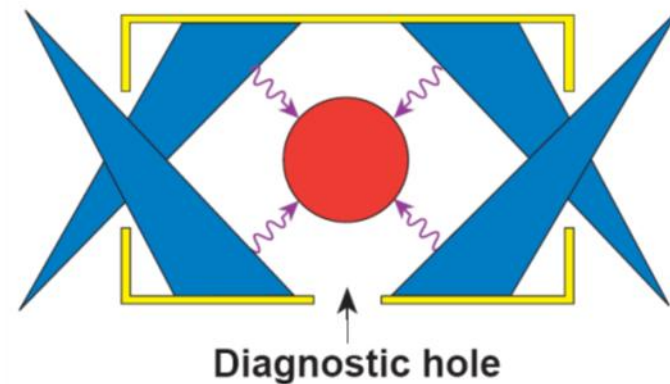

Hohlraum using
a cylindrical high-Z case

The 1.8-MJ National Ignition Facility (NIF) will demonstrate ICF ignition and modest energy gain

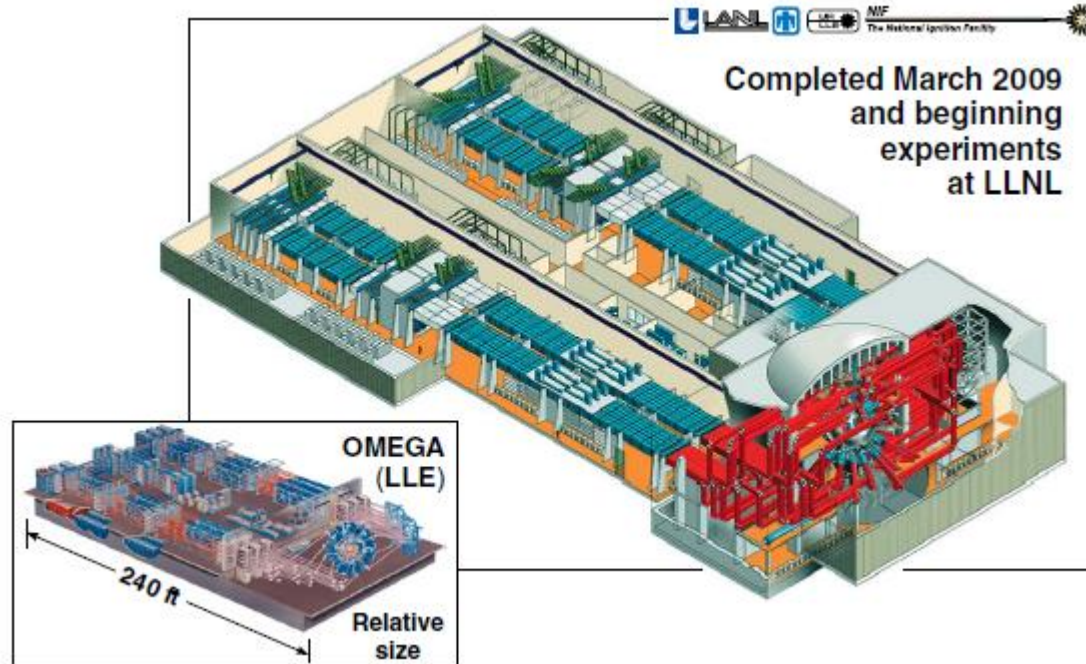

OMEGA experiments are integral to an ignition demonstration on the NIF.

Targets used in ICF

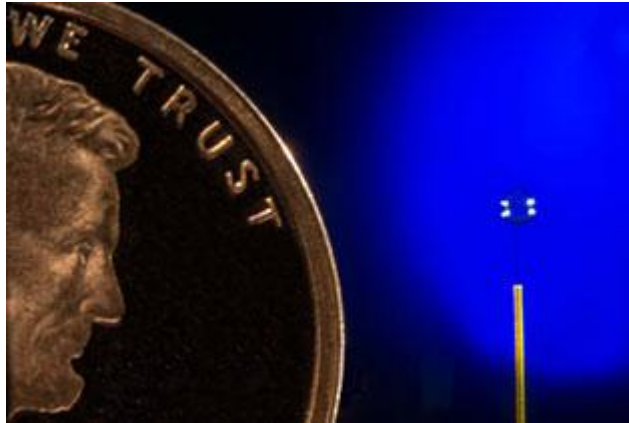

- **Triple-point temperature : 19.79 K**

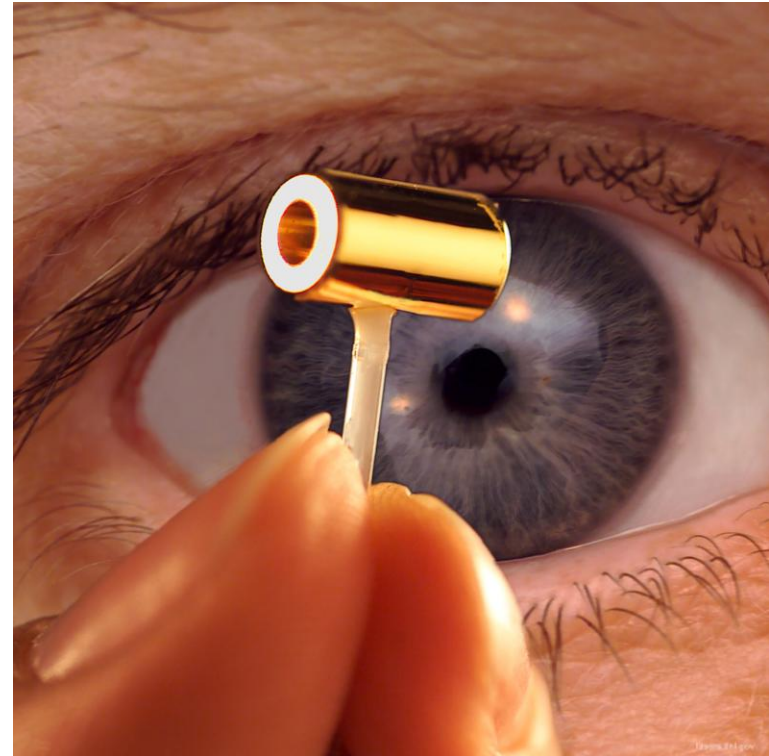
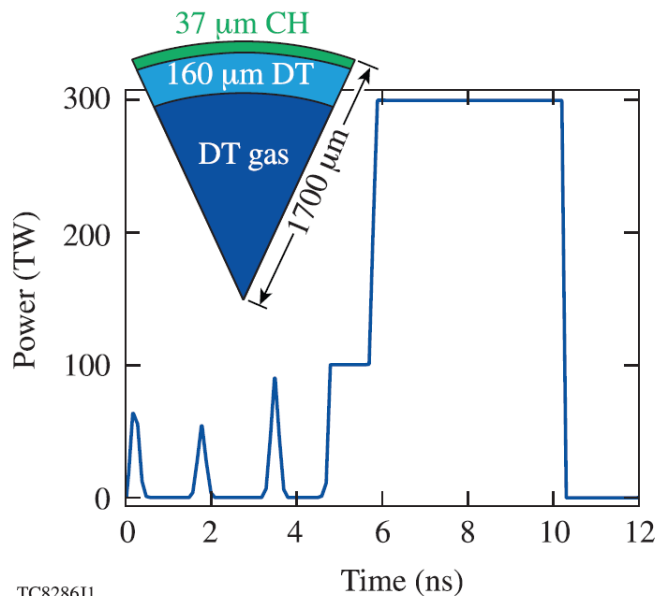

<http://www.lle.rochester.edu>
https://en.wikipedia.org/wiki/Inertial_confinement_fusion
R. S. Craxton, et al., *Phys. Plasmas* **22**, 110501 (2015)

Softer material can be compressed to higher density



- Compression of a baseball



- Compression of a tennis ball



<https://www.youtube.com/watch?v=uxlldMoAwbY>

<https://newsghana.com.gh/wimbledon-slow-motion-video-of-how-a-tennis-ball-turns-to-goo-after-serve/>

A shock is formed due to the increasing sound speed of a compressed gas/plasma



- **Wave in the ocean:**

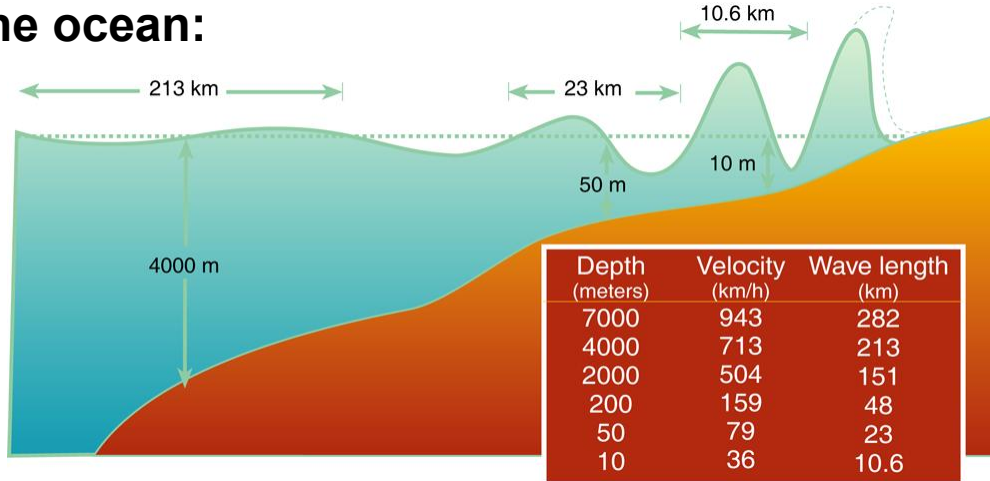

- **Acoustic/compression wave driven by a piston:**

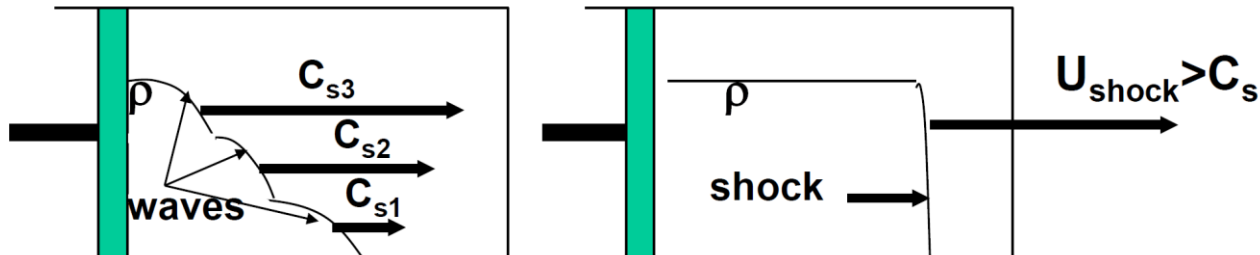

$$C_s \sim \sqrt{\frac{p}{\rho}} \sim \sqrt{\frac{\alpha \rho^{5/3}}{\rho}} \sim \sqrt{\alpha} \rho^{1/3}$$

Targets used in ICF

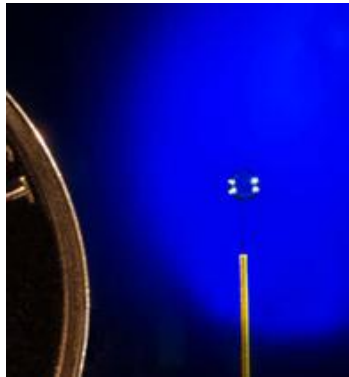

Cryogenic shroud

a Cryogenic hohlraum

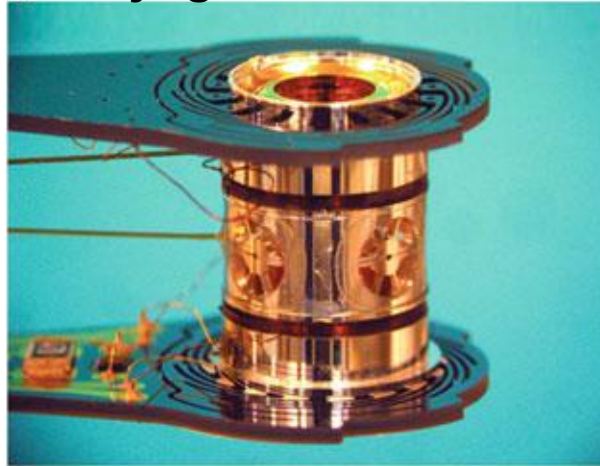

b



c Rugby hohlraum

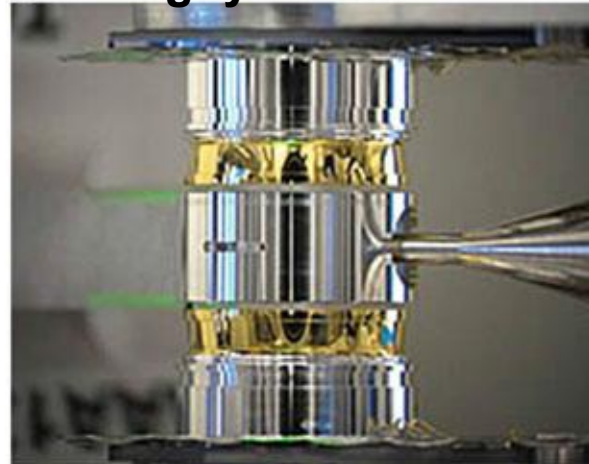

d Tent holder

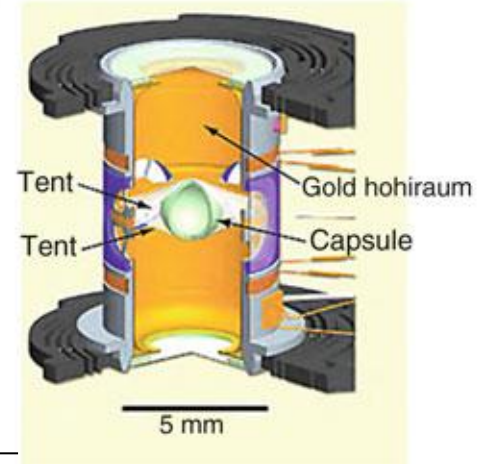

<https://www.lle.rochester.edu/index.php/2014/11/10/next-generation-cryo-target/>
Introduction to Plasma Physics and Controlled Fusion 3rd Edition, by Francis F. Chen
<https://www.llnl.gov/news/nif-shot-lights-way-new-fusion-ignition-phase>

Nature letter “Fuel gain exceeding unity in an inertially confined fusion implosion”

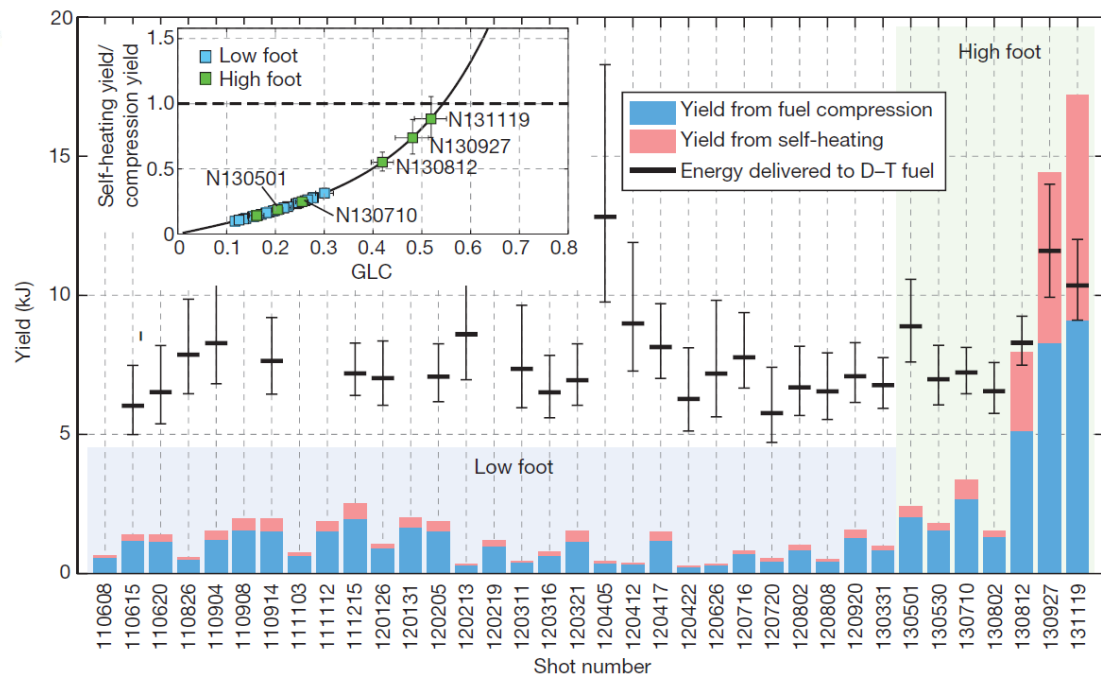
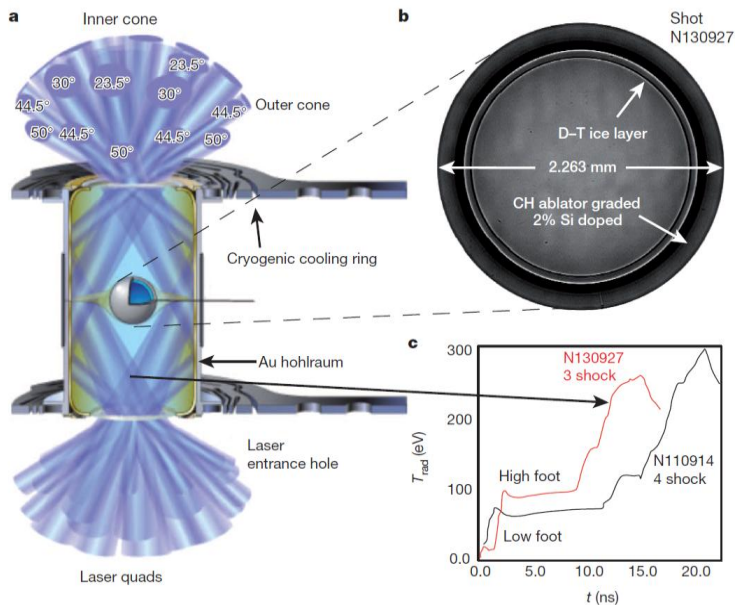

• Fuel gain exceeding unity was demonstrated for the first time.

The hot spot has entered the burning plasma regime

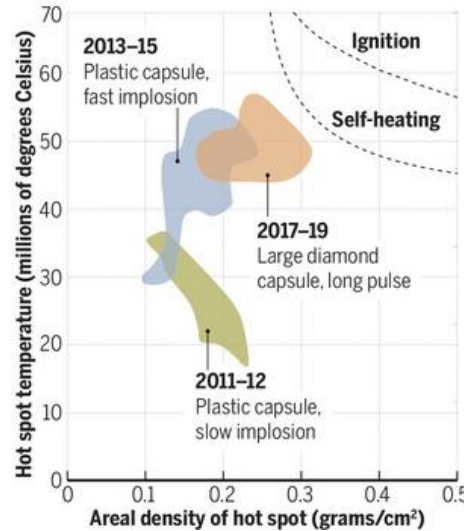
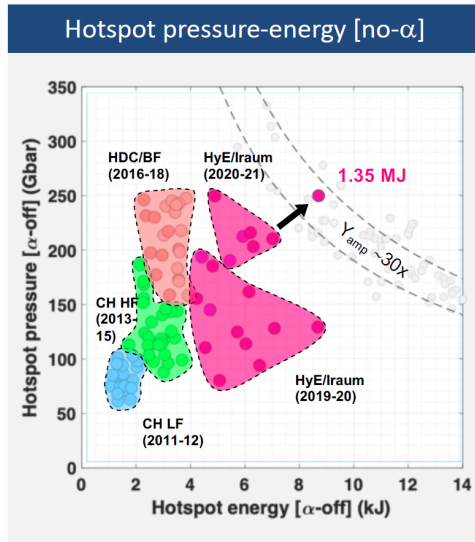

• Hybrid-E

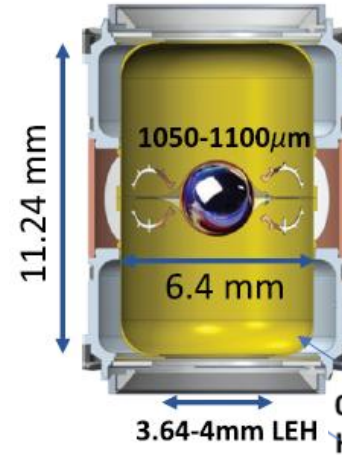

• I-raum

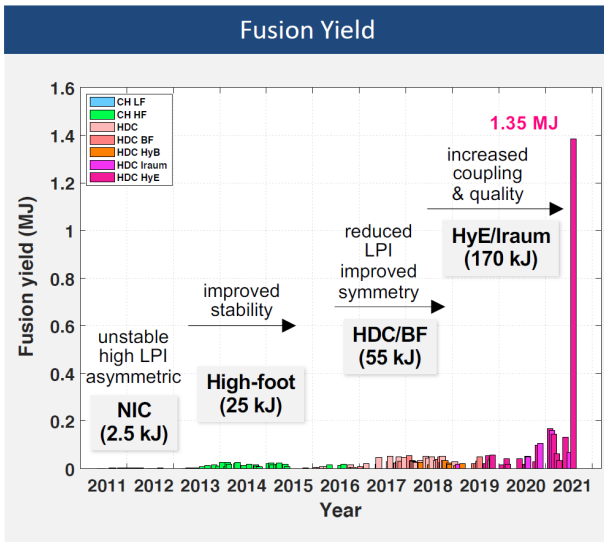
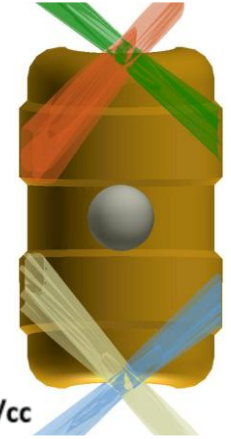

• Big foot

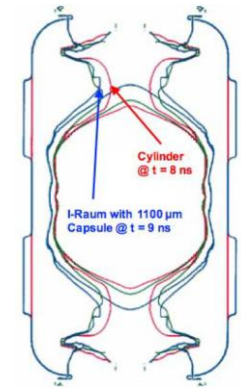
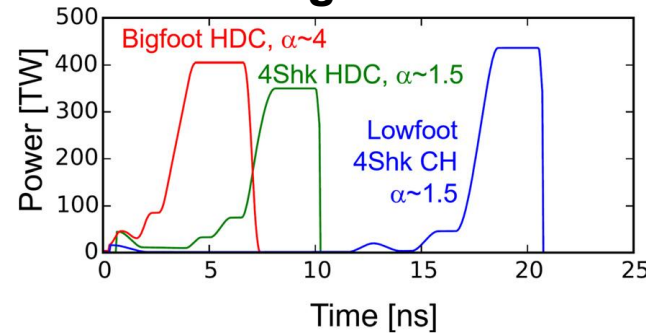

T. Ma, ARPA-E workshop, April 26, 2022

Science 370, p1019, 2020

D. T. Casey, etc., Phys. Plasmas, 25, 056308 (2018)

A. L. Kritcher, etc., Phys. Plasmas, 28, 072706 (2021)

H. F. Robey, etc., Phys. Plasmas, 25, 012711 (2018)

National Ignition Facility (NIF) achieved a yield of more than 1.3 MJ from ~1.9 MJ of laser energy in 2021 (Q~0.7)

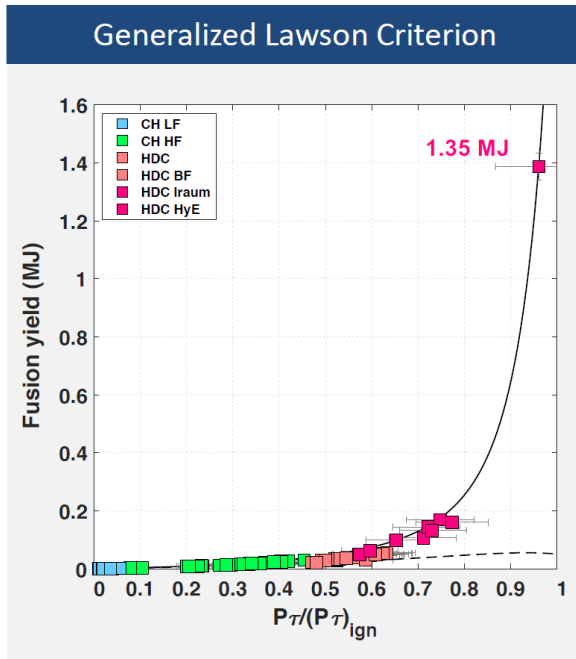

- National Ignition Facility (NIF) achieved a yield of more than 1.3 MJ (Q~0.7). This advancement puts researchers at the threshold of fusion ignition.

THE ROAD TO IGNITION

The National Ignition Facility (NIF) struggled for years before achieving a high-yield fusion reaction (considered ignition, by some measures) in 2021. Repeat experiments, however, produced less than half the energy of that result.

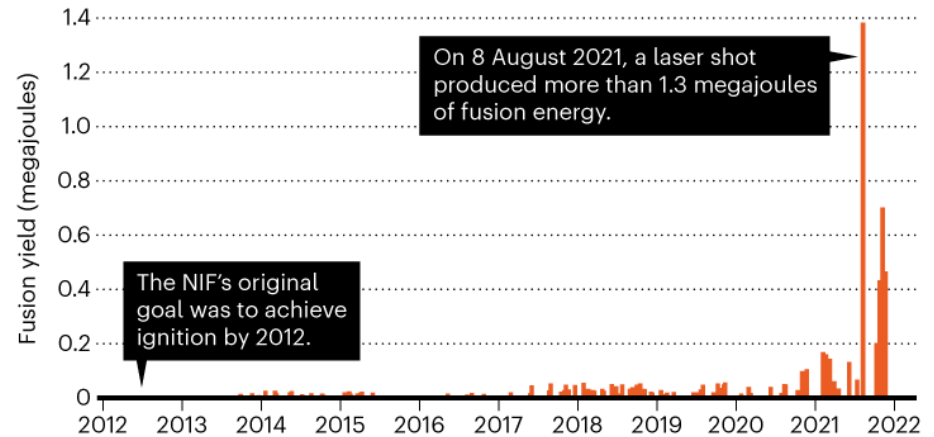

©nature

- Laser-fusion facility heads back to the drawing board.

“Ignition” (target yield larger than one) was achieved in NIF on 2022/12/5

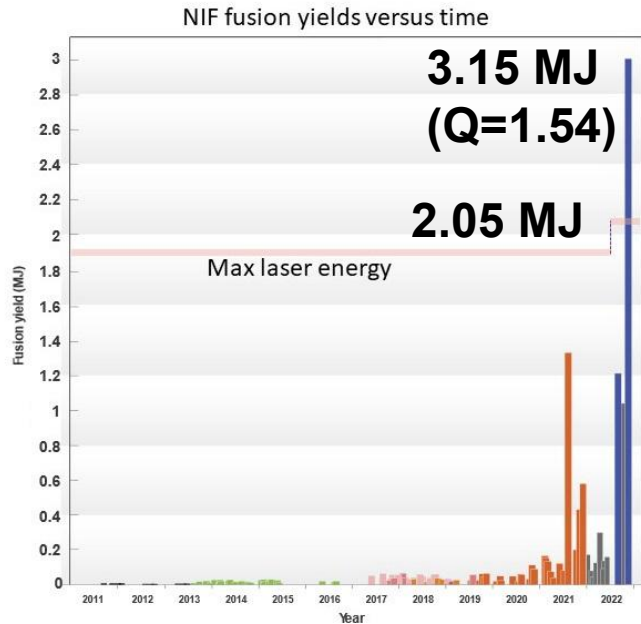

NIF's ignition achievement in perspective

Energy in megajoules ● = 1

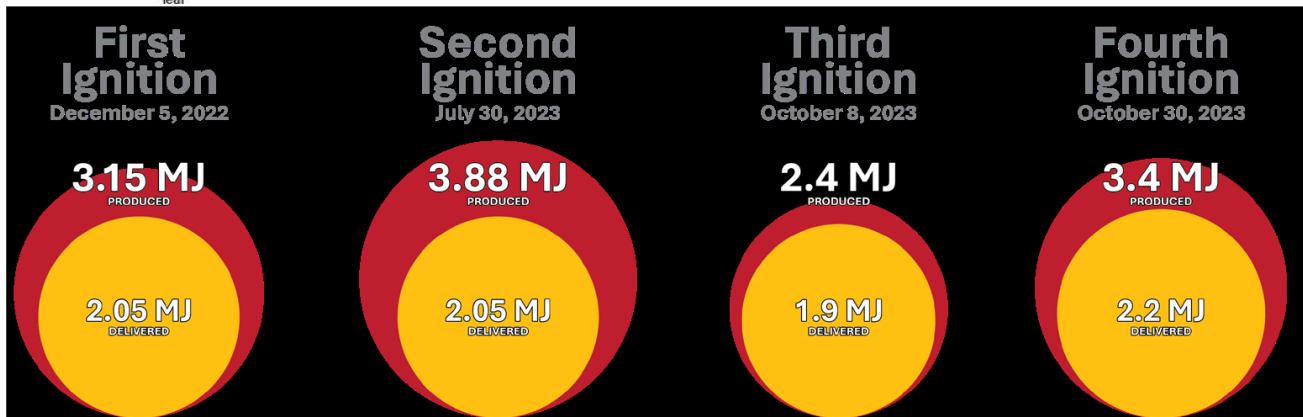
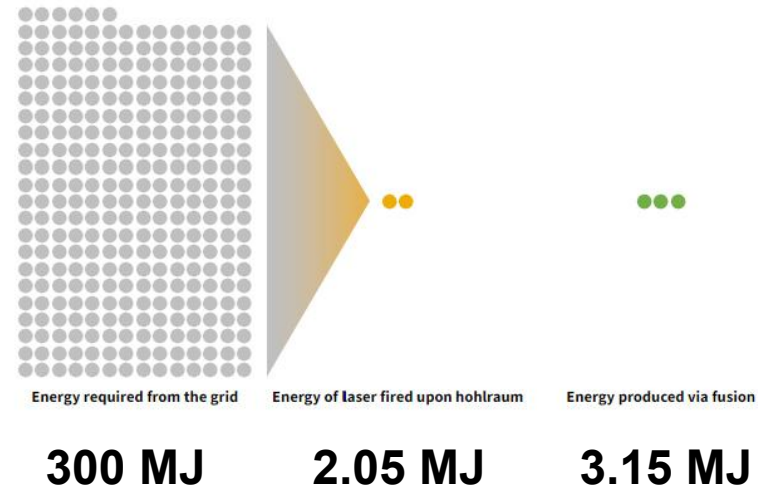

<https://physicstoday.scitation.org/doi/10.1063/PT.6.2.20221213a/full/>
The age of ignition: anniversary edition, LLNL-BR-857901

External “spark” can be used for ignition



- Shock ignition

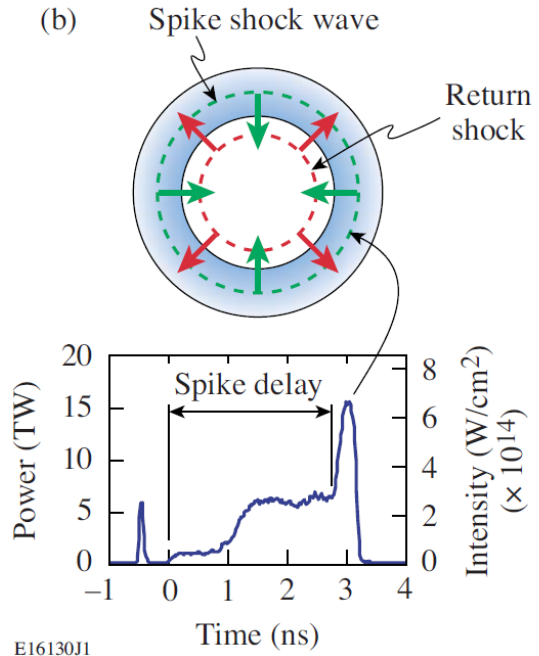
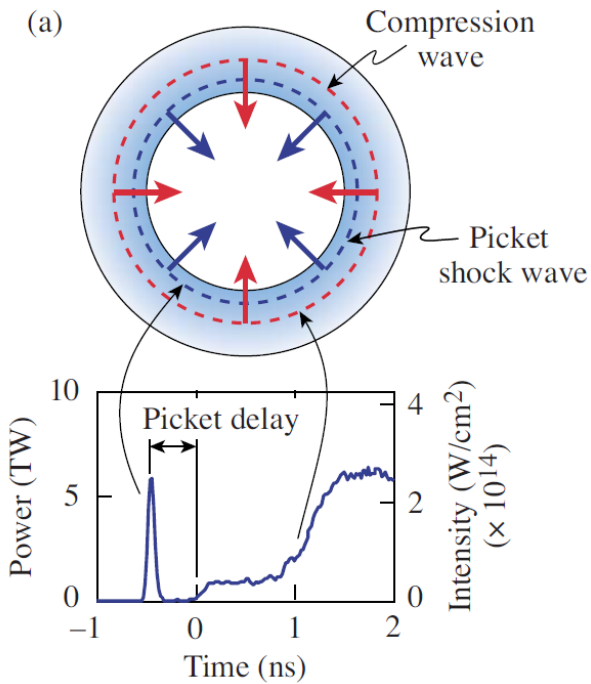

E16130J1

- Fast ignition

- a) channeling FI concept

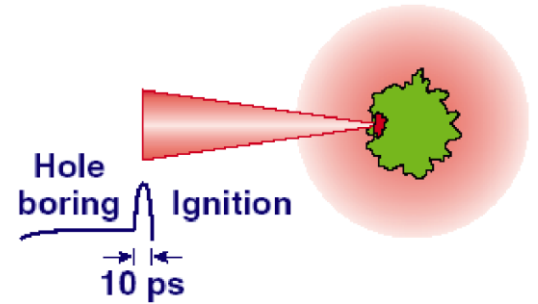

- b) cone-in-shell FI concept

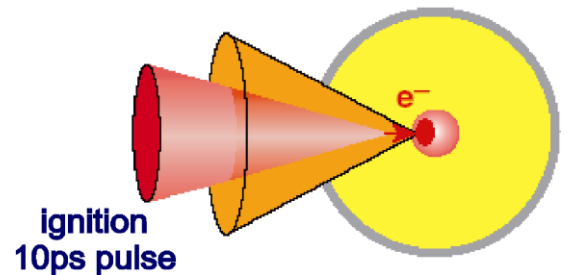

External “spark” can be used for ignition



- Shock ignition

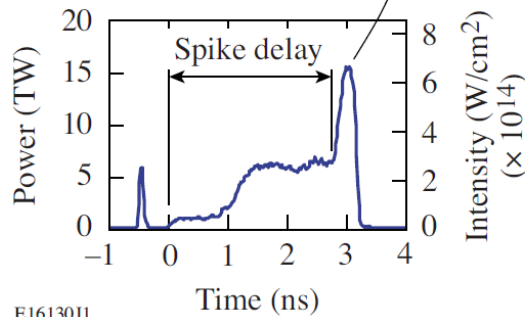
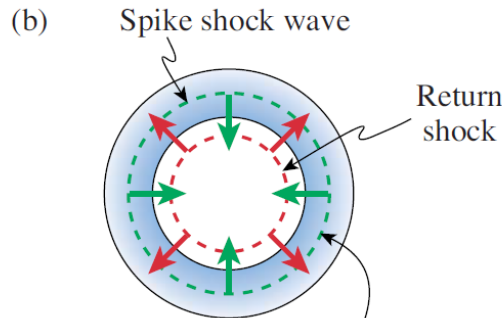
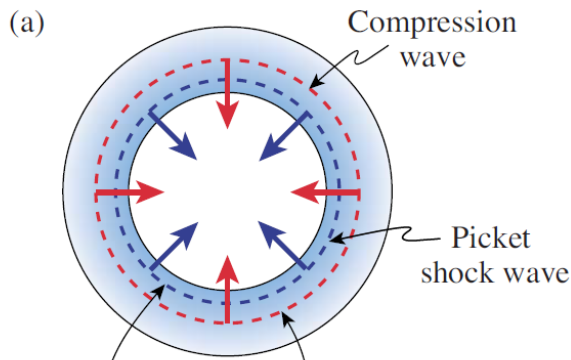

E16130J1

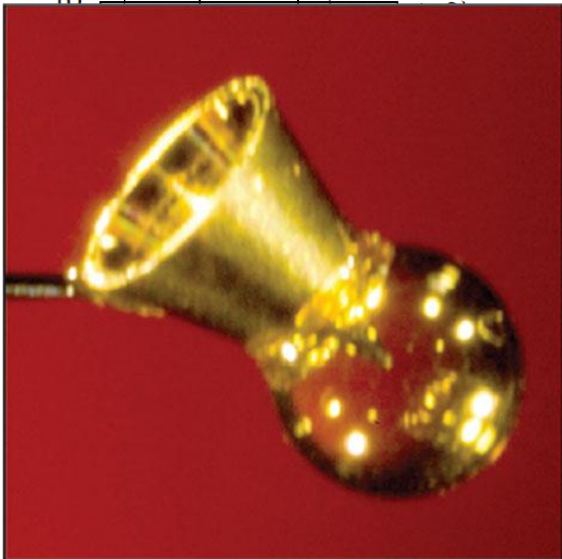

- Fast ignition

- a) channeling FI concept

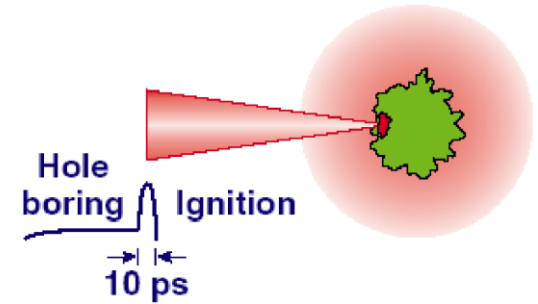

- b) cone-in-shell FI concept

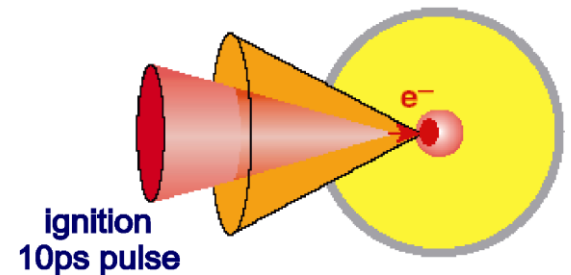

J. Badziak, Bull.Polish Acad. Sci. Tech. Sci.Phys. Plasmas 15, 056306 (2008)
 T. Ditmire, etc., J. Fusion Energy 42, 27 (2023)

A shock is formed due to the increasing sound speed of a compressed gas/plasma



- **Wave in the ocean:**

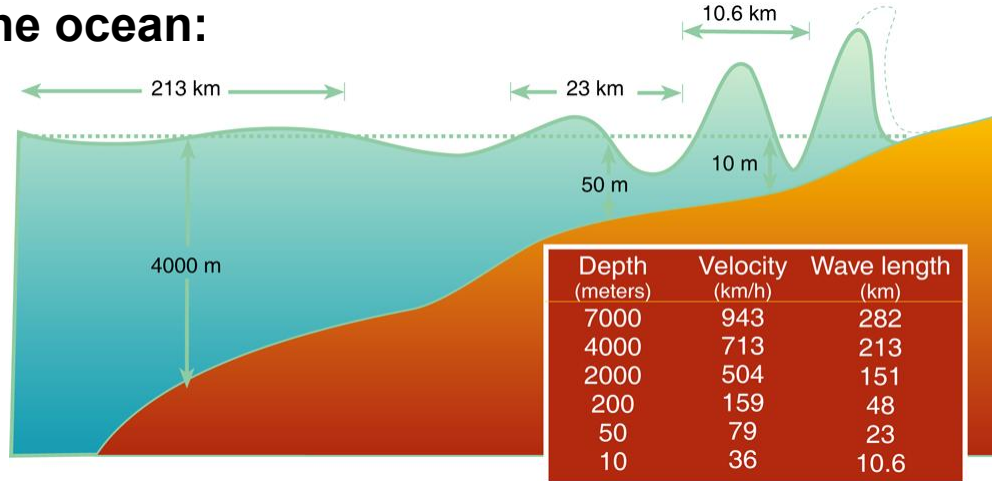

- **Acoustic/compression wave driven by a piston:**

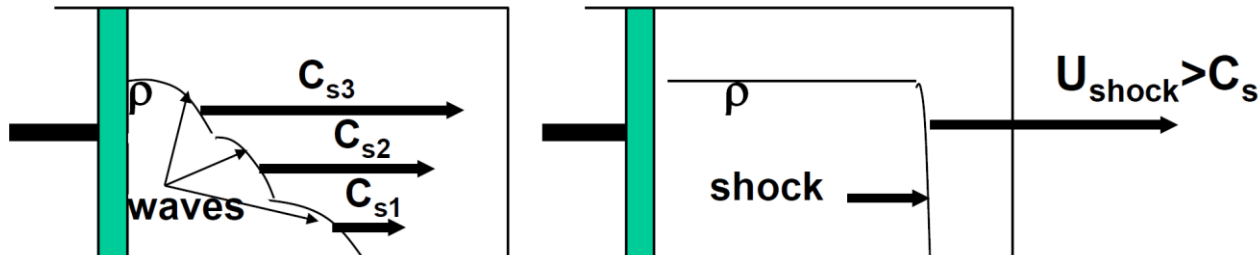

$$C_s \sim \sqrt{\frac{p}{\rho}} \sim \sqrt{\frac{\alpha \rho^{5/3}}{\rho}} \sim \sqrt{\alpha} \rho^{1/3}$$

Ignition can happen by itself or being triggered externally



Self-ignition

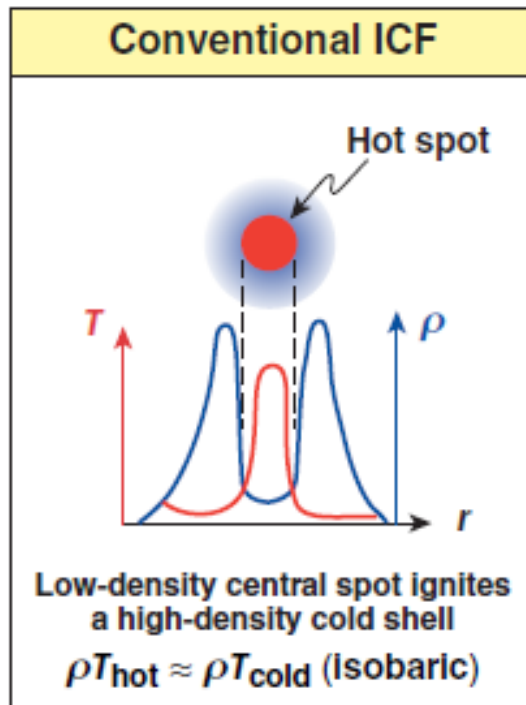

External "spark" for fast ignition

