

PULSED POWER SYSTEM

脈衝功率系統



Po-Yu Chang

Institute of Space and Plasma Sciences, National Cheng Kung University

2024 Fall Semester

Thursday 9:10-12:00

Lecture 5

<http://capst.ncku.edu.tw/PGS/index.php/teaching/>

Online courses:

<https://nckucc.webex.com/nckucc/j.php?MTID=mf87b10f22c1e36d5c4b2337e60d8a847>

Reference



- **Foundations of pulsed power technology, by Jane Lehr & Pralhad Ron**
- **Pulsed power systems, by H. Bluhm**
- **Pulsed power, by Gennady A. Mesyats**
- **J. C. Martin on pulsed power, edited by T. H. Martin, A. H. Guenther, and M. Kristiansen**
- **Pulse power formulary, by Richard J. Adler**

- **Circuit analysis, by Cunningham and Stuller**

Outlines



- Introduction to pulsed-power system
- Review of circuit analysis
- **Static and dynamic breakdown strength of dielectric materials**
 - Gas – Townsend discharge (avalanche breakdown), Paschen's curve
 - Liquid
 - **Solid**
- Energy storage
 - Pulse discharge capacitors
 - Marx generators
 - Inductive energy storage

Methods of improving solid insulator performance



- Layers of insulating films instead of single layer with the same total thickness.
- Improving the contact area at the interface between electrodes and dielectric – metallization and oil impregnation.
- Controlling a nonuniform field – corona guards / equipotential rings.
- Modifying insulator shapes and surface profiles – reduce the interaction of charge carries at the surface.

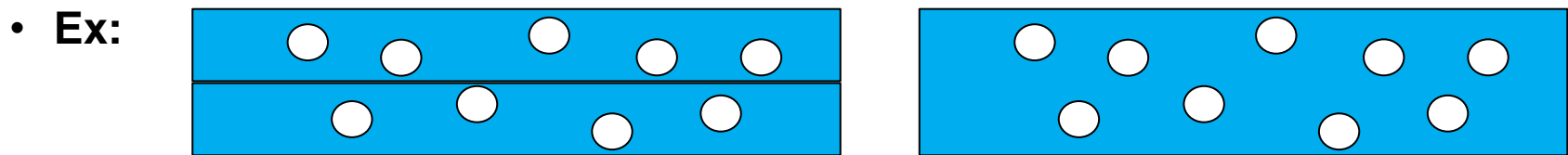

- Ex: insulation in energy storage capacitors

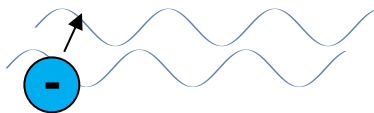

5~7 layers of dielectric films.

Metallization: vapor deposition of Al or Zinc w/ $\delta=0.3$ nm => more layers can be packed leading to higher energy density.

Surge voltage distribution help reducing the chance of breakdown

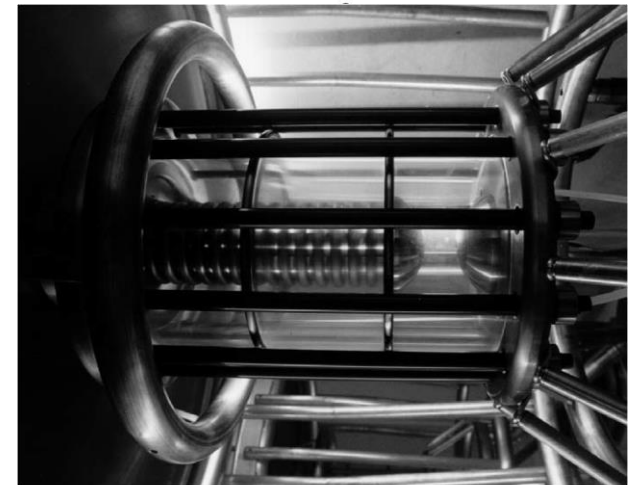
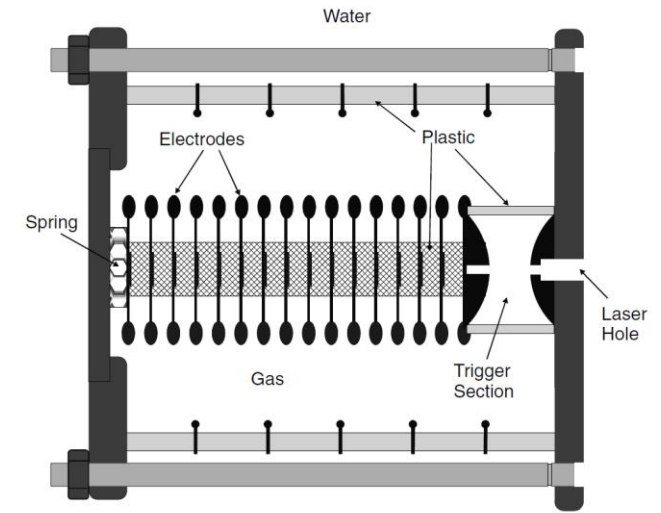
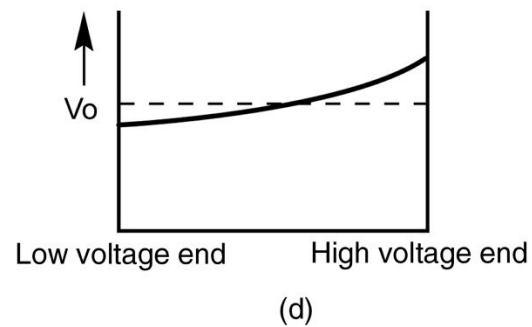
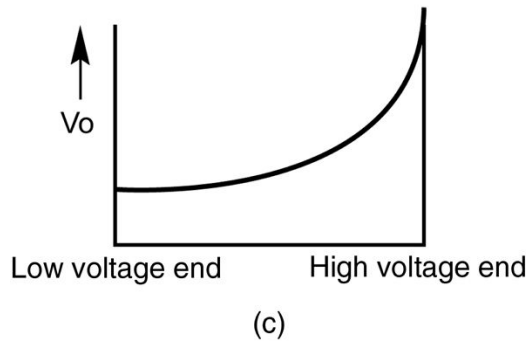
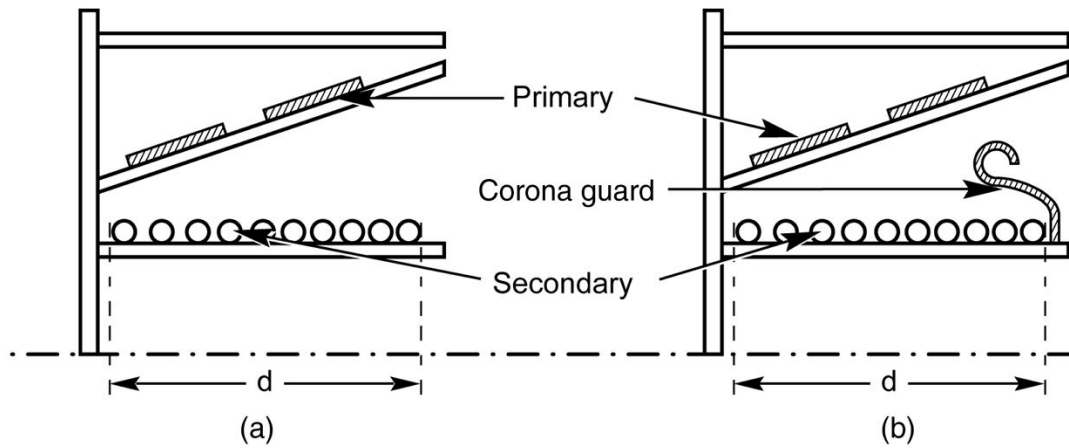
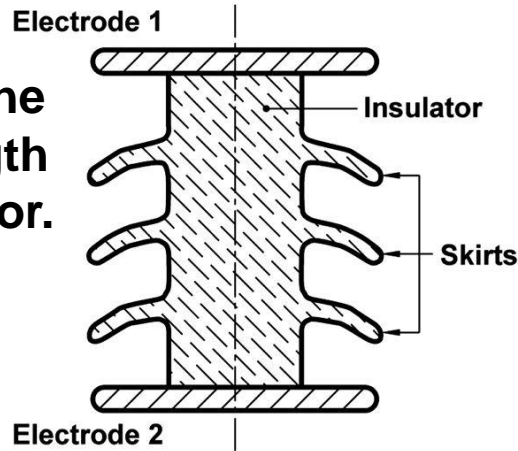

Fig. 4.13. A 4 MV version of a multigap spark switch

Surface flashover in standoff insulators



To increase the effective length of the insulator.



(a)

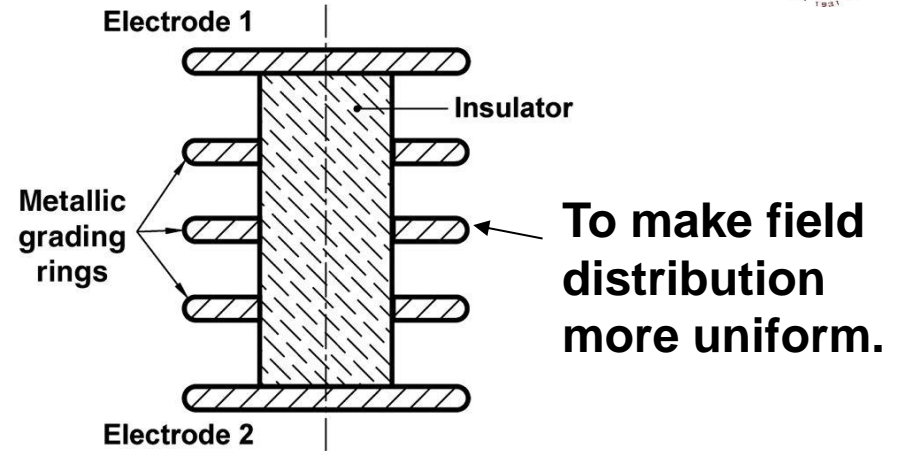

(b)

Metallization on insulator

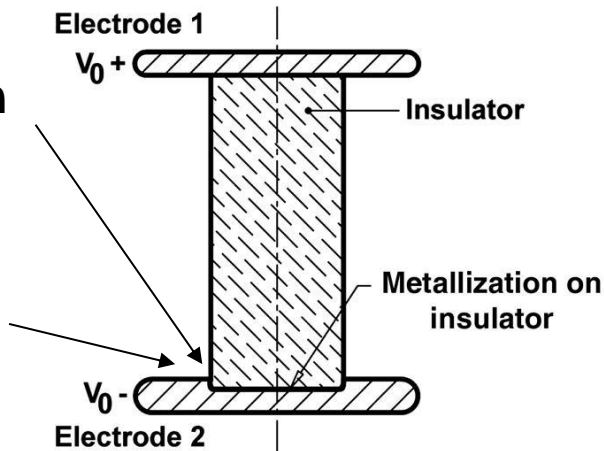

(c)

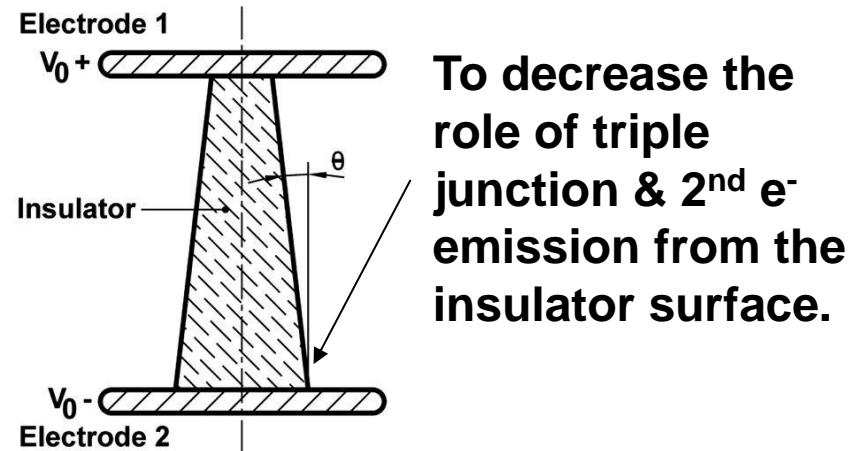

(d)

Breakdown in Vacuum



- **If there is no medium, there is no breakdown.**
- **However, breakdown does take place since charge carriers can be injected from desorbed gas, metal vapors from the electrode.**
- **The insulator surface is an electrically weaker medium than vacuum, i.e., “Surface flashover” across the solid insulator is more possible.**

Examples



- Spark gap switch.
- Diodes for particle beams, x-rays, magnetron.
- Transmission lines for feeding pulsed power into the load.

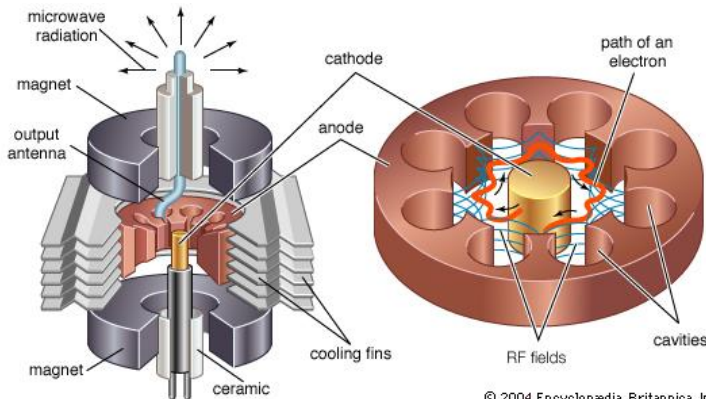
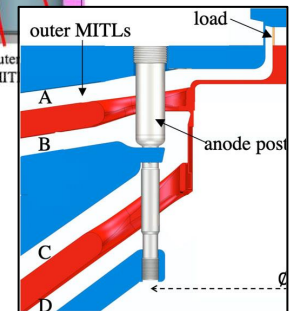
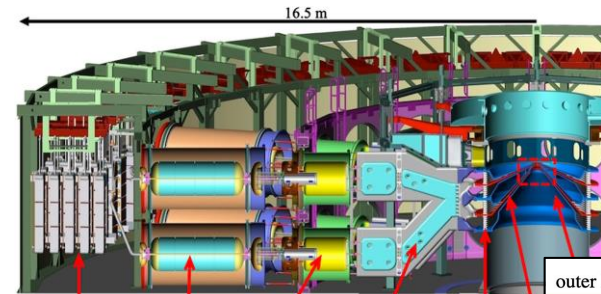
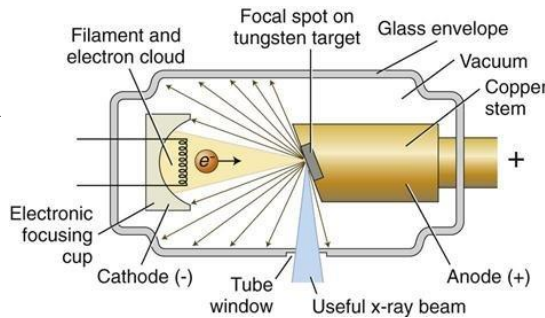
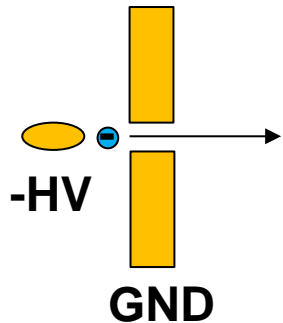
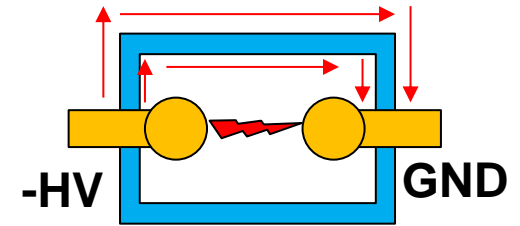

© 2004 Encyclopædia Britannica, Inc.

- https://www.researchgate.net/publication/327816840_X-ray_imaging_using_100_mm_thick_Gas_Electron_Multipliers_operating_in_Kr-CO2_mixtures
- <http://www2.ee.ic.ac.uk/ngai-han.liu08/yr2proj/magnetron.htm>
- N. Bennett, etc., Phys. Rev. Acc. Beams., 22, 120401 (2019)

Vacuum breakdown mechanisms – ABCD mechanism



- For $pd < 10^{-3}$ Torr-cm, electrons cross the gap without colliding gas molecular.

- ABCD mechanism: $AB+CD \geq 1$

More and more electrons are generated

=> conductivity increases => breakdown.

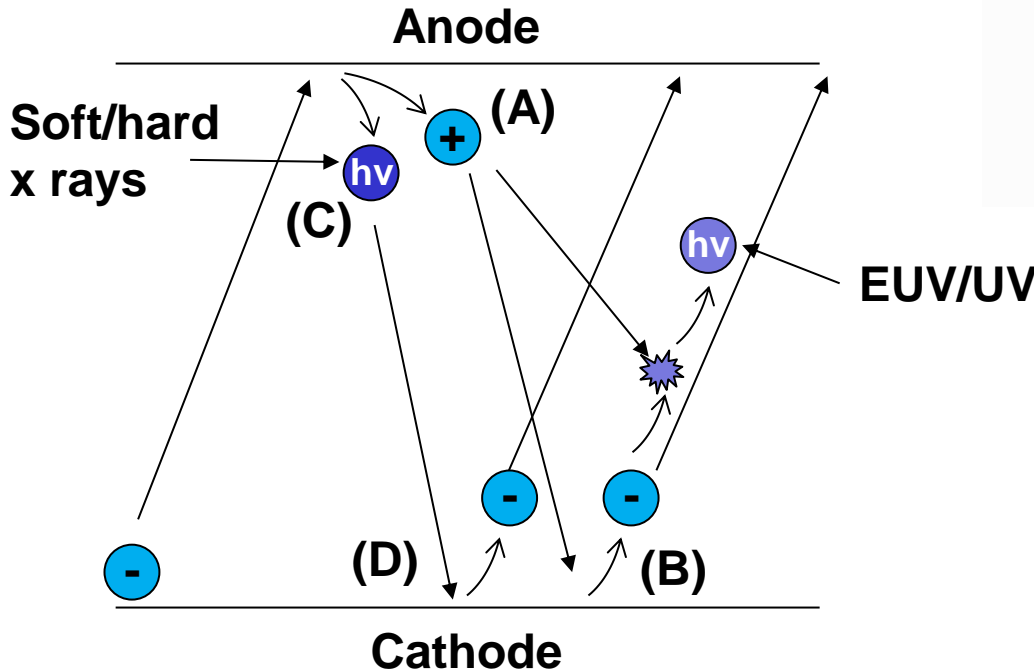
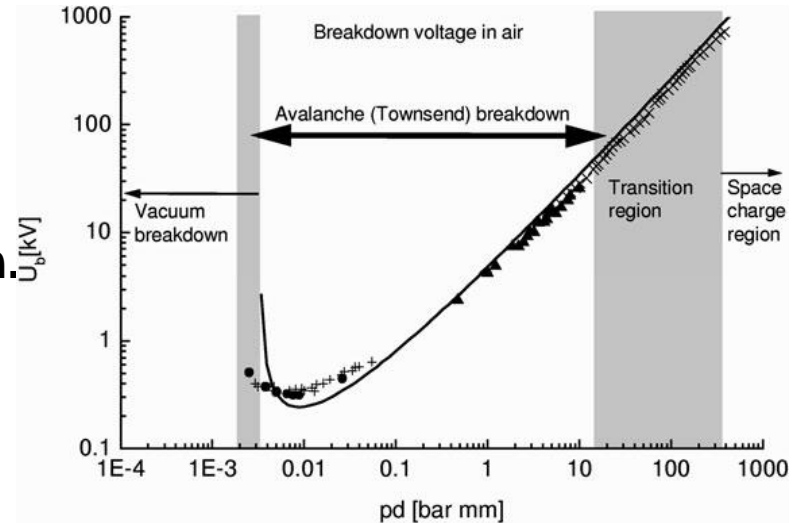

Characteristics of ABCD breakdown



- The probability of ABCD breakdown is high at large impulse field intensity:

- High gas evolution from electrode due to desorption.
- Metal vapor formation.
- Unfavorable micro-injection geometry.

- Field emission initiated breakdown:

- Fowler-Nordheim (FN) field emission:

$$j_c = C_1 E_p^2 e^{-C_2/E_p} \text{ A/cm}^2$$

$$C_1 = \frac{1.65 \times 10^{-6}}{\psi t^2(y)} \quad \psi: \text{ work function}$$

$$y = 3.79 \times 10^{-4} \frac{\sqrt{E_p}}{\psi}$$

$$C_2 = 6.83 \times 10^7 \psi^{3/2} v(y)$$

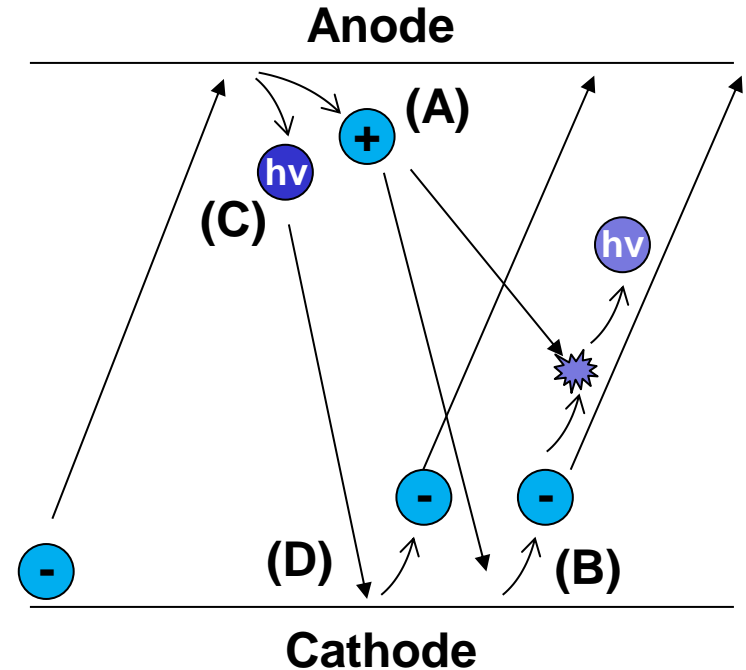

Potential breakdown conditions



- For $E_p = 10^6 - 10^8$ V/cm, $j_c = 10^8 - 10^{10}$ A/cm² => leads to breakdown.

$$j_c = C_1 E_p^2 e^{-C_2/E_p} \text{ A/cm}^2$$

- j_c => joule heating of microprojection => melting, vaporization, plasma forming => ionization/breakdown.
- High-energy electron beam on anode => heating => metal vapor
- Low work function for cathode => high field emission.

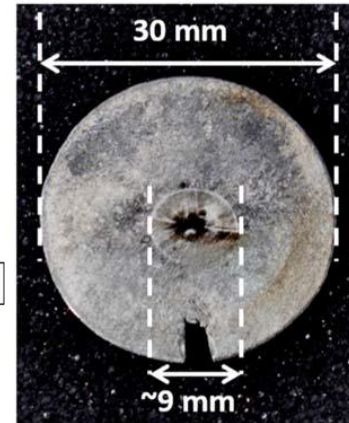
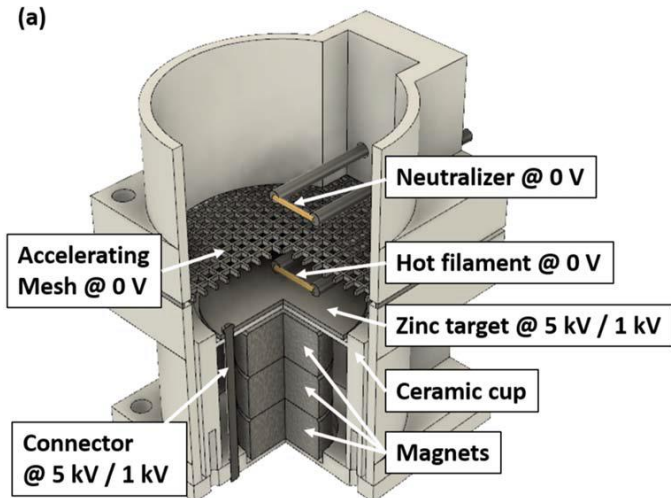
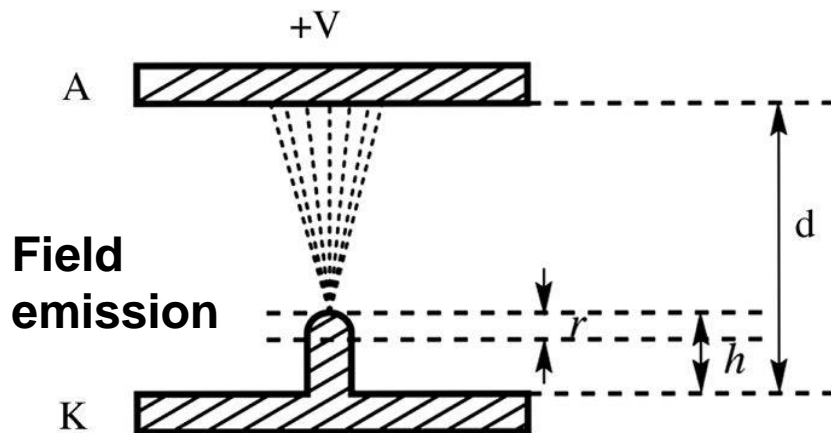

- K.Y. Chen, P.-Y. Chang, and W.-Y. Lin, Plasma Source Sci. Technol., 29, 065021 (2020)

Microparticle-initiated breakdown



- Loosely adhering material being detached from electrode due to electrostatic force.
- Micro projections are made from joule heating by field emission current.
- Vaporization of the anode material by pulsed heating by accelerated electron beam.
- Vaporization of the cathode material by joule heating.

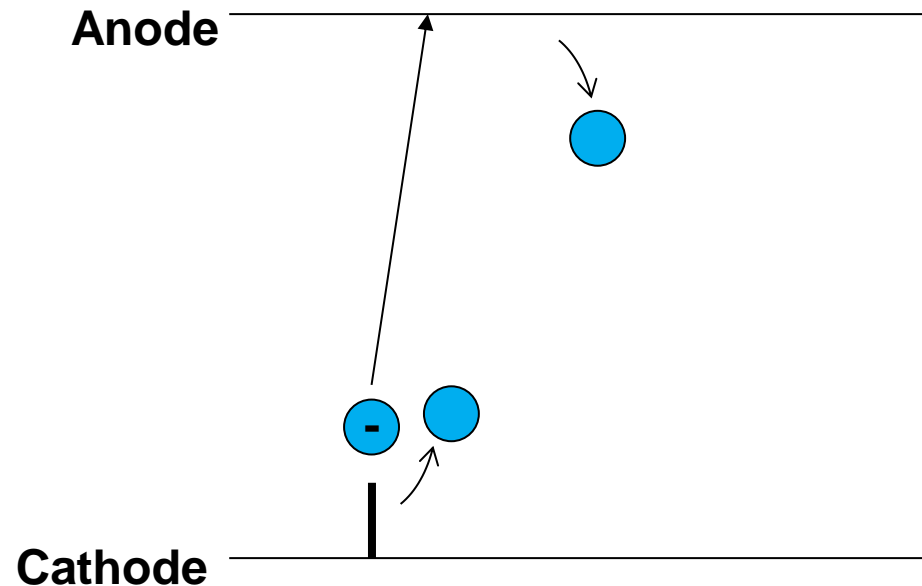

Improving vacuum insulation performance



- **Conditioning:** with successive breakdown events, the breakdown voltage steadily increases and attain a steady value.

Anode _____

- **Current conditioning:**

- $I \sim 100\text{s } \mu\text{A}$.

Cathode 

- A breakdown pulse removes a microprojection and the following pulse shifts to another microprojection site.

- 30 mins~ few hours.

- AC/DC are employed for both electrodes.

- Start from 50% of expected $V_{\text{breakdown}}$

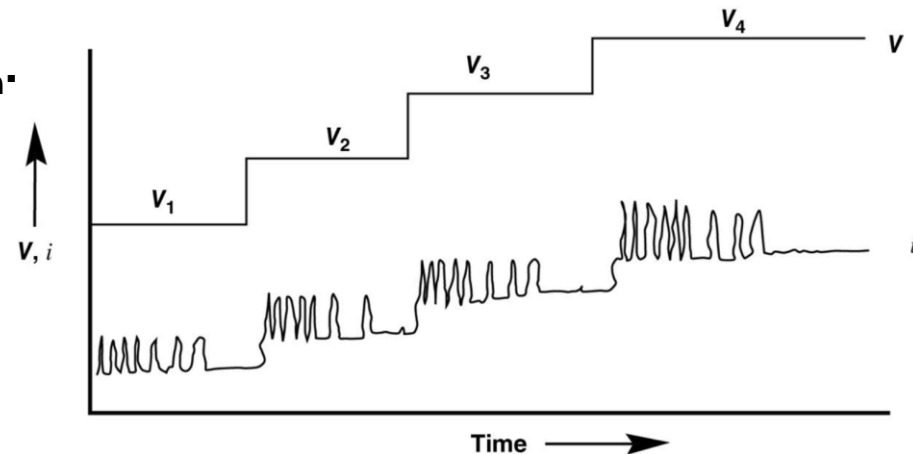

Improving vacuum insulation performance



- **Spark condition: impulse voltages with width of 100s ns is used.**
 - $I \leq$ few Ampere.
- **Chemical cleaning:**
 - reducing impurities.
 - Valence band energy is changed. (changing work function.)
- **Glow discharge cleaning:**
 - Sputter cleaning.
 - A continuous flow of gas allowed the removal of impurities.
 - 30-60 mins using H, He, Ar, N₂, SF₆, dry air, then use Ar to remove O₂.
- **Outgassing and annealing: heat to T=250 ~ 1500 °C for several hours for outgassing.**

Improving vacuum insulation performance



- **Surface treatment and coating**

- Cobalt-molybdenum (鈷-鉬)
- Cobalt-tungsten (鈷-鎢)
- Ion implantation – work hardening of the surface.

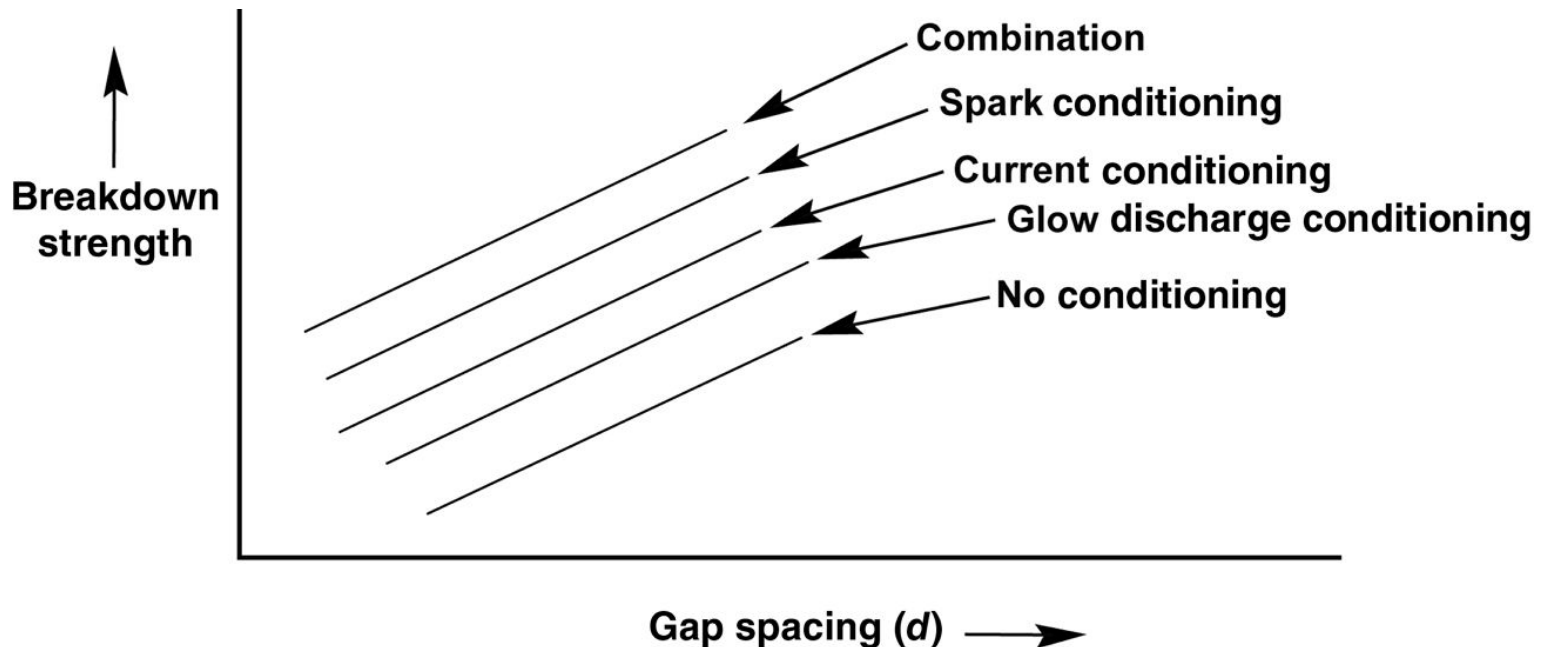
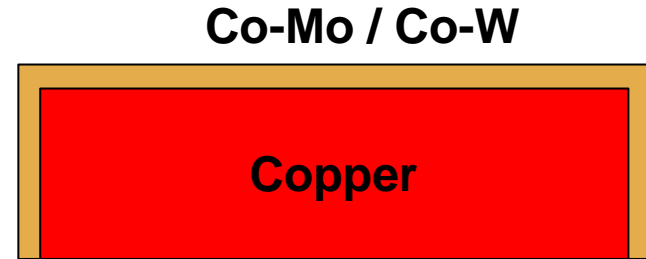

Triple-point junction modifications



- If imperfect at the triple-point junction, there may be voids or gaps.
=> E field enhancement => enhanced field emission.
- To improve:
 - Metalizing the insulator surface at contact => a firm contact.
 - Elimination of the void and the shielding of the emitted area by cathode. Anode doesn't help!

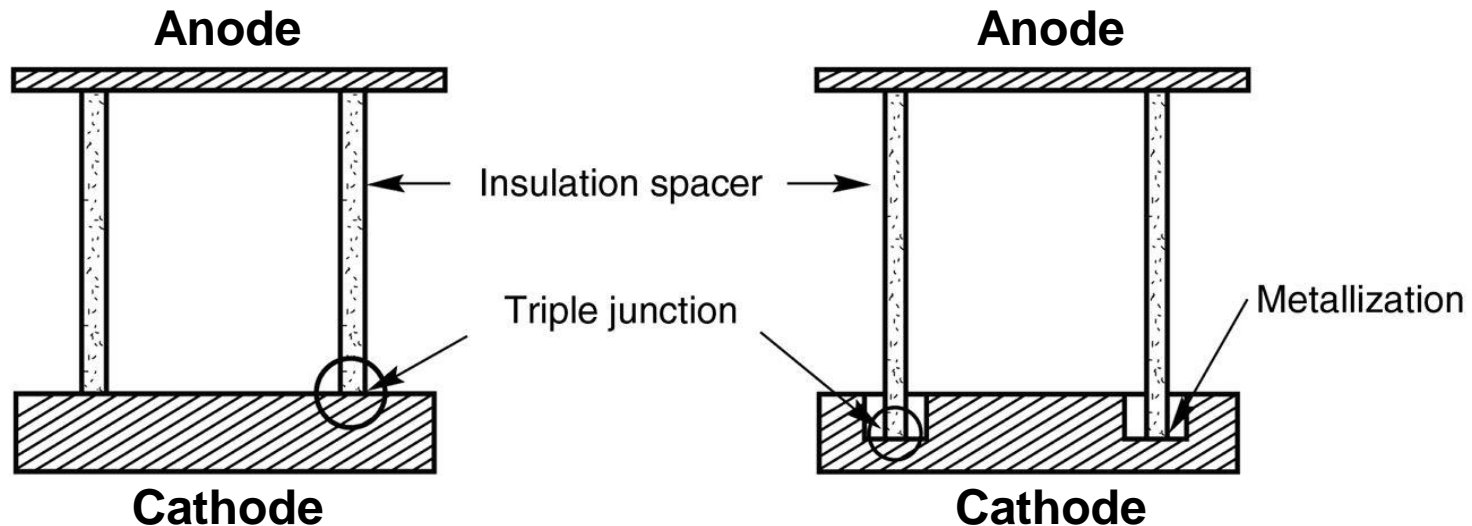

Vacuum magnetic insulation

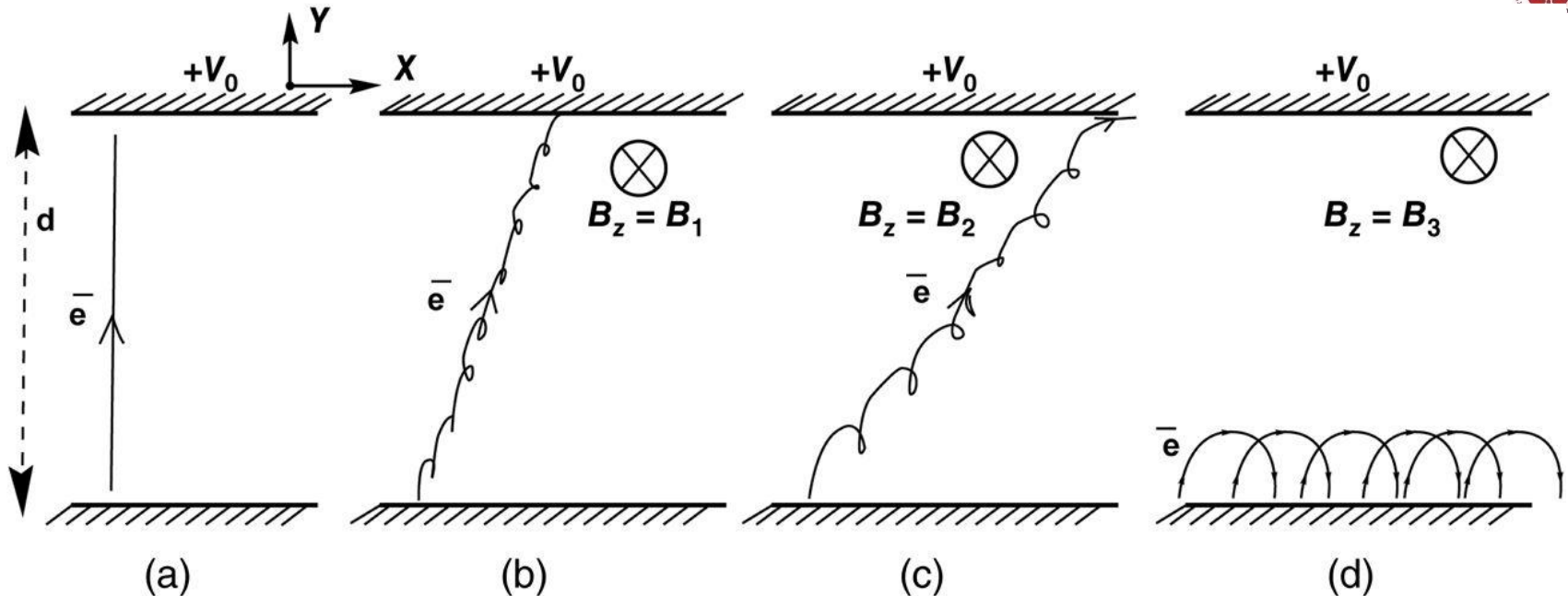

- The crossed magnetic field can be externally applied.
- Self-generated magnetic field is also possible when current is high enough:
 - Magnetic Insulation Transmission Line (MITL).
 - Magnetic Insulation Line Oscillator (MILO) for high power microwave source.

Magnetic Insulation Transmission Line is commonly used in transmitting high current in vacuum

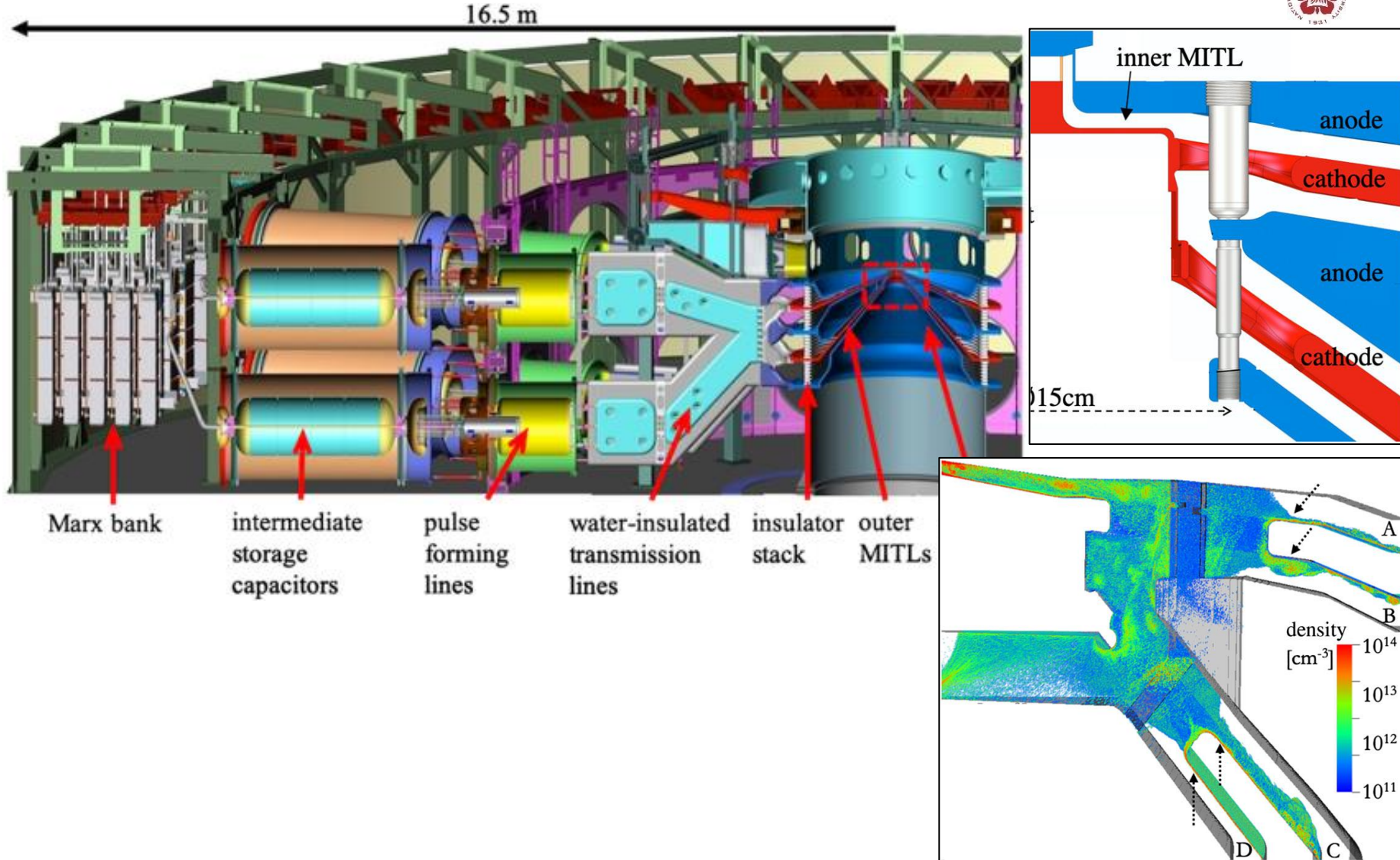

Ion diode using vacuum magnetic insulation

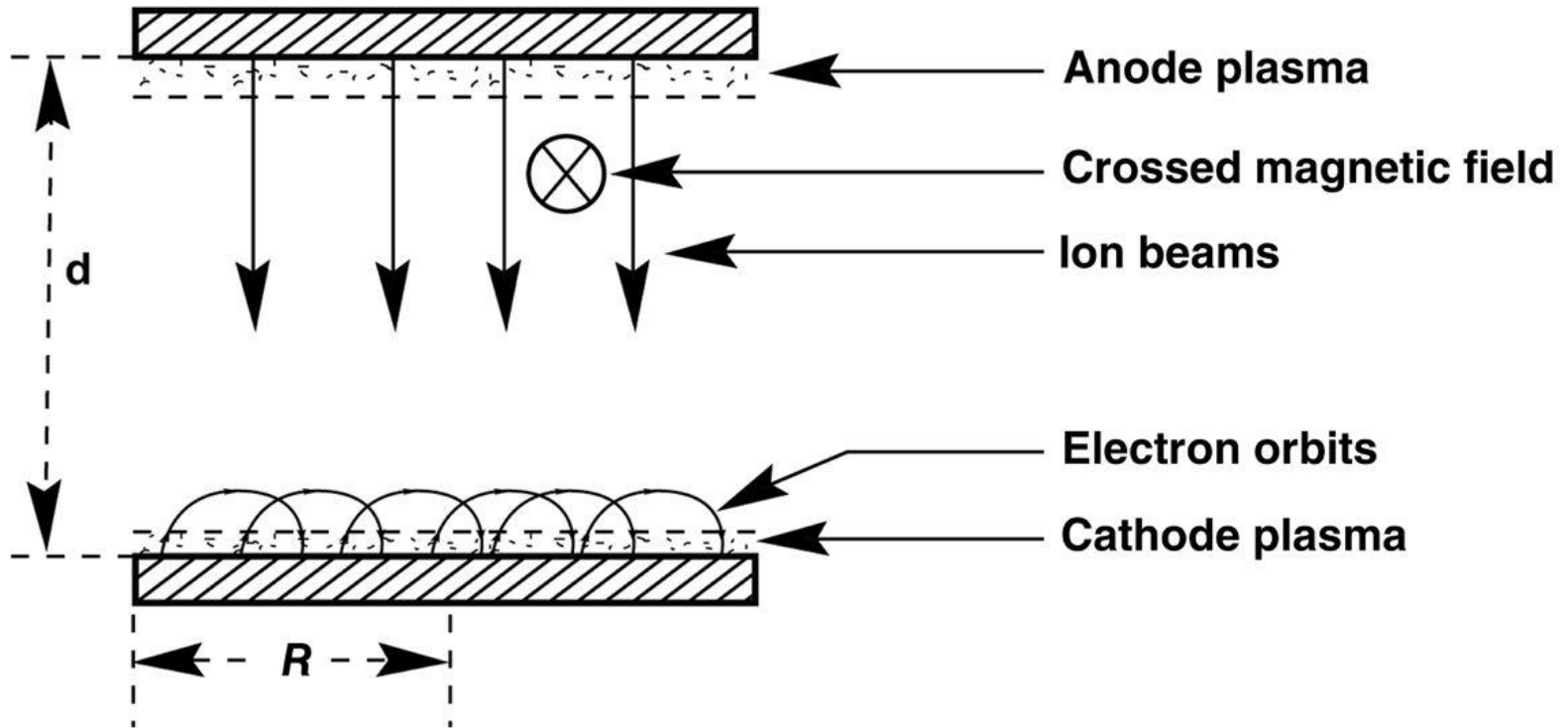

- $m_i > m_e$.

Surface flashover across solid in vacuum



- V_B increases rapidly at lower pressure due to lack of ionizing collisions particles.
- Process of surface flashover
 - The dielectric surface is the source of electrons to feed the developing avalanche by a process known as 2nd electron emission.
 - Electro-stimulated desorption: e⁻ impacting the surface liberates gas trapped or adsorbed by the surface.
- 2nd e⁻ emission from dielectric surface requires $E_k > E_0$ to liberate e⁻.
- If $E_k < E_0$, charge builds up causing the following e⁻ are away from the surface and gain more energy till $E_k > E_0$ and generate more e⁻.
- $V_B \sim \sqrt{l}$

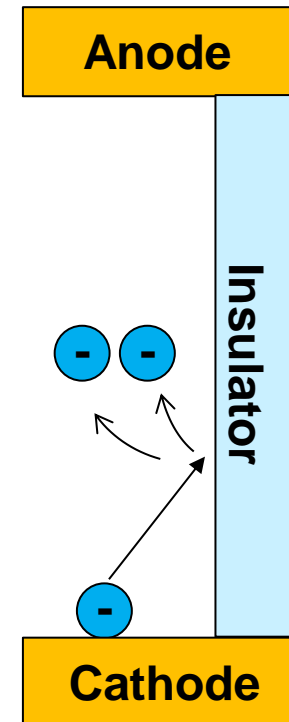

Surface flashover across solid in vacuum



- V_B increases rapidly at lower pressure due to lack of ionizing collisions particles.
- Process of surface flashover
 - The dielectric surface is the source of electrons to feed the developing avalanche by a process known as 2nd electron emission.
 - Electro-stimulated desorption: e⁻ impacting the surface liberates gas trapped or adsorbed by the surface.
- 2nd e⁻ emission from dielectric surface requires $E_k > E_0$ to liberate e⁻.
- If $E_k < E_0$, charge builds up causing the following e⁻ are away from the surface and gain more energy till $E_k > E_0$ and generate more e⁻.
- $V_B \sim \sqrt{l}$

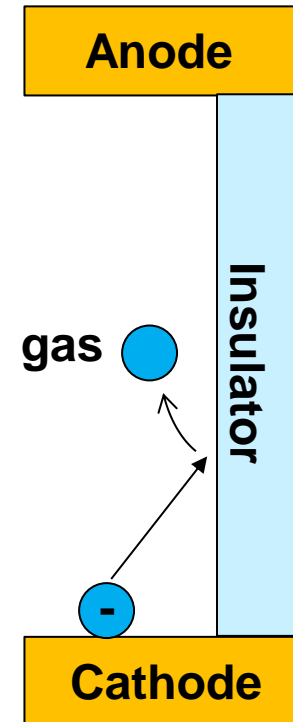

Surface flashover across solid in vacuum



- V_B increases rapidly at lower pressure due to lack of ionizing collisions particles.
- Process of surface flashover
 - The dielectric surface is the source of electrons to feed the developing avalanche by a process known as 2nd electron emission.
 - Electro-stimulated desorption: e⁻ impacting the surface liberates gas trapped or adsorbed by the surface.
- 2nd e⁻ emission from dielectric surface requires $E_k > E_0$ to liberate e⁻.
- If $E_k < E_0$, charge builds up causing the following e⁻ are away from the surface and gain more energy till $E_k > E_0$ and generate more e⁻.
- $V_B \sim \sqrt{l}$

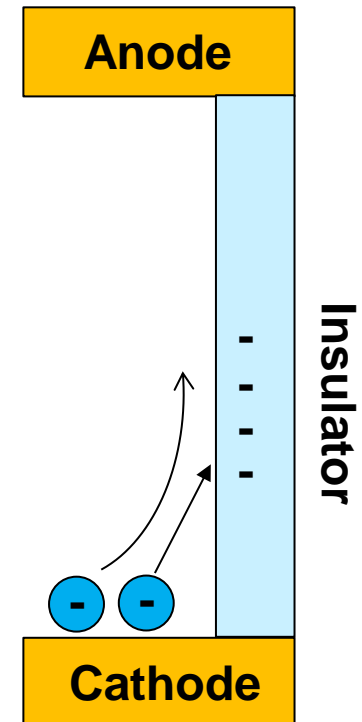

Some examples of surface flashover of solid dielectric

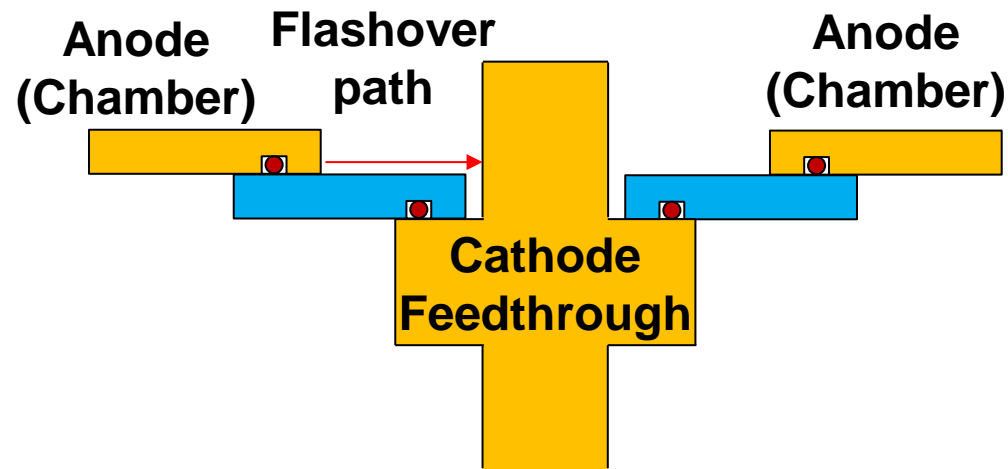
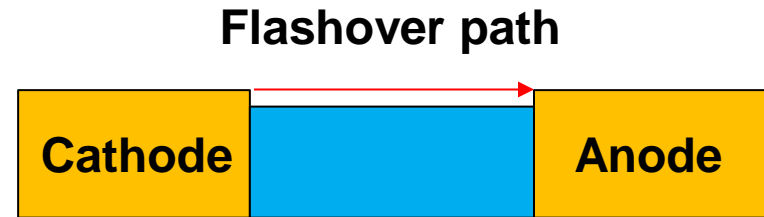
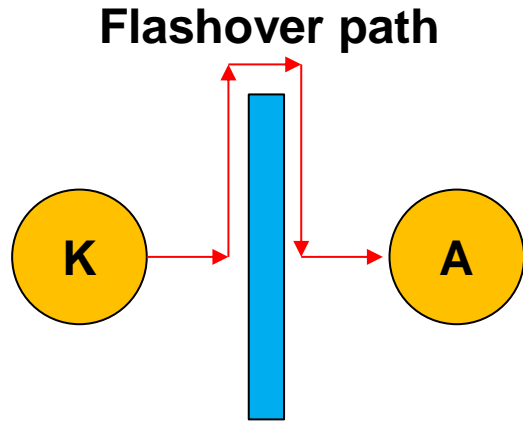

Some examples of surface flashover of solid dielectric

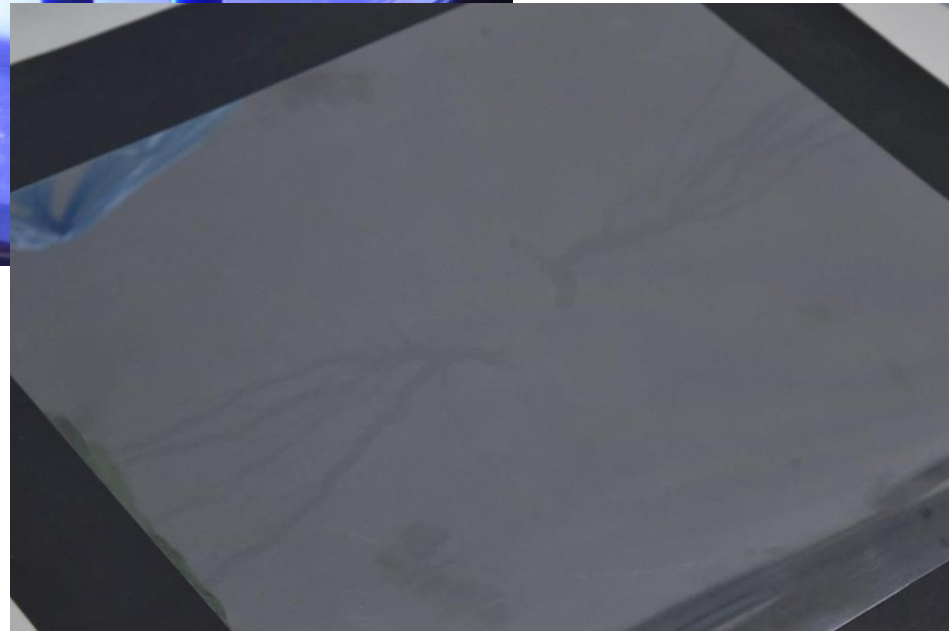
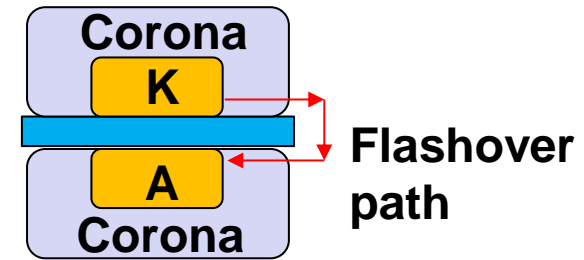
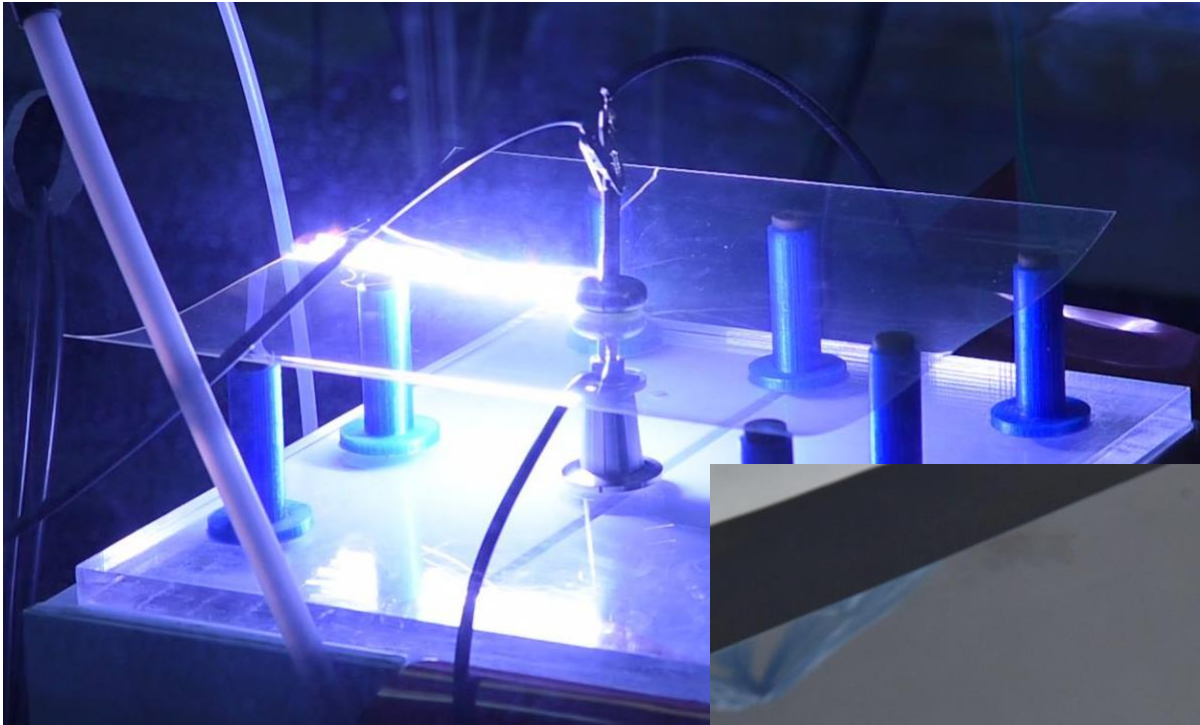

A kraft paper with high resistivity can kill the corona

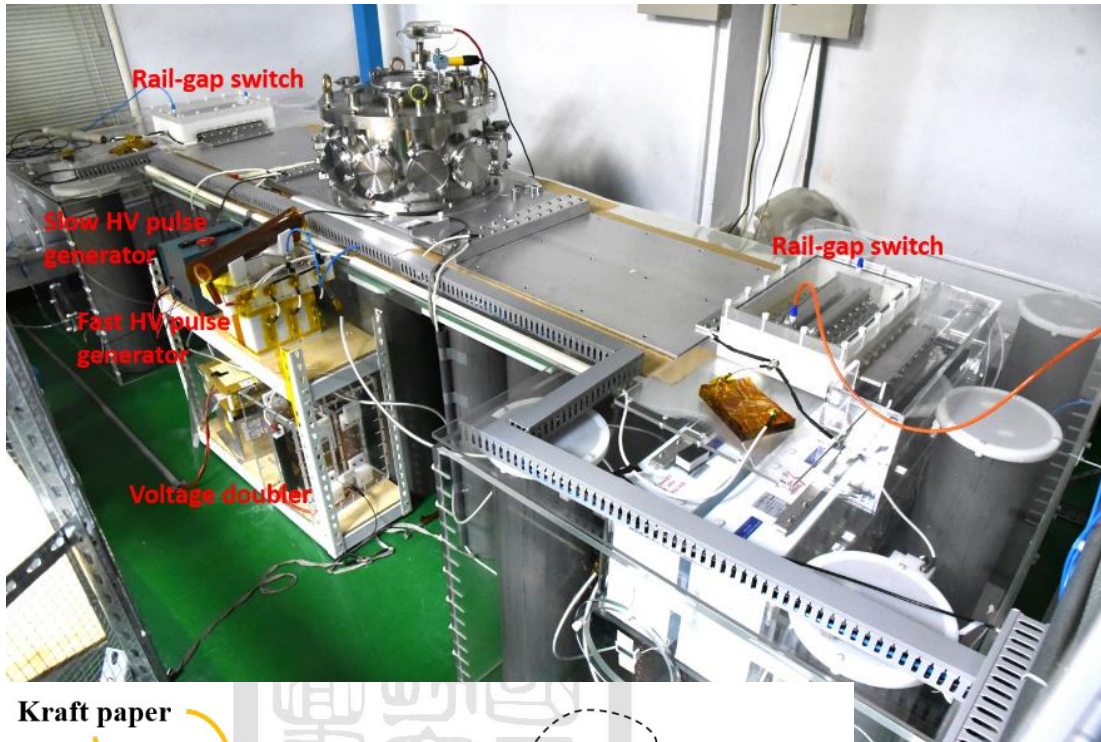

- High but finite resistivity will bring the charge away from the electrodes. Corona is harder to be initiated.

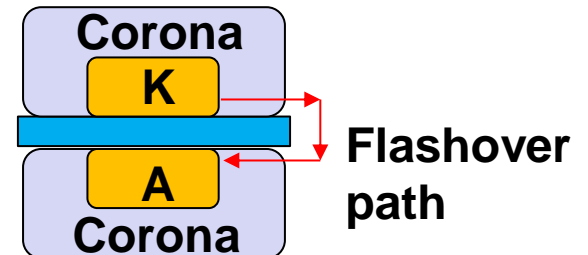
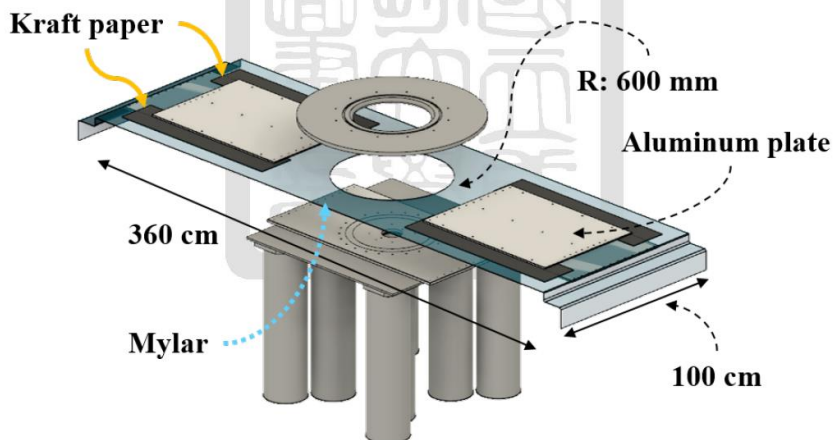
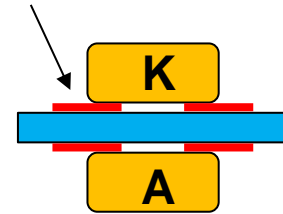

To avoid flashover, need to avoid avalanche on the insulator surface

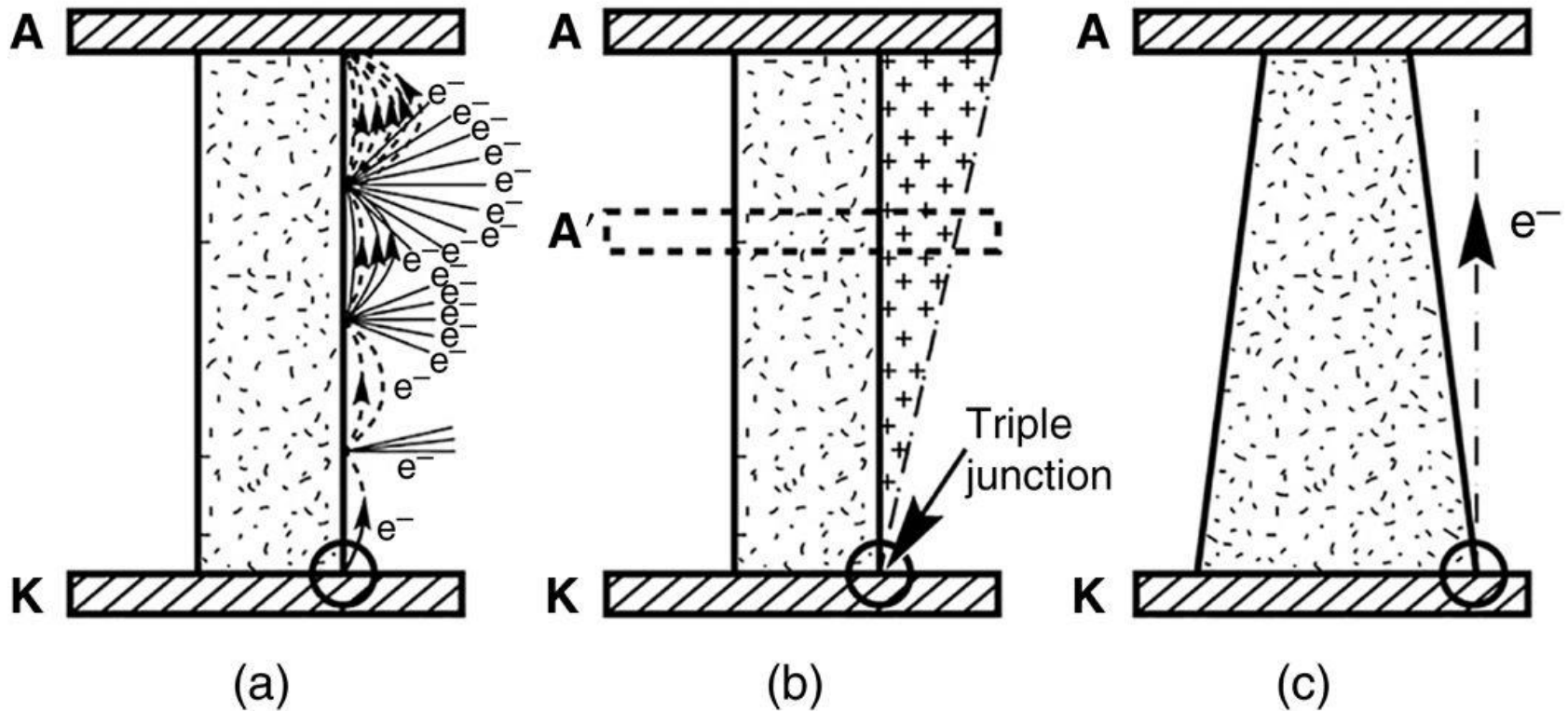

Ways to avoid surface flashover in standoff insulators



To increase the effective length of the insulator.

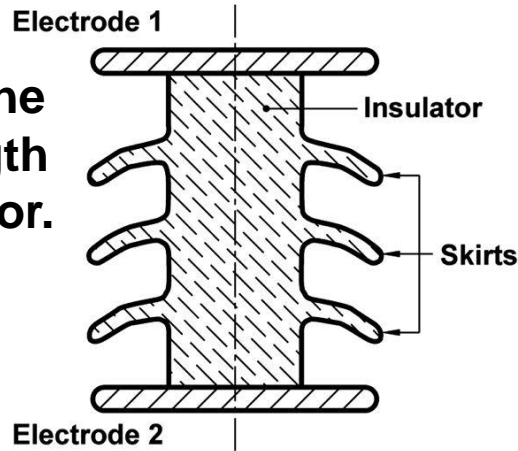

(a)

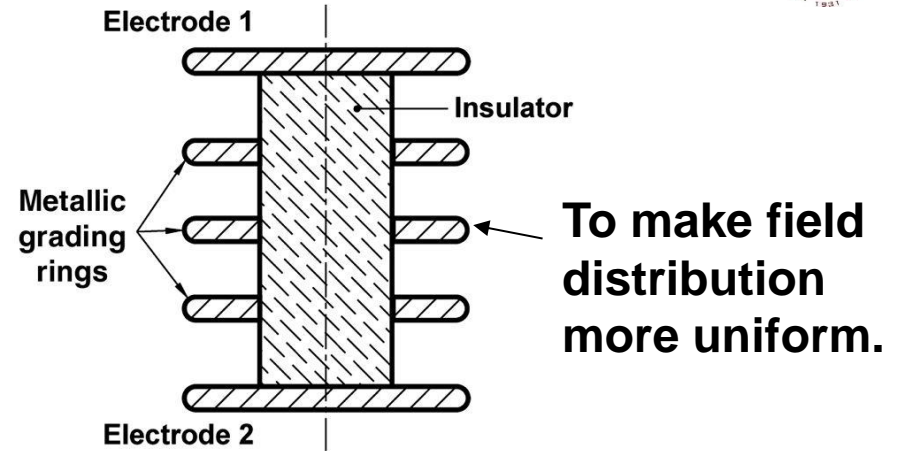

(b)

Metallization on insulator

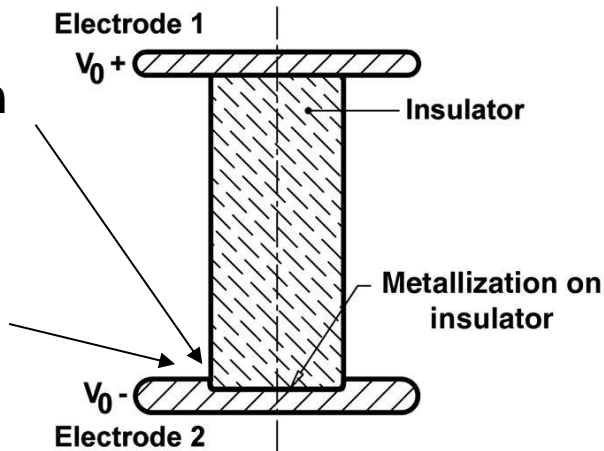

(c)

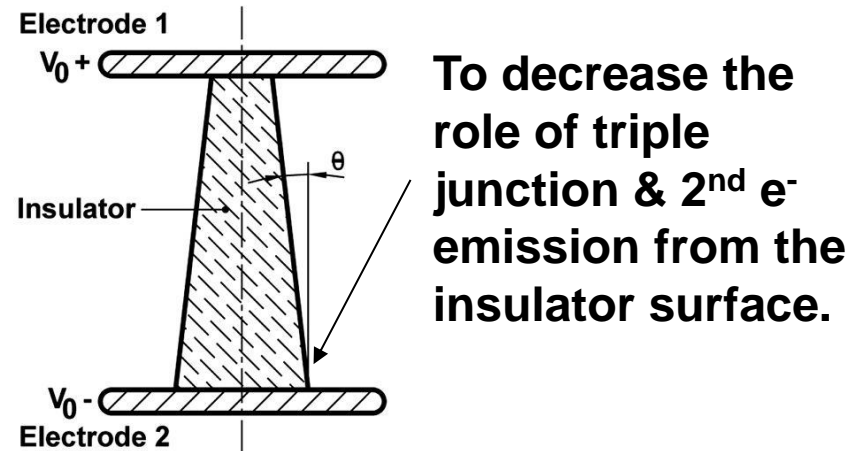

(d)

• No line of sight!

Composite dielectrics



$$\epsilon_1 E_1 = \epsilon_2 E_2 \quad E_1 = \frac{V_1}{d_1}, E_2 = \frac{V_2}{d_2}$$

$$\epsilon_1 \frac{V_1}{d_1} = \epsilon_2 \frac{V_2}{d_2}, \quad V_0 = V_1 + V_2$$

$$V_1 = \frac{\epsilon_2 d_1}{\epsilon_1 d_2} V_2$$

$$V_0 = \frac{\epsilon_2 d_1}{\epsilon_1 d_2} V_2 + V_2 = \frac{\epsilon_2 d_1 + \epsilon_1 d_2}{\epsilon_1 d_2} V_2$$

$$V_2 = \frac{\epsilon_1 d_2}{\epsilon_2 d_1 + \epsilon_1 d_2} V_0$$

$$E_2 = \frac{\epsilon_1}{\epsilon_2 d_1 + \epsilon_1 d_2} V_0 = \frac{V_0}{\epsilon_2/\epsilon_1 d_1 + d_2}$$

$$E_1 = \frac{\epsilon_2}{\epsilon_1} E_2 = \frac{\epsilon_2}{\epsilon_2 d_1 + \epsilon_1 d_2} V_0 = \frac{V_0}{d_1 + \epsilon_1/\epsilon_2 d_2}$$

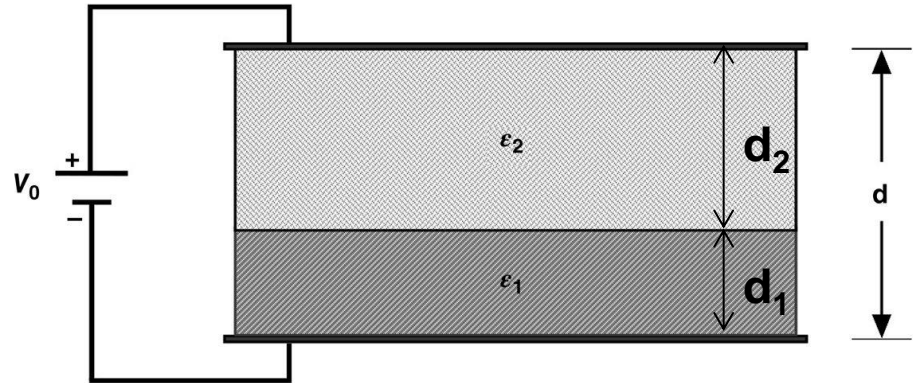

$$E_0 \equiv \frac{V_0}{d} = \frac{V_0}{d_1 + d_2}$$

$$\text{if } \frac{\epsilon_2}{\epsilon_1} > 1, d_1 + \frac{\epsilon_1}{\epsilon_2} d_2 < d_1 + d_2 = d$$

$$\frac{\epsilon_2}{\epsilon_1} d_1 + d_2 > d_1 + d_2 = d$$

$$E_1 > E_0, E_2 < E_0$$

- The lower dielectric constant of the material creates a higher electric field.

Outlines



- Introduction to pulsed-power system
- Review of circuit analysis
- Static and dynamic breakdown strength of dielectric materials
 - Gas – Townsend discharge (avalanche breakdown), Paschen's curve
 - Liquid
 - Solid
- **Energy storage**
 - **Pulse discharge capacitors**
 - Marx generators
 - Inductive energy storage

Electric energy storage requirements



- High energy density.
- High breakdown strength.
- High discharge current capability.
- Long storage time (low rate of energy leakage).
- High charging and discharging efficiency.
- Large power multiplication
(\equiv power during discharge / power during charging).
- Repetition rate capability and long lifetime.
- Low specific cost.

Pulse discharge capacitors



- Pulsed power systems are still based on high-voltage energy-storage capacitors due to: reliability, repetition, fast closing switches, and the energy hold time is longer than inductive storage devices.
- An insulating margin around the metal electrodes prevents flashover between the electrodes.

$$W_c = \frac{1}{2} cV^2$$

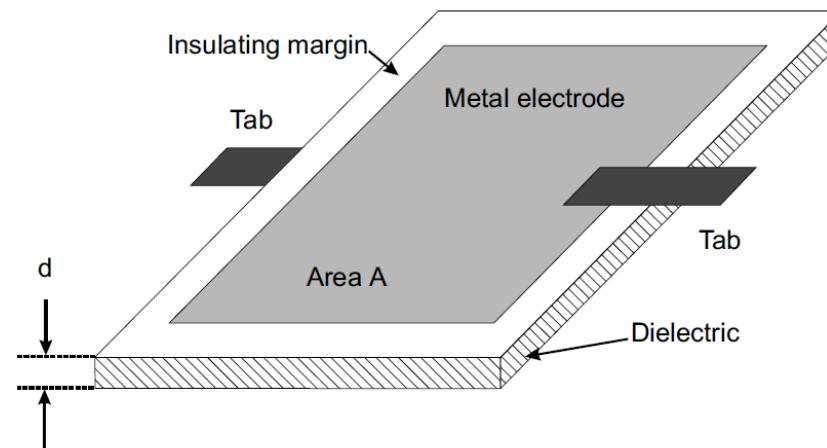

Lumped circuit model of a capacitor

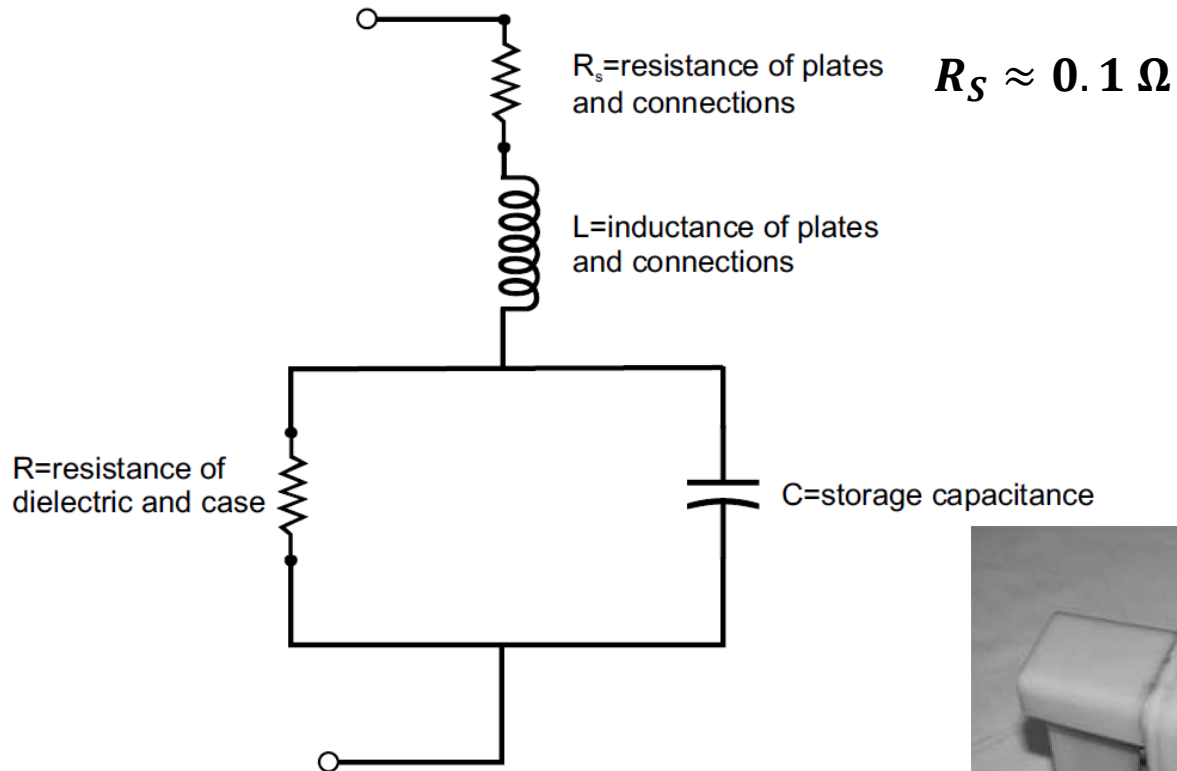

$$I_{\text{peak}} = \frac{V}{\sqrt{L/C}}$$

$$\text{Impedance} \equiv L/C$$

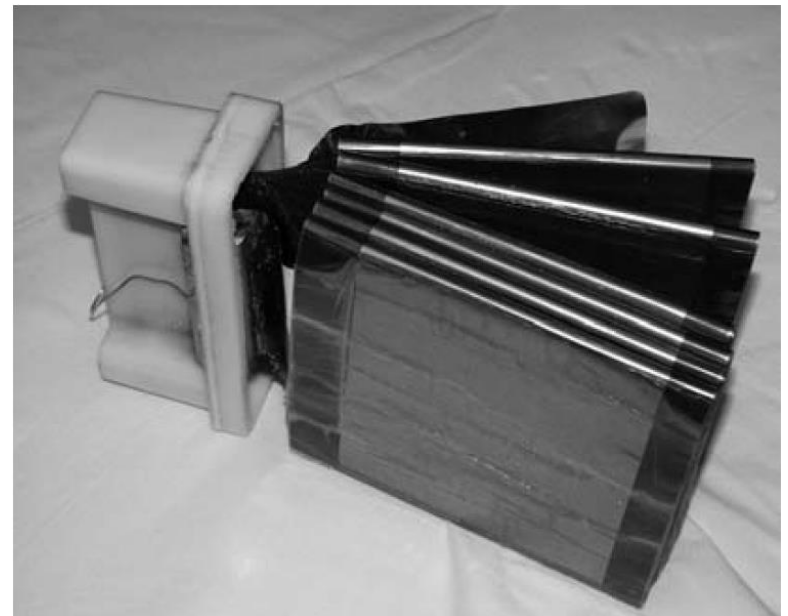

High voltage super capacitor

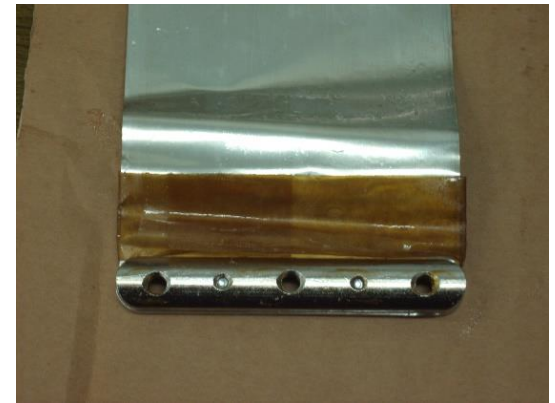

Oil-impregnated paper as the dielectric

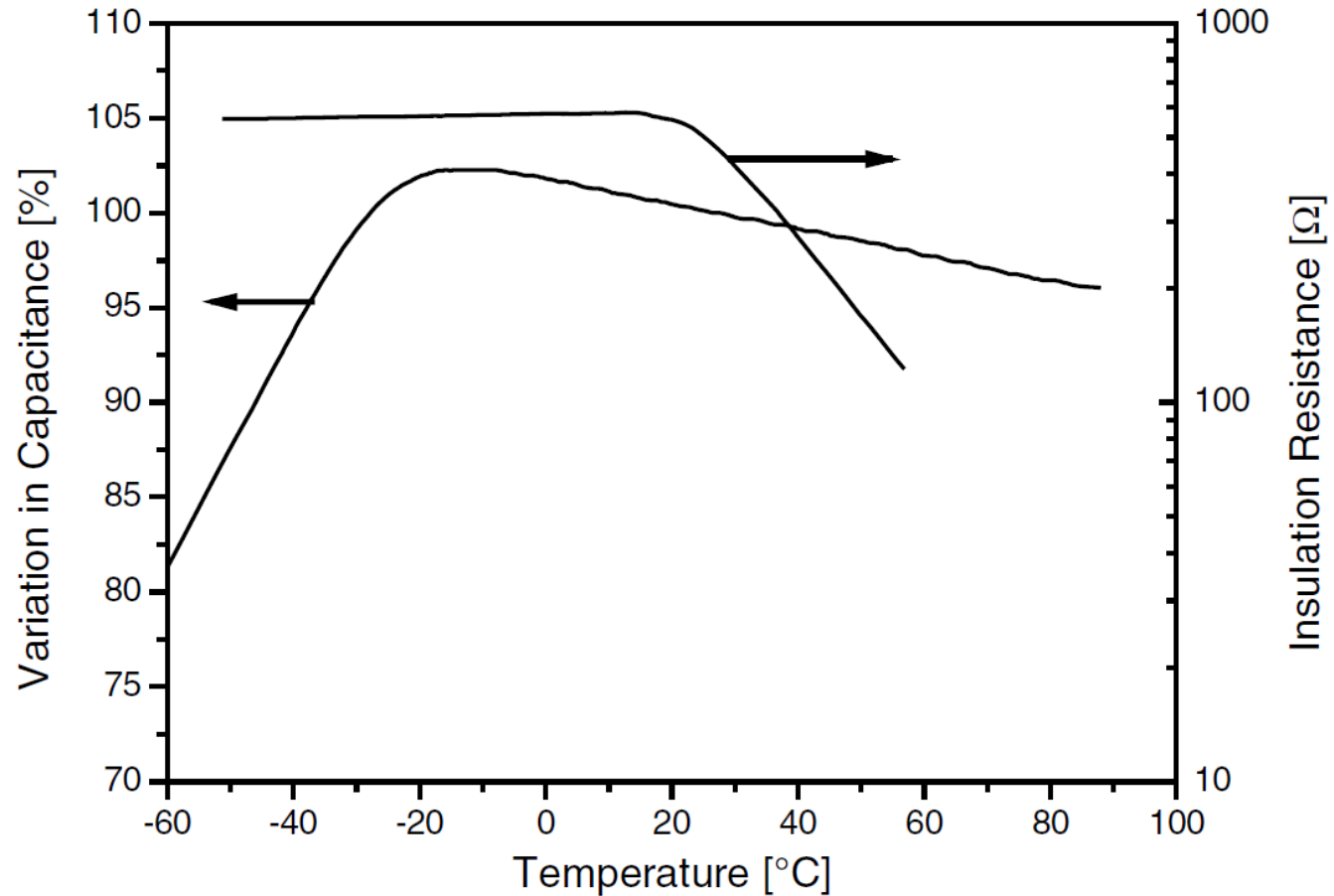

Properties of some dielectric materials used for the insulation of high-voltage capacitors



Material	E	E_{DB} (kV/cm)	Tan(δ)
Impregnated paper	3-4	200-800	0.01-0.03
Epoxy	3.5	320	0.014
Mylar	3	400	0.001
Polypropylene	2.55	256	0.0005
Teflon	2.1	216	0.0002
Kapton	3.4	2800 (25 μ m)	0.01
Plexiglas	3.3	200	0.009
Transformer oil	3.4	400	0.0002
Aluminiumoxide	8.8	126	0.01
Bariumtitanate	1143	30	0.01
Glass (borosilicate)	4.84	157	0.0036

Properties of dielectric materials



- **Electric strength (dielectric strength), influenced by**
 - **Conditions of operations.**
 - **Temperature.**
 - **Pressure.**
 - **Humidity.**
 - **Voltage reversal.**
- **Dielectric constant ϵ .**
- **Loss factor $\tan(\delta)$.**

Characteristics of capacitors



- Dependence of the high-voltage strength of a capacitor
 - Breakdown strength of the dielectric.
 - Shape, area, metal of the terminals.
 - Bonding to the insulator that fills the case.
- The instantaneous capacitance differs from the static value when a capacitor is charged or discharged quickly. It is the result from the finite relaxation time of the polarization, which is also responsible for the dielectric losses.

Polar molecules rotate if the electric field oscillates. The rotation of the polar molecules causes the energy loss.

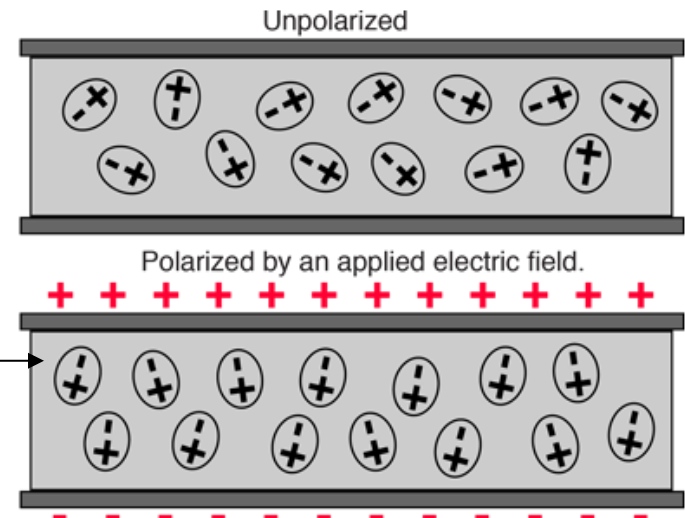

Polarization P and displacement D will lag behind in phase relative to the applied E field



$$E = E_o \cos(\omega t) \quad D = D_o \cos(\omega t - \delta) = D_1 \cos(\omega t) + D_2 \sin(\omega t)$$

$$D_1 \equiv D_o \cos(\delta) \quad D_2 \equiv D_o \sin(\delta)$$

$\frac{D_o}{E_o} \rightarrow$ frequency dependent

$$\epsilon'(\omega) = \frac{D_1}{E_o} = \frac{D_o}{E_o} \cos(\delta) \quad \epsilon''(\omega) = \frac{D_2}{E_o} = \frac{D_o}{E_o} \sin(\delta) \quad \tan(\delta) = \frac{\epsilon''(\omega)}{\epsilon'(\omega)}$$

- **Current density in the capacitor:**

$$j = \frac{dq}{dt} = \frac{dD}{dt} = \omega[-D_1 \sin(\omega t) + D_2 \cos(\omega t)]$$

$$\nabla \times \vec{E} = -\frac{\partial \vec{B}}{\partial t}$$

- **q: surface charge density on the capacitor plate.**
- **dD/dt: displacement current.**

$$\nabla \times \vec{H} = \vec{j}_f + \frac{\partial \vec{D}}{\partial t}$$

Polarization of a material has two terms with different response time



- Energy density ψ (per unit volume and time):

$$\text{Power} = IV \times \frac{Ad}{Ad} = \frac{I}{A} \frac{V}{d} Ad = jEAd \quad \psi = \frac{\text{Power}}{Ad} = jE$$

$$\begin{aligned} \Psi &= \frac{\omega}{2\pi} \int_0^{2\pi/\omega} jE dt = \frac{\omega}{2\pi} \int_0^{2\pi/\omega} \omega[-D_1 \sin(\omega t) + D_2 \cos(\omega t)] E_0 \cos(\omega t) dt \\ &= \frac{\omega}{2} E_0 D_2 = \frac{\omega}{2} E_0 D_0 \sin(\delta) \approx \frac{\omega}{2} E_0 D_0 \tan(\delta) \quad (\text{Small } \delta) \end{aligned}$$

- Dielectric polarization: $P = P_s + P_d$

P_s : spontaneous polarization due to electronic and atomic polarization.

P_d : dipolar polarization appears in substances composed of molecules that have permanent electric dipole moments.

- If the field is suddenly switched on, P_d relaxes to final, static value with a time constant τ :

$$P = P_s + P_d(1 - e^{-t/\tau})$$

- Energy density in a capacitor: $\Phi = \frac{1}{2} \epsilon_0 E^2 + \frac{1}{2} PE$

There are two terms with different response time in energy density of a capacitor



- If the field is suddenly switched on, P_d relaxes to final, static value with a time constant τ :

$$P = P_S + P_d(1 - e^{-t/\tau})$$

- Energy density in a capacitor:

$$\Phi = \frac{1}{2} \epsilon_o E^2 + \frac{1}{2} PE$$

- A fast term: time dependent can be neglected at the usual switching speed.
- A relaxation term: affects the charging and discharging of capacitors.

Capacitors need to be grounded if not used



Ideal capacitor w/o R, L. $L=0$ for switch is assumed. $T=RC=0$

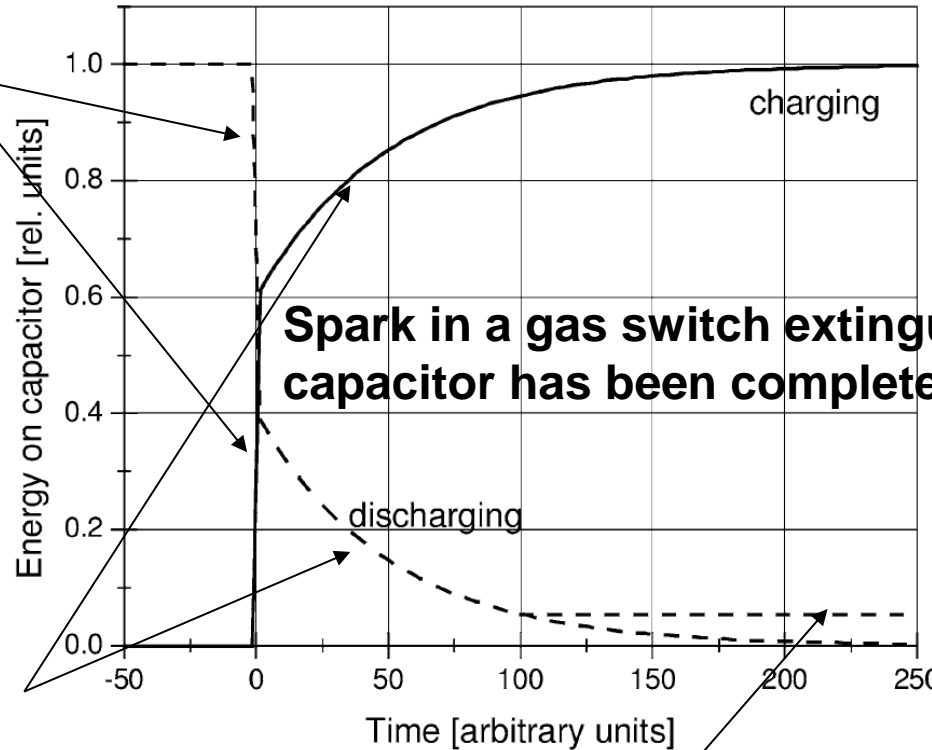

Spark in a gas switch extinguishes before the capacitor has been completely discharged.

Polarization continue to relax to the static value.

Self-generated

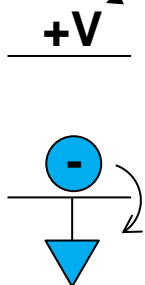
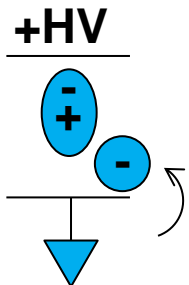

If capacitor is not grounded continuously, electron previously had penetrated into the dielectric may diffuse out and recharge the capacitor.

Operation frequency needs to be away from the self-resonant frequency of the capacitor



- **Complex impedance of a capacitor:**

$$Z = R_{\text{esr}} + i \left(\omega L - \frac{1}{\omega C} \right)$$

$R_{\text{esr}} \approx R_S$ **Equivalent series resistance**

$$\omega_r L - \frac{1}{\omega_r C} = 0 \Rightarrow \omega_r = \frac{1}{\sqrt{LC}}, Z = R_{\text{esr}}$$

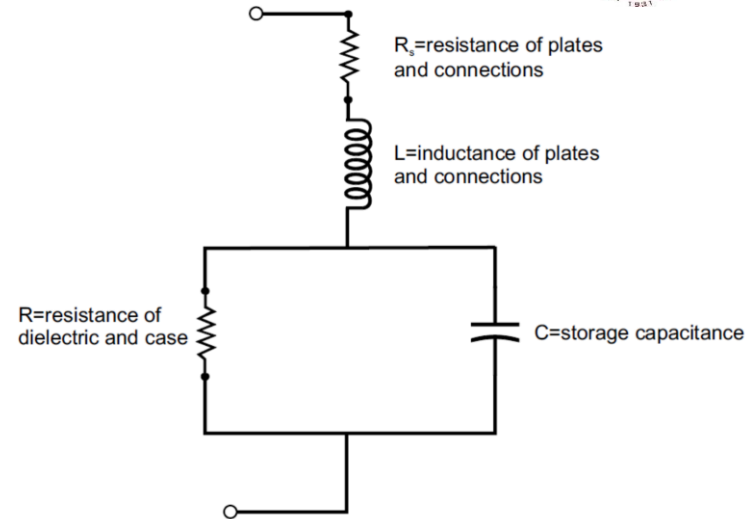

- In general, operational frequency $\omega \ll \omega_r$ to avoid large power losses inside the capacitor and destroy it.
- A fast capacitor requires stacks with a short path to the terminal.

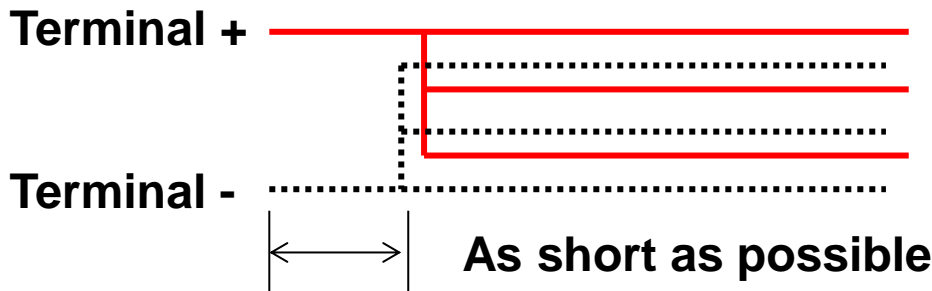

Capacitor lifetime can be affected strongly by the voltage reversal and charged voltage

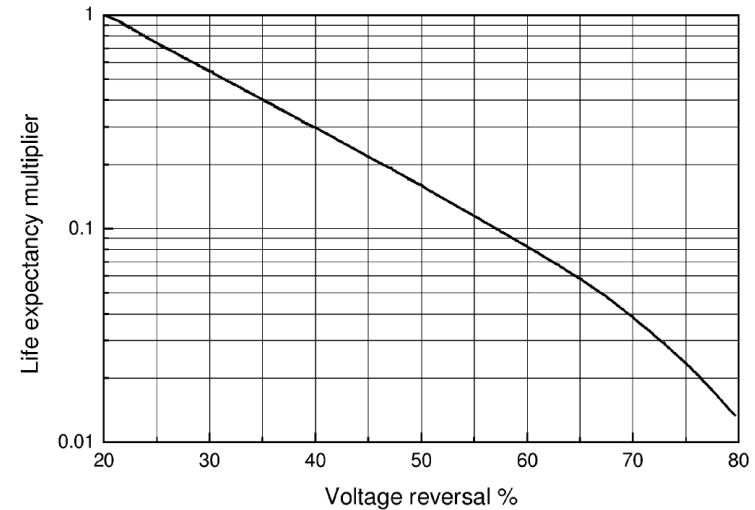
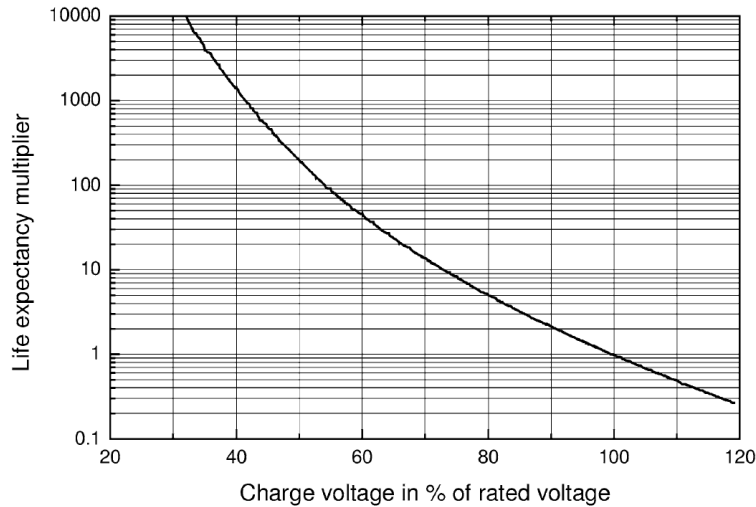

- **If charge has been injected from the metallic-cathode side into the dielectric, the space charge field associated with it can add to the external field during voltage reversal and the total field can exceed the local breakdown stress and cause damage to the material.**

It takes time for dipole to rotate

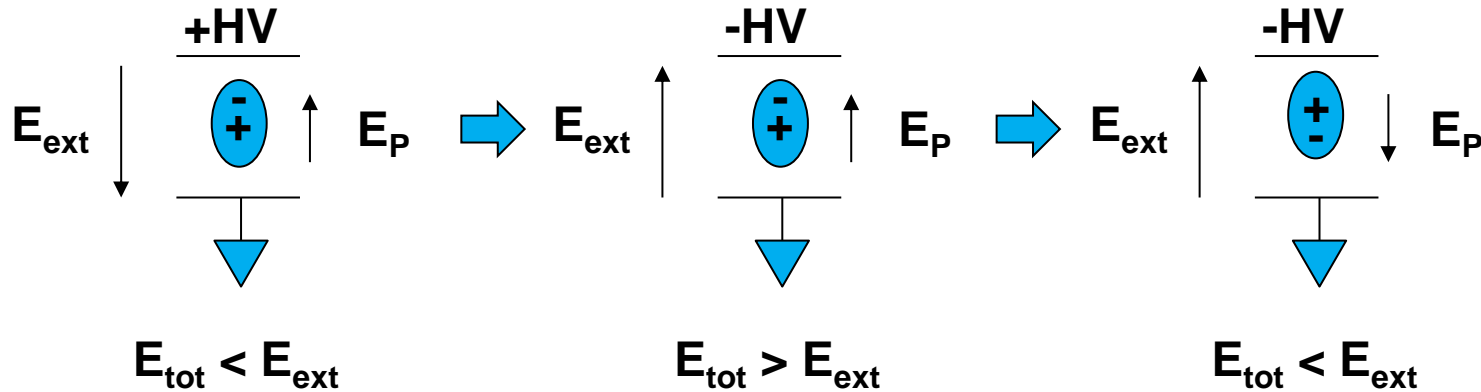

- It takes time for dipole to rotate. E_p is in the same direction to E_{ext} in a short period of time.
- To extend life time ($>10^8$ shot for industrial uses):
 - $V \ll V_{\text{rate}}$
 - Very conservative dielectric insulation, i.e., large size and low energy density.

Failures in capacitors



- **Surface tracking along the insulating margin at the edges of capacitor sections.**
 - **Eliminated by resistively grading the field distribution at the capacitor edge.**
Achieved by impregnating the paper with a dilute solution of copper sulphate in water (CuSO_4). The loss current increases and the hold time reduces.

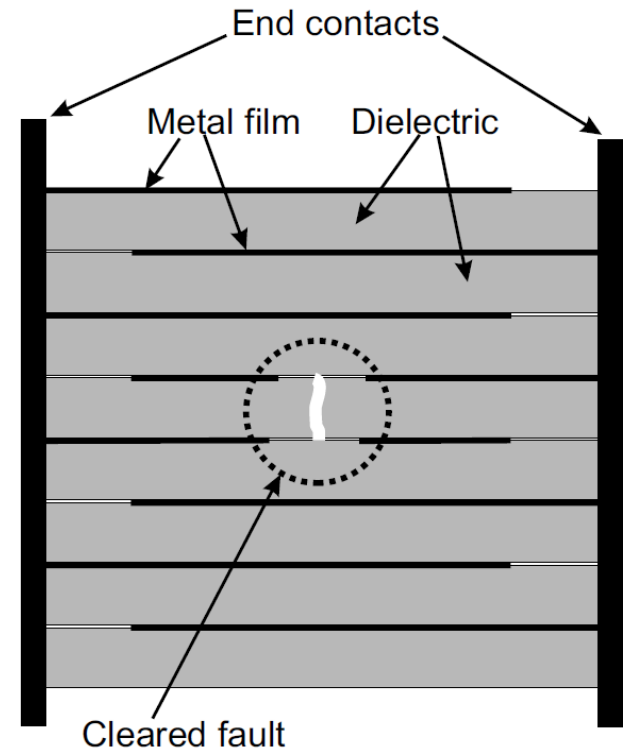

Failures in capacitors



- **Breakdown at voids or impurities in the dielectric.**
 - Breakdown may not destroy the capacitor due to the “self-cleaning” process.
- **Arcing at pressure-contacted tabs or in other sections of the capacitor.**
 - It produces gasification of materials and pressure increases.
 - Avoided if all contacts are soldered or welded.

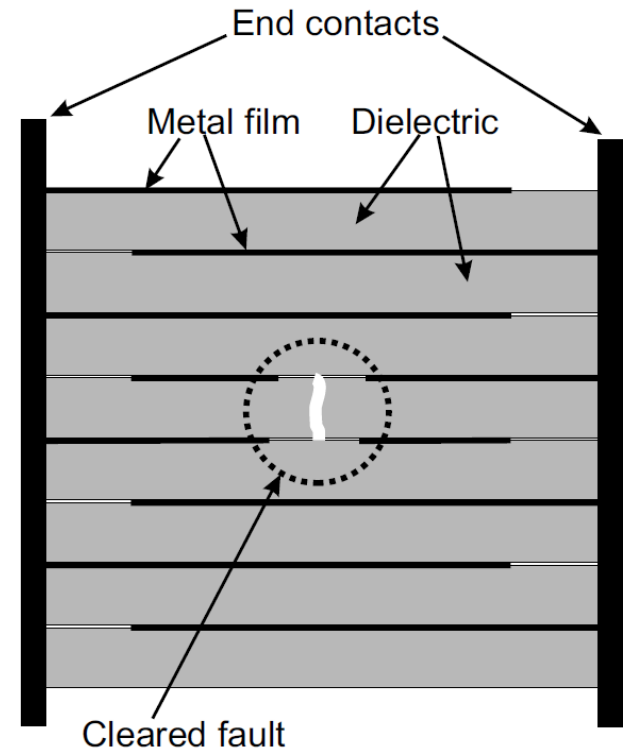

Outlines



- Introduction to pulsed-power system
- Review of circuit analysis
- Static and dynamic breakdown strength of dielectric materials
 - Gas – Townsend discharge (avalanche breakdown), Paschen's curve
 - Liquid
 - Solid
- **Energy storage**
 - Pulse discharge capacitors
 - **Marx generators**
 - Inductive energy storage

Marx generators



- HV pulse capacitors – operation voltage < 100 kV.
- Transformers for high-power charging units become prohibitively large above 100 kV.
- Solution: charge several capacitors in parallel @ switch them in to a series configuration for discharge.

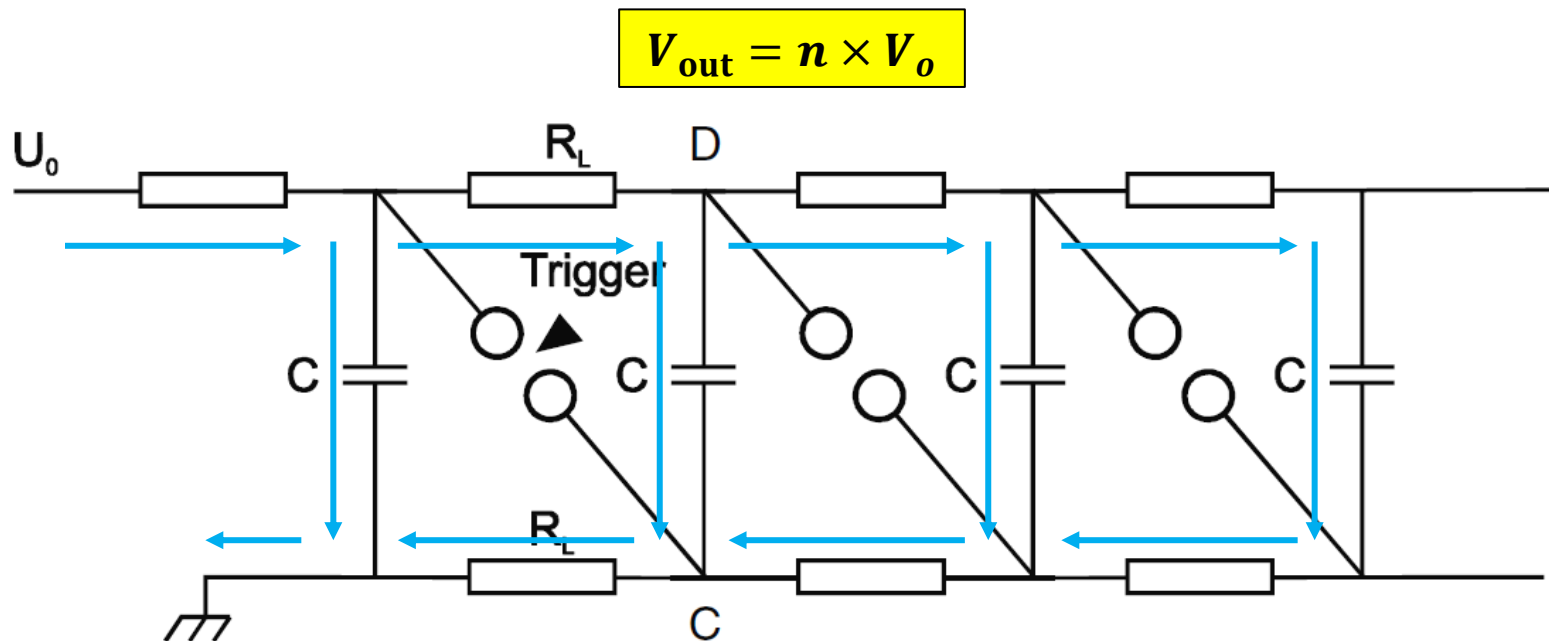

Marx generators



- HV pulse capacitors – operation voltage < 100 kV.
- Transformers for high-power charging units become prohibitively large above 100 kV.
- Solution: charge several capacitors in parallel @ switch them in to a series configuration for discharge.

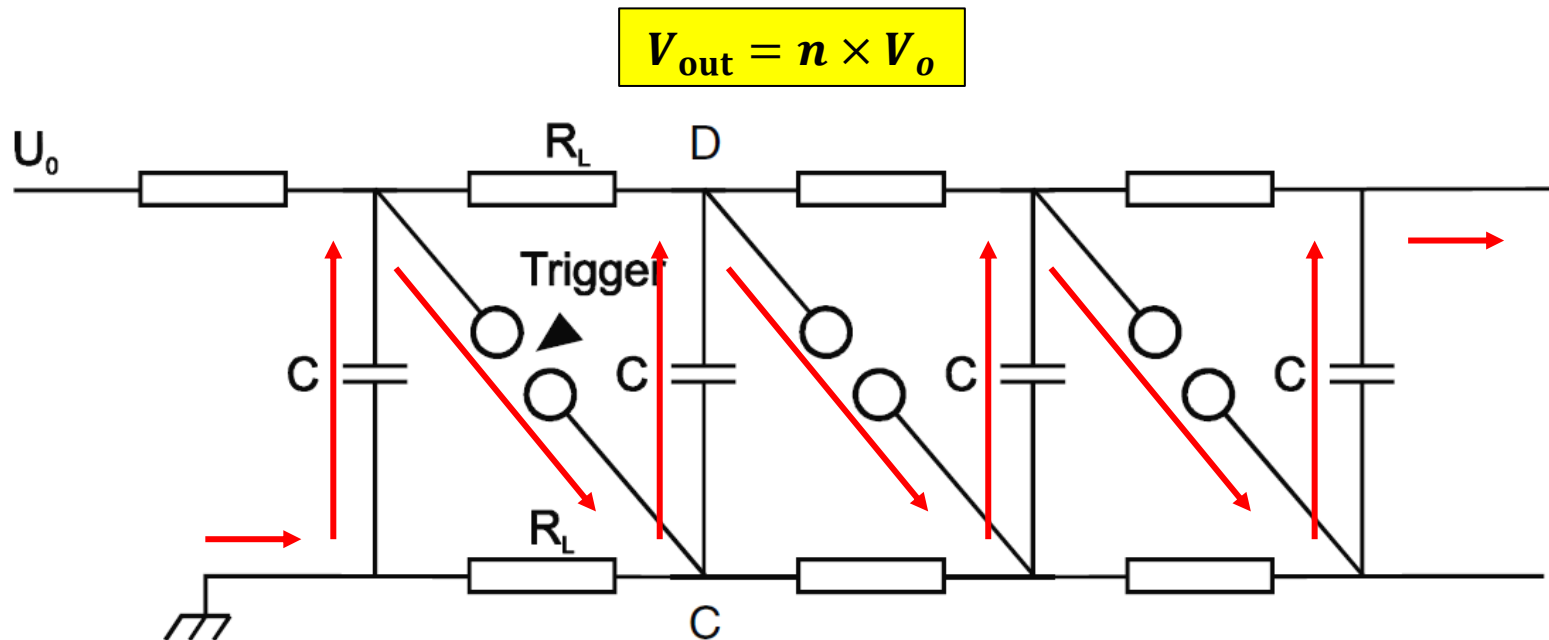

Eight-stage little Marx generator

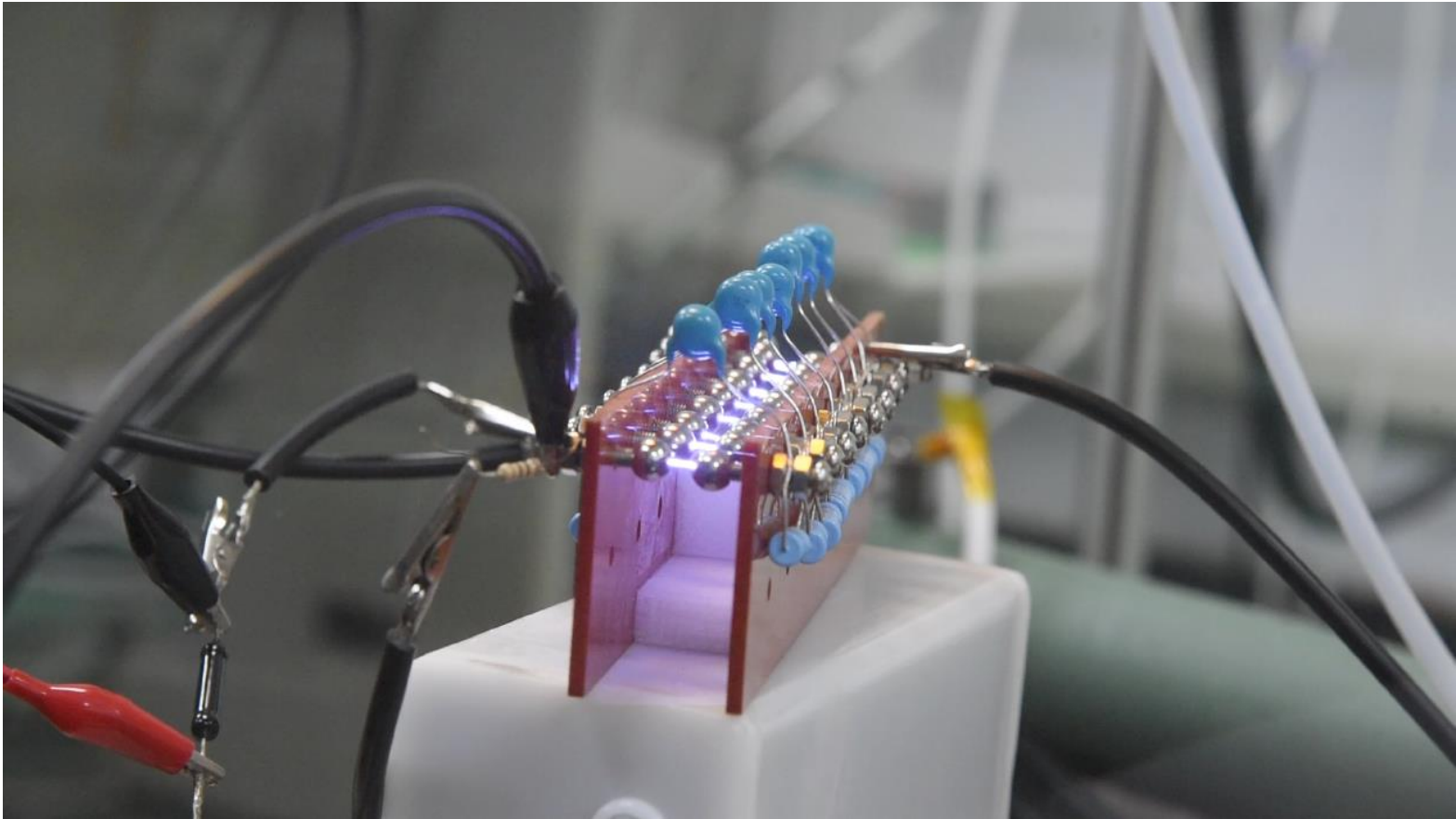

Positive vs Negative output and peaking switch

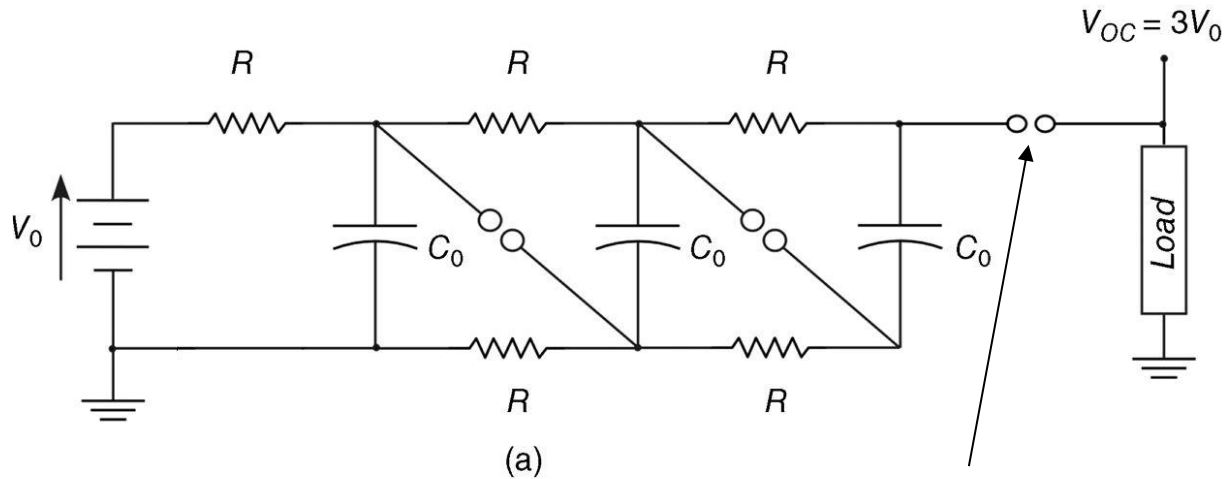

Peaking switch

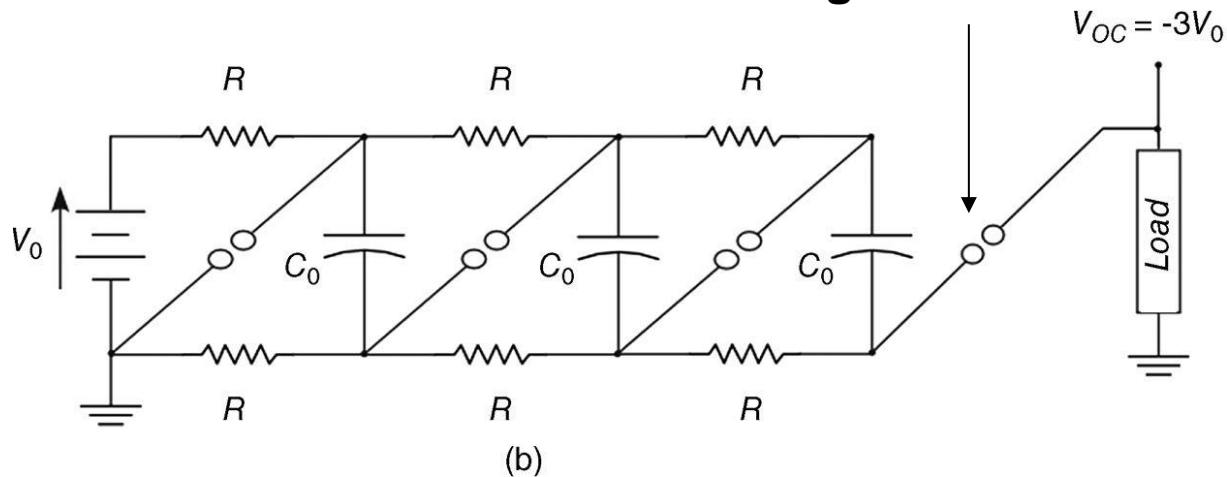

Switches are triggered sequentially



- Switch 1 is triggered and closed → point C @ U_o , point D @ $2U_o$, $\Delta V_2=2U_o$.
 → Switch 2 breakdown by itself → point E @ $2U_o$, point F @ $3U_o$, $\Delta V_3=3U_o$.
 → Switch 3 breakdown by itself → point G @ $3U_o$, point H @ $4U_o$, $\Delta V_4=4U_o$.
 → all gaps will fire sequentially. “erected” takes $\sim \mu\text{sec}$.

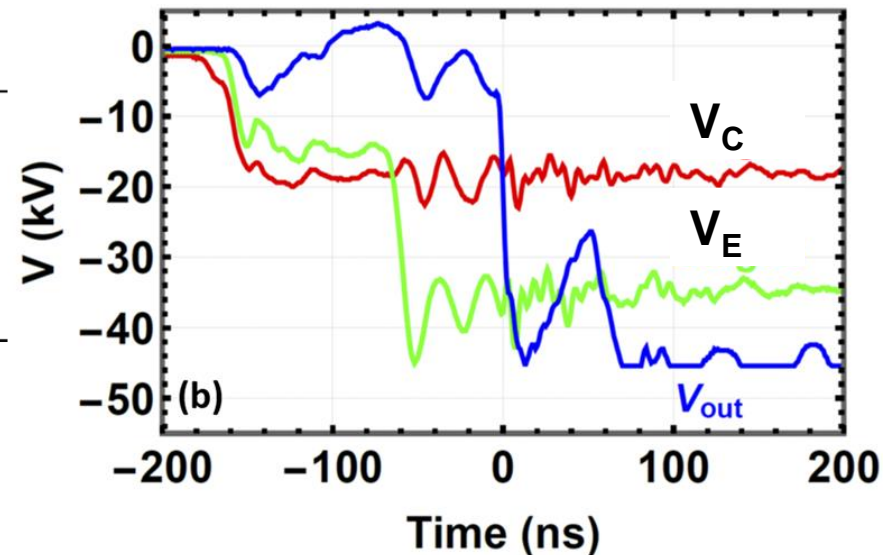
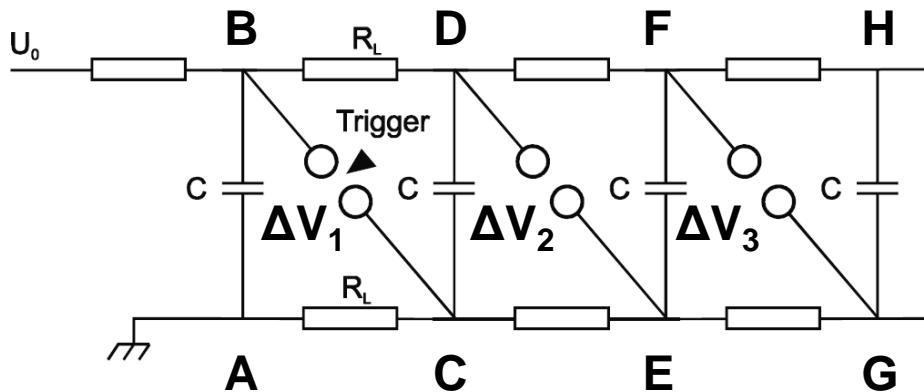

Positive vs Negative output and peaking switch

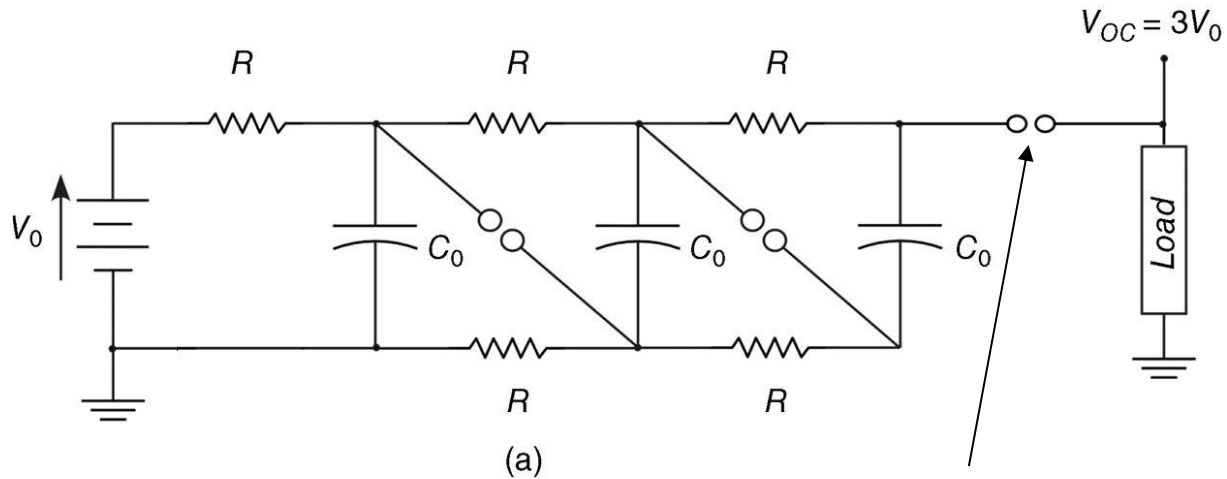

Peaking switch

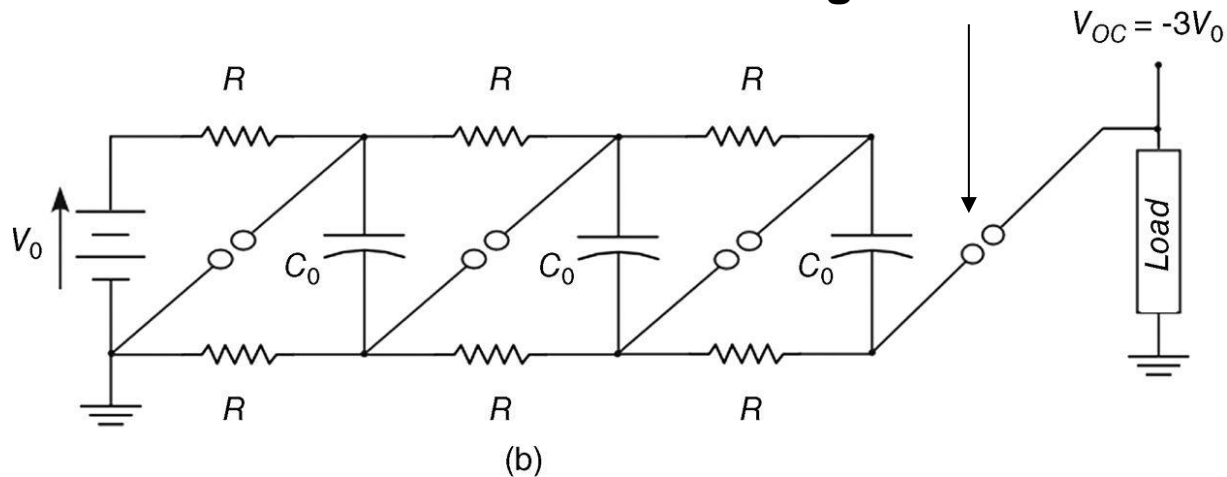

Step output of a Marx generator

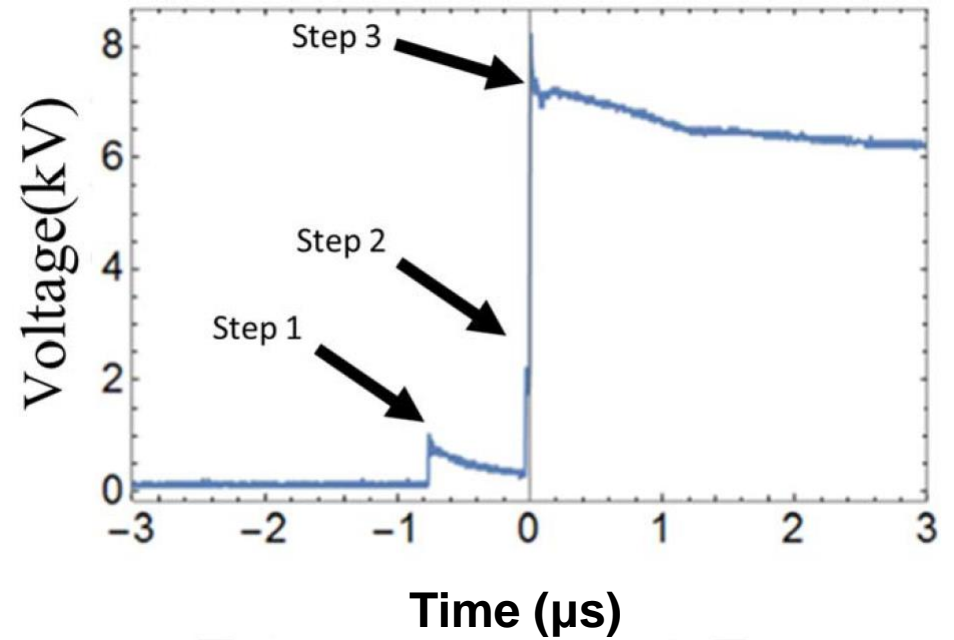
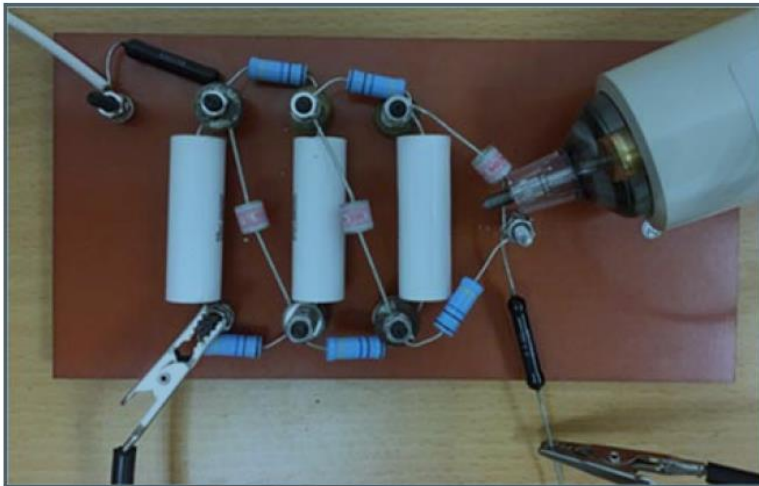

Step output is removed with using a peaking switch

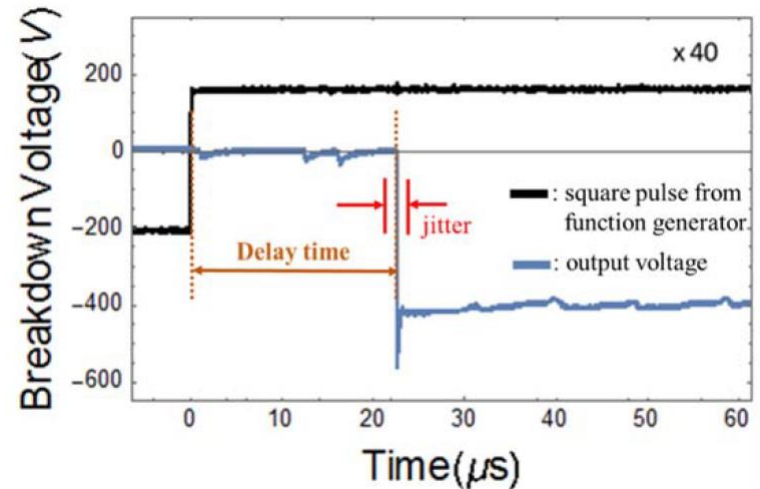
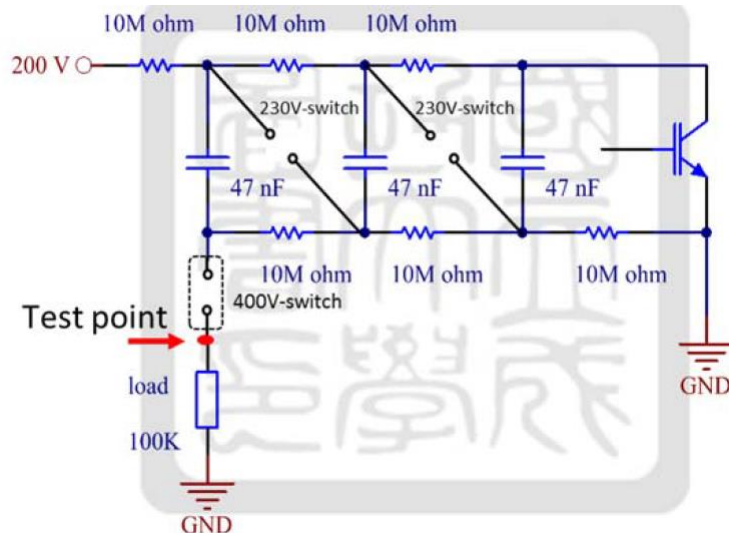
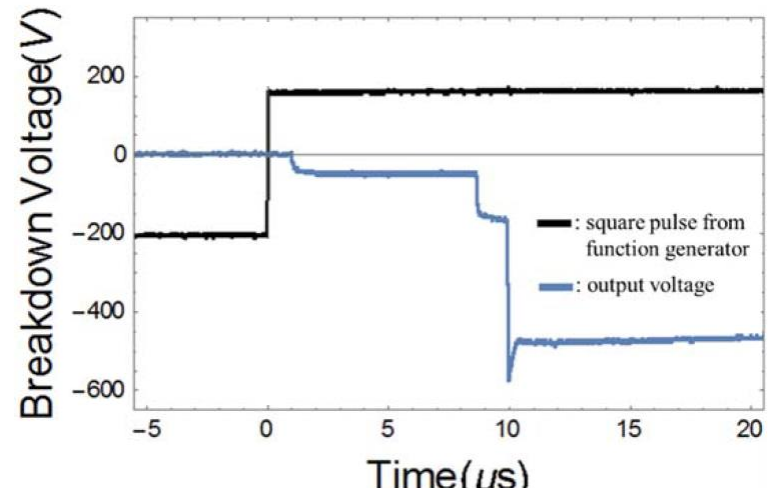
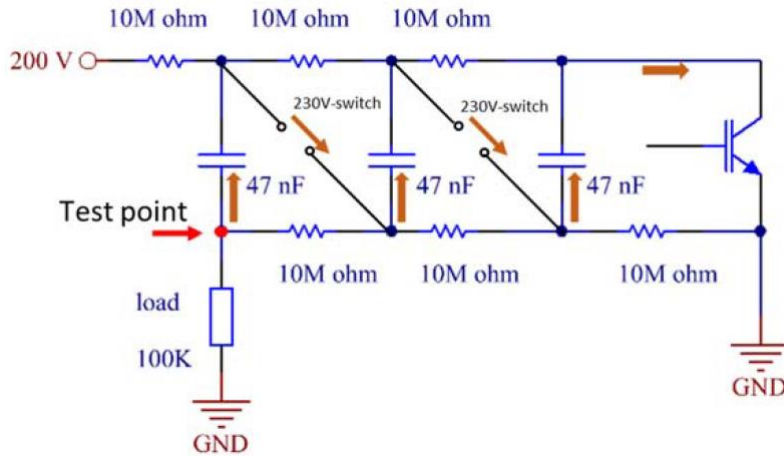

Example of the 3-stage Marx generator we built

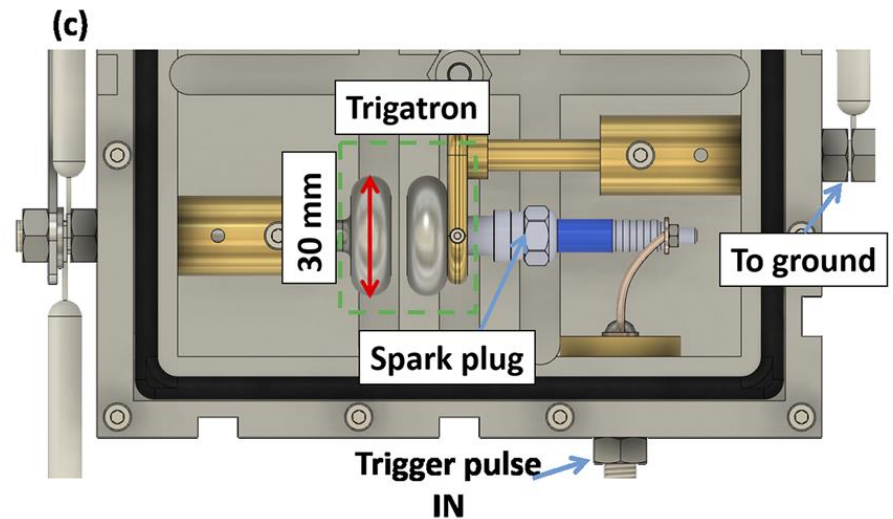
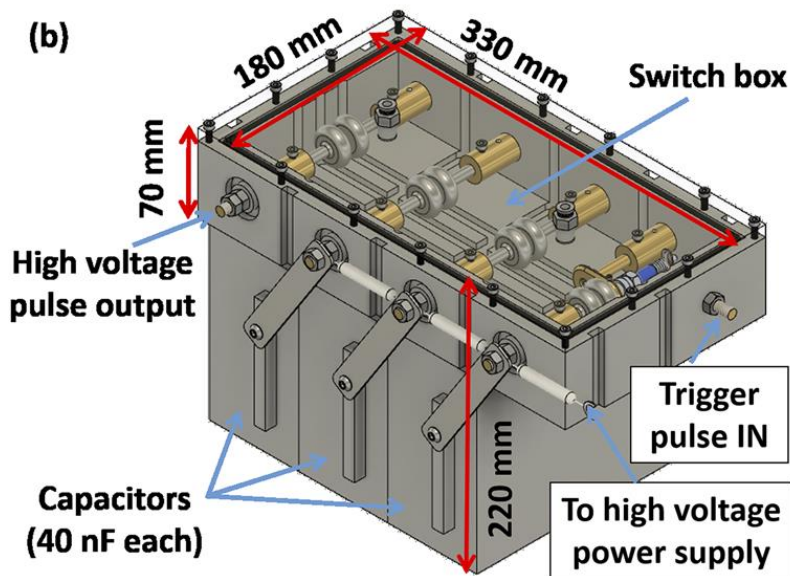
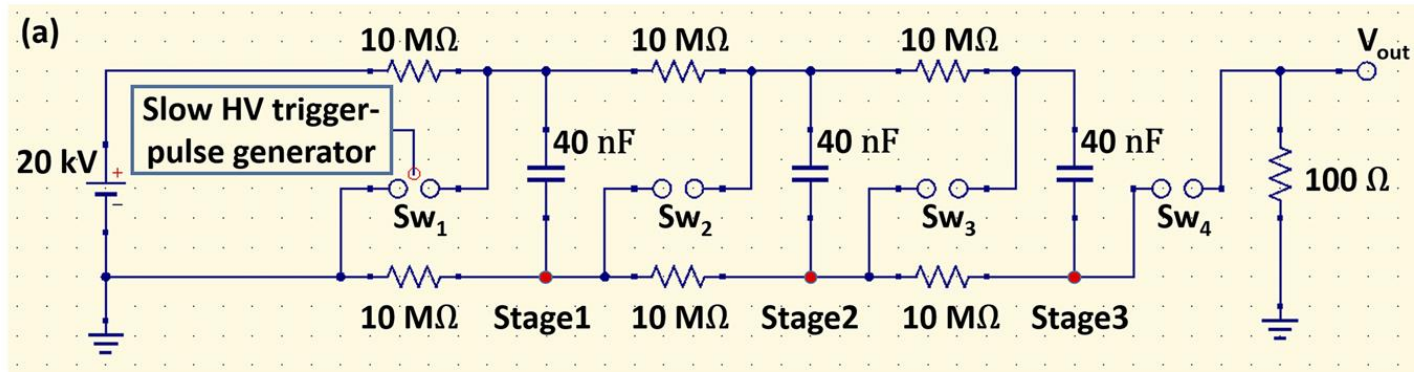

A grounding resistor is needed if a load is a “gap”

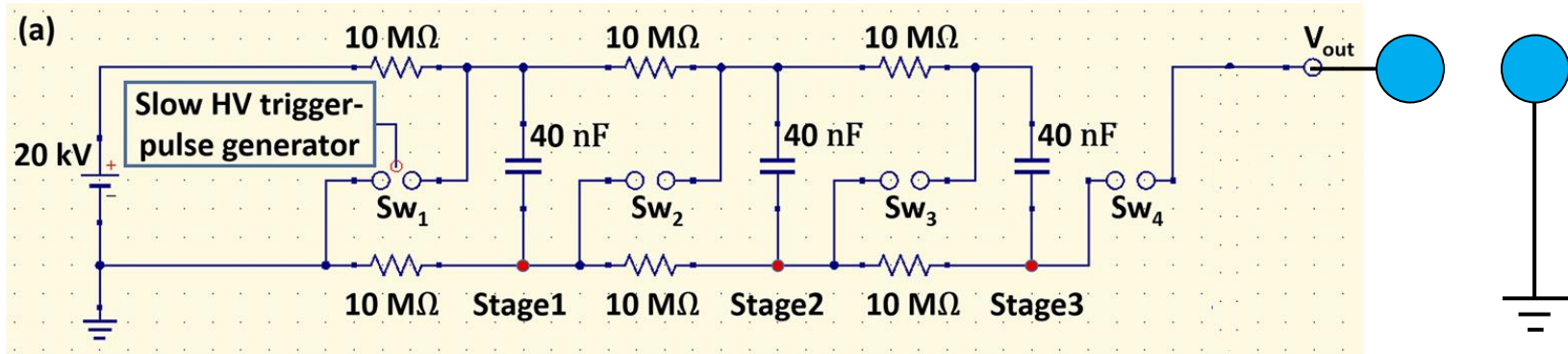
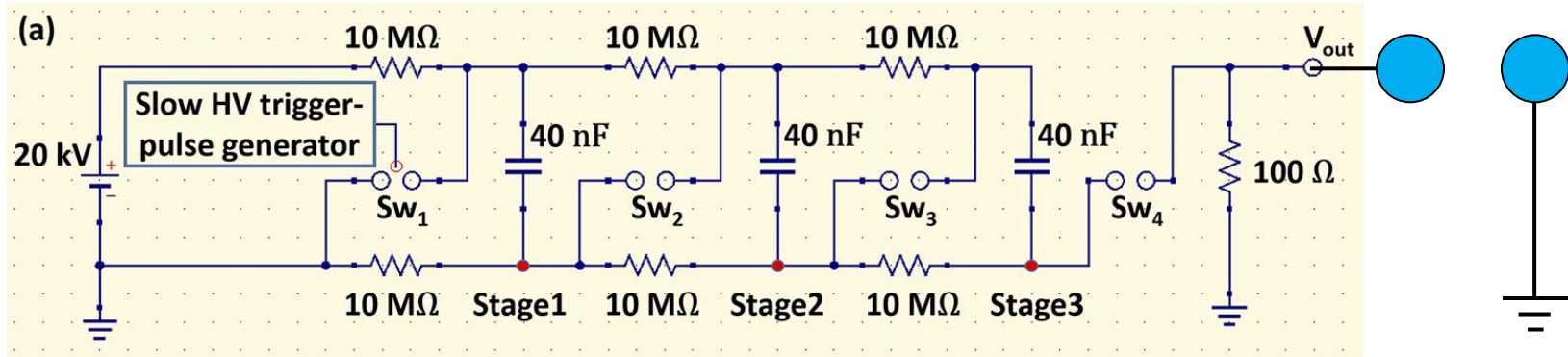

Examples of gaps as loads

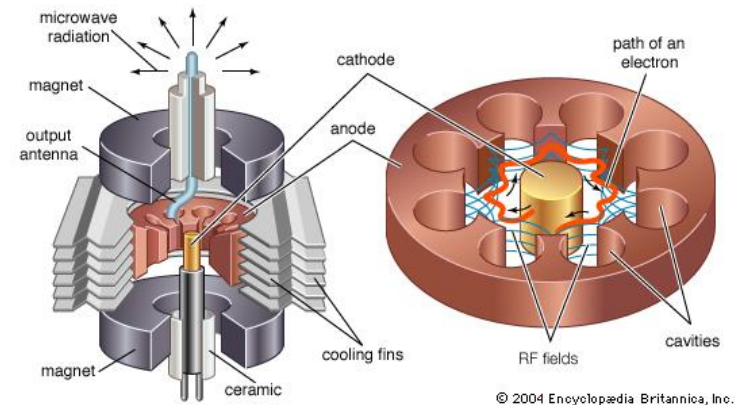
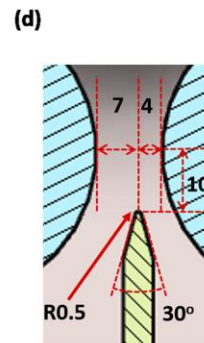
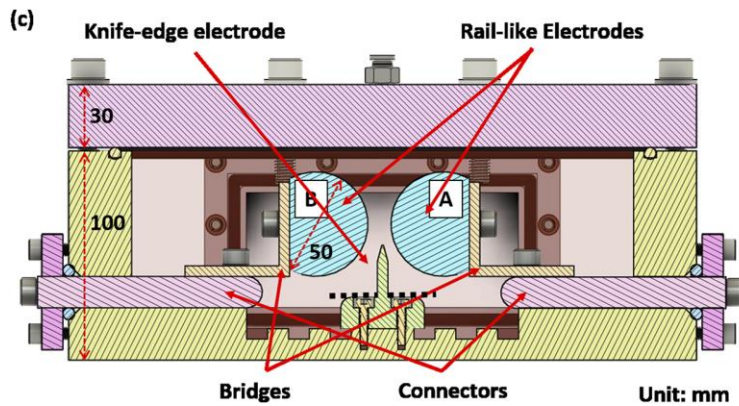
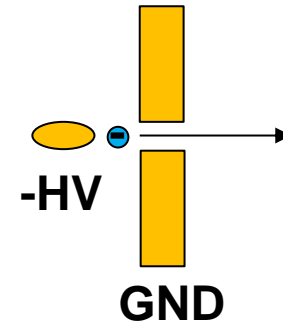
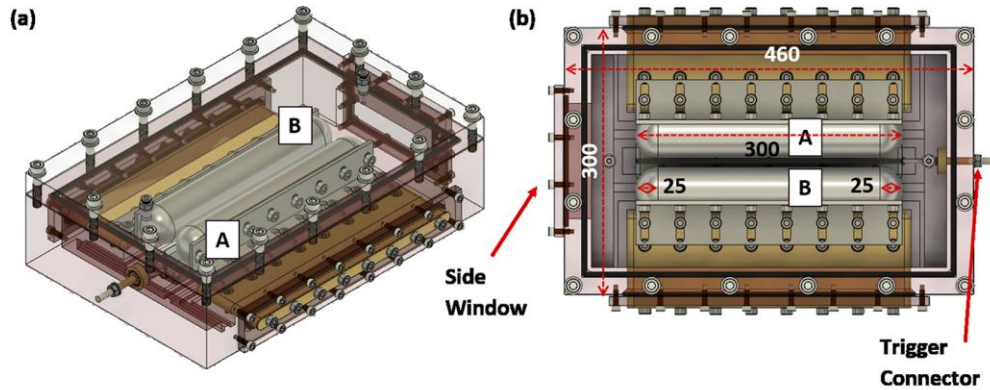

Example of the 3-stage Marx generator we built

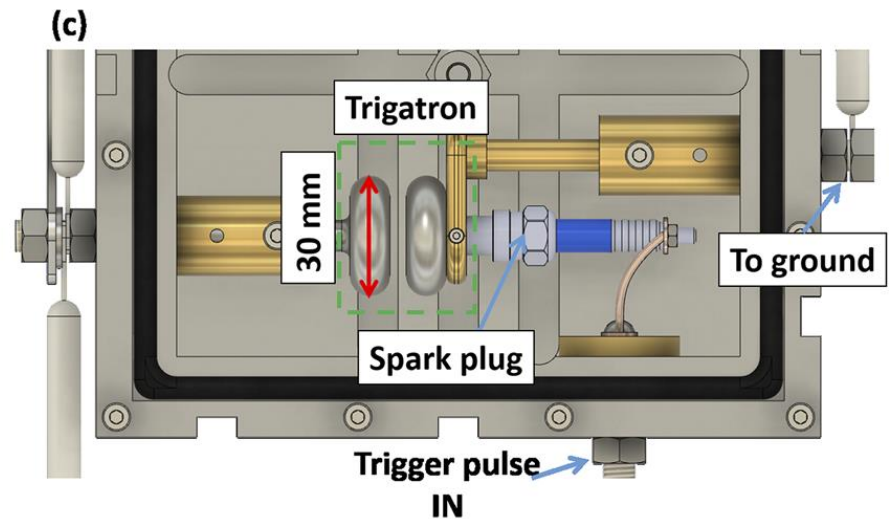
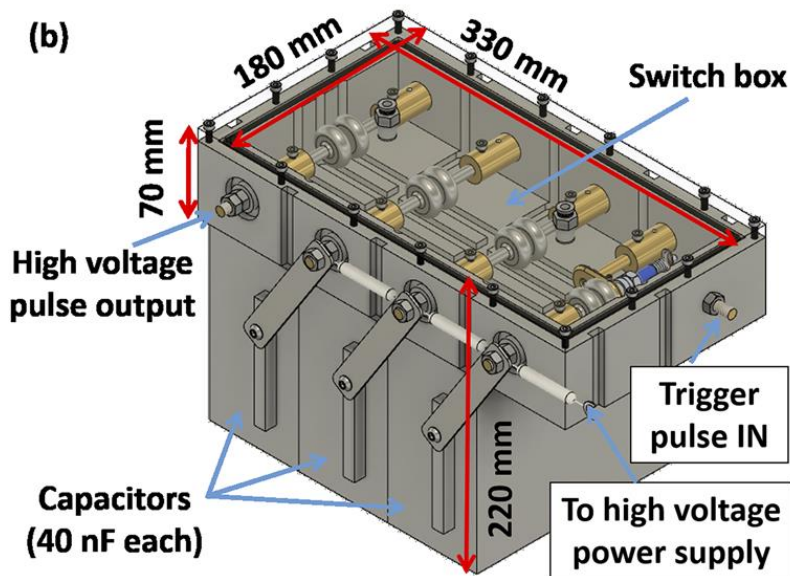
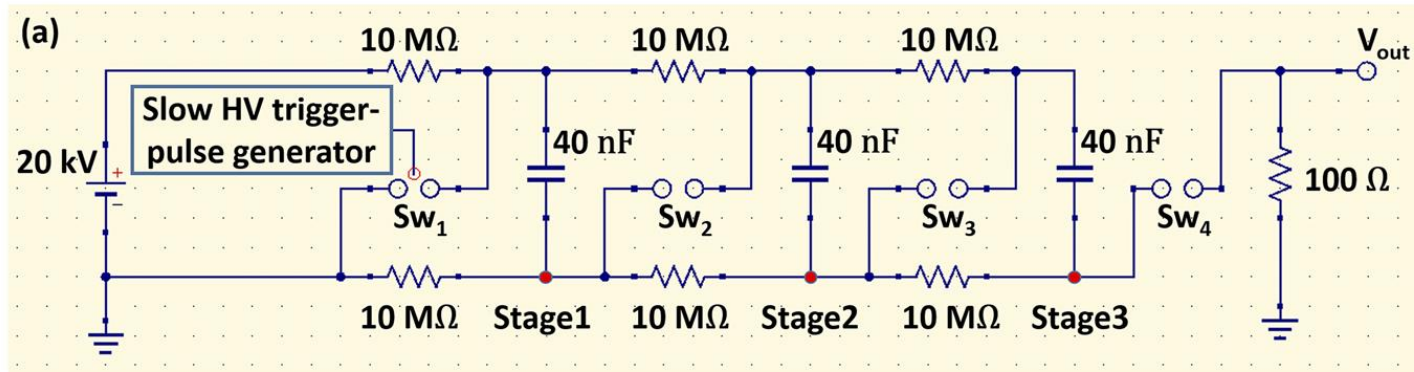

Example of the 3-stage Marx generator we built

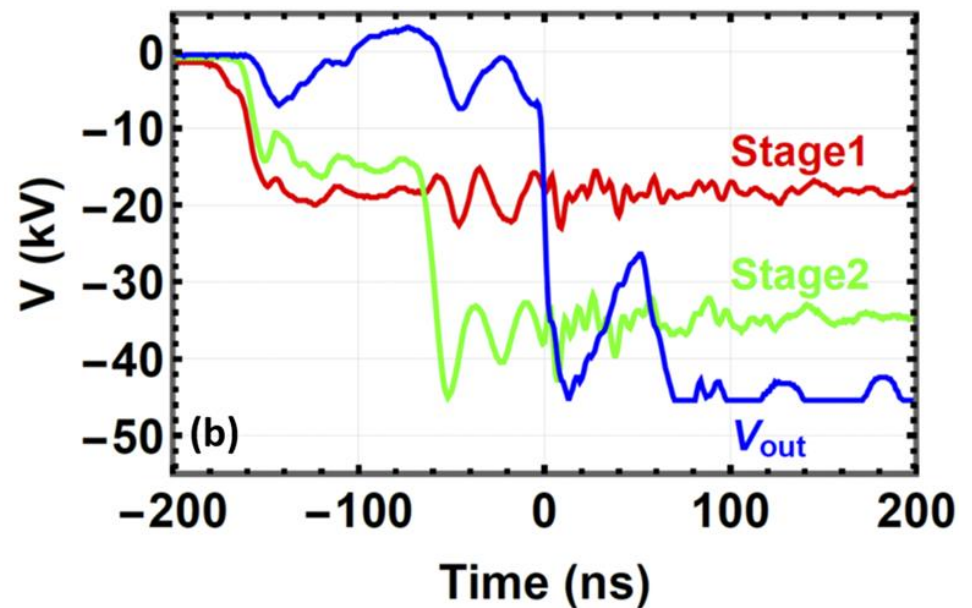
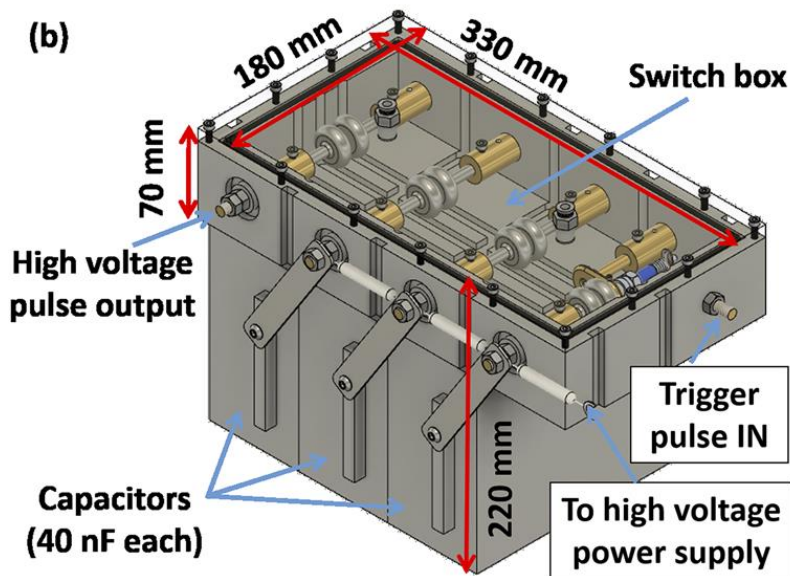
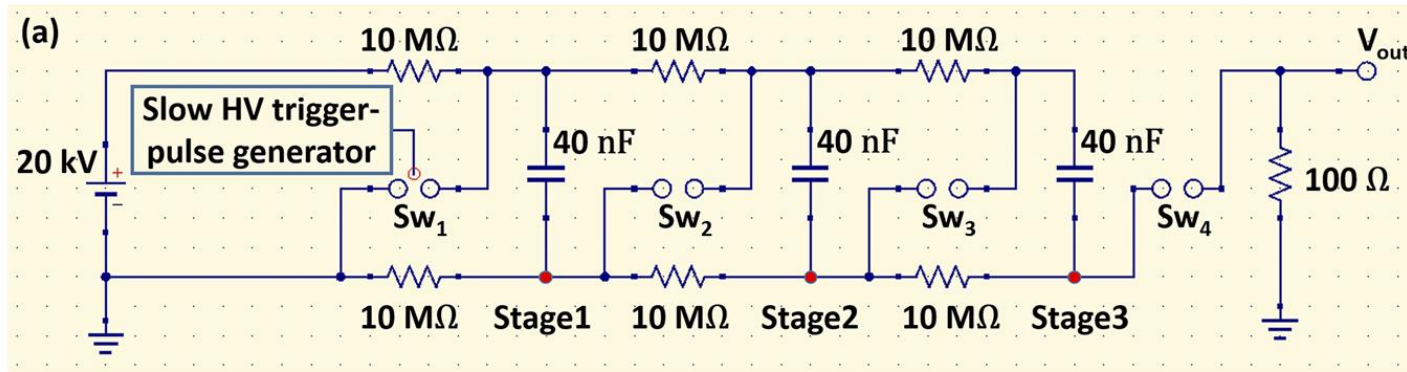

Capacitor and switch inductances need to be considered



$$C_M = \frac{C}{N}$$

$$L_M = NL_S + NL_C$$

$$E_M = \frac{N}{2} CU_o^2$$

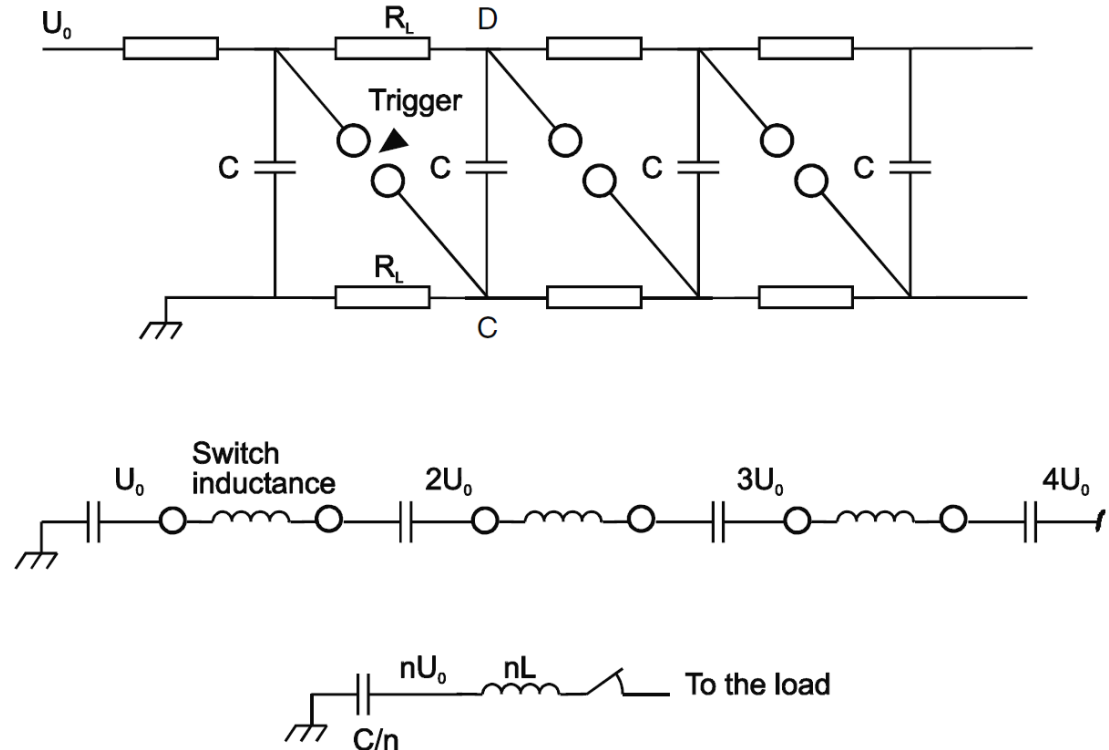

$$Z_M = \sqrt{\frac{L_M}{C_M}} = \sqrt{\frac{N(L_S + L_C)}{C/N}} = N \sqrt{\frac{L_S + L_C}{C}}$$

Bipolar-Charging Marx generator

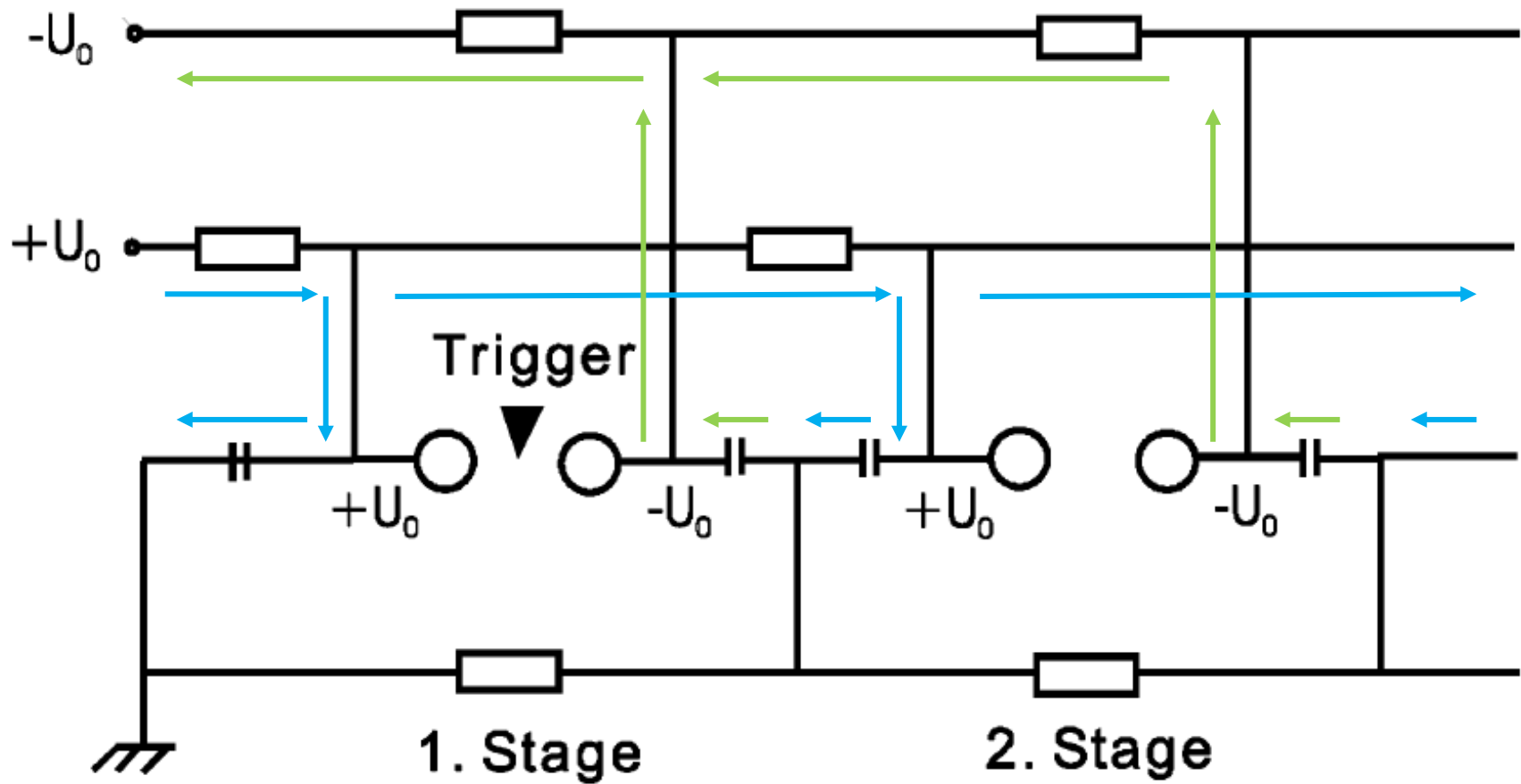

Bipolar-Charging Marx generator @ charging

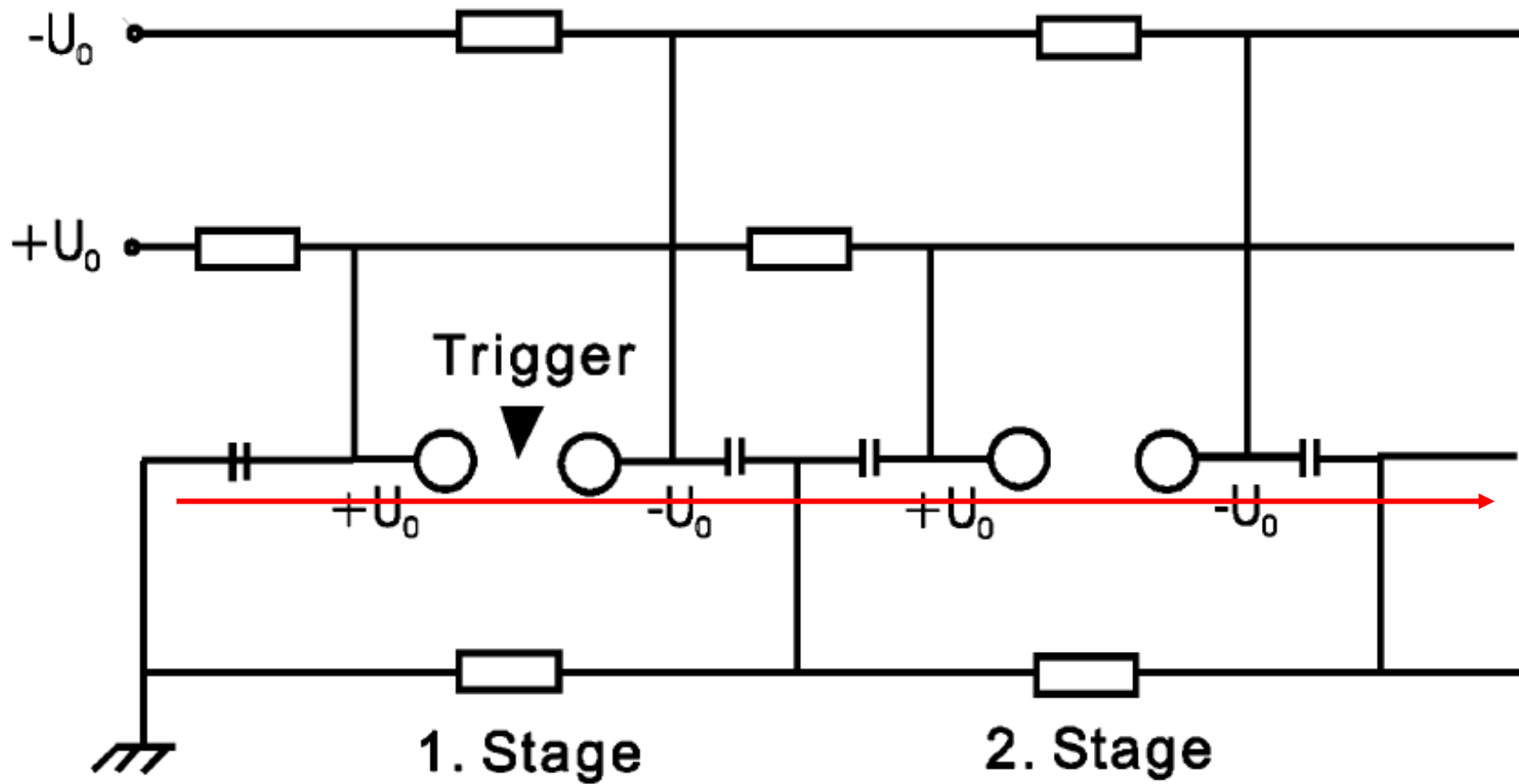

Bipolar-Charging Marx generator @ discharging



$$C_{\text{BM}} = \frac{C}{2N}$$

$$L_{\text{BM}} = NL_S + 2NL_C$$

$$E_{\text{BM}} = 2N \times \frac{1}{2} CU_0^2 = NCU_0^2$$

$$Z_{\text{BM}} = \sqrt{\frac{L_{\text{BM}}}{C_{\text{BM}}}} = \sqrt{\frac{N(L_S + 2L_C)}{C/2N}}$$

$$= N \sqrt{\frac{2(2L_C + L_S)}{C}}$$

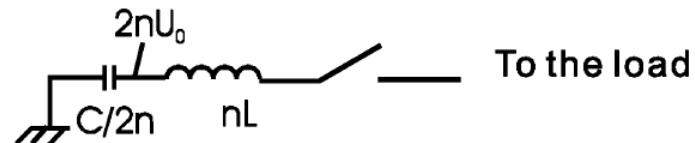
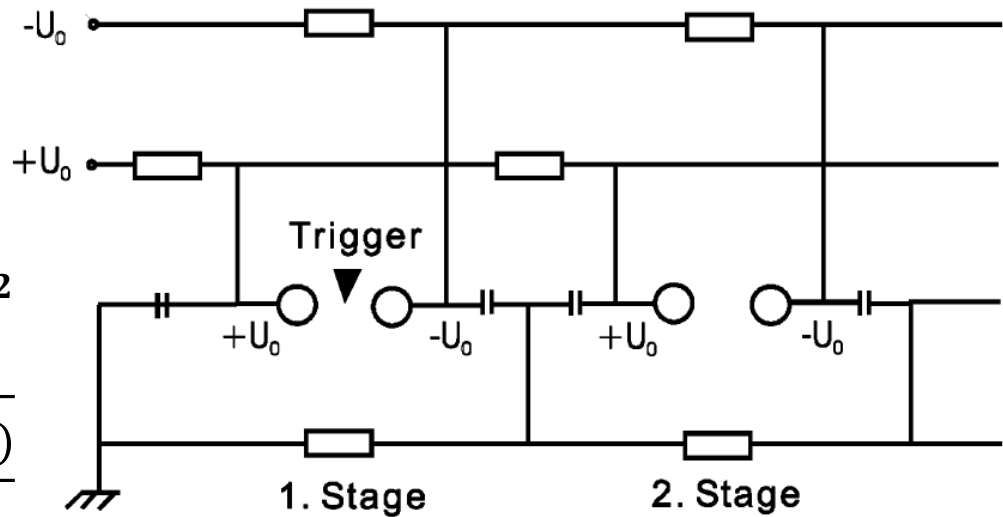

Bipolar-Charging Marx generator has a smaller impedance than a conventional Marx generator



$$C_M = \frac{C}{2N} \quad L_M = 2NL_S + 2NL_C$$

$$E_M = NCU_0^2$$

$$Z_M = 2N \sqrt{\frac{L_S + L_C}{C}}$$

$$Z_{BM} = N \sqrt{\frac{2(2L_C + L_S)}{C}}$$

$$\frac{Z_{BM}}{Z_M} = \frac{N \sqrt{\frac{2(2L_C + L_S)}{C}}}{2N \sqrt{\frac{L_C + L_S}{C}}} = \sqrt{\frac{2L_C + L_S}{2L_C + 2L_S}} < 1$$

$$= \frac{1}{\sqrt{2}} \sqrt{\frac{1 + 2L_C/L_S}{1 + L_C/L_S}} \approx \frac{1}{\sqrt{2}} \quad \text{for } \frac{L_C}{L_S} \ll 1$$

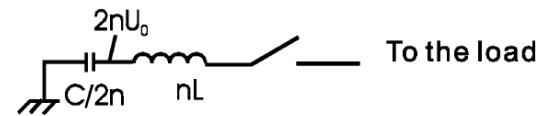
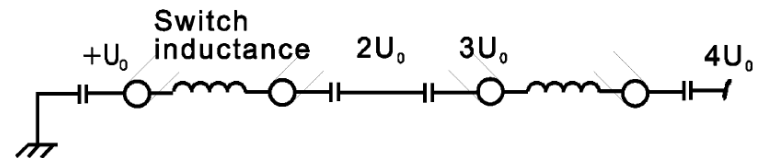
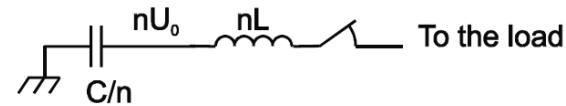
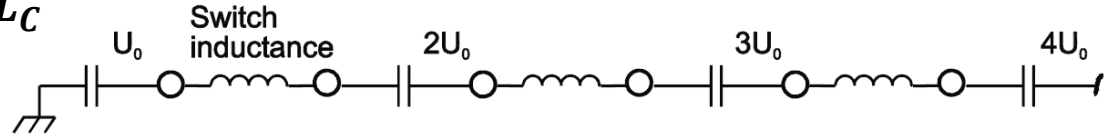

It's harder to raise the power of Marx generators to more than Terawatt



- Smaller impedance $Z_M \rightarrow$ larger power output
 - $\rightarrow N \uparrow \Rightarrow Z_M \uparrow$
 - $\rightarrow N \uparrow \Rightarrow$ longer system $\Rightarrow L_{\text{stray}} \uparrow \Rightarrow P \downarrow \Rightarrow$ more and more difficult to raise the power of Marx generators to \geq TW.
 - \rightarrow The major task is to pulse-charge an intermediate storage (water or oil filled) capacitor.
- Breakdown strength of water is dependent on the duration of the E-field stress
 - \Rightarrow charging must happen quickly if a high energy density is to be obtained.
 - \Rightarrow To obtain complete energy transfer, $C_{\text{intermediate}} = C_M$.

Intermediate capacitors are used to increase the output power



- To achieve high energy densities and short, high-power pulses, it's more beneficial to synchronize several Marx generators of reduced pulse energy to charge one water capacitor

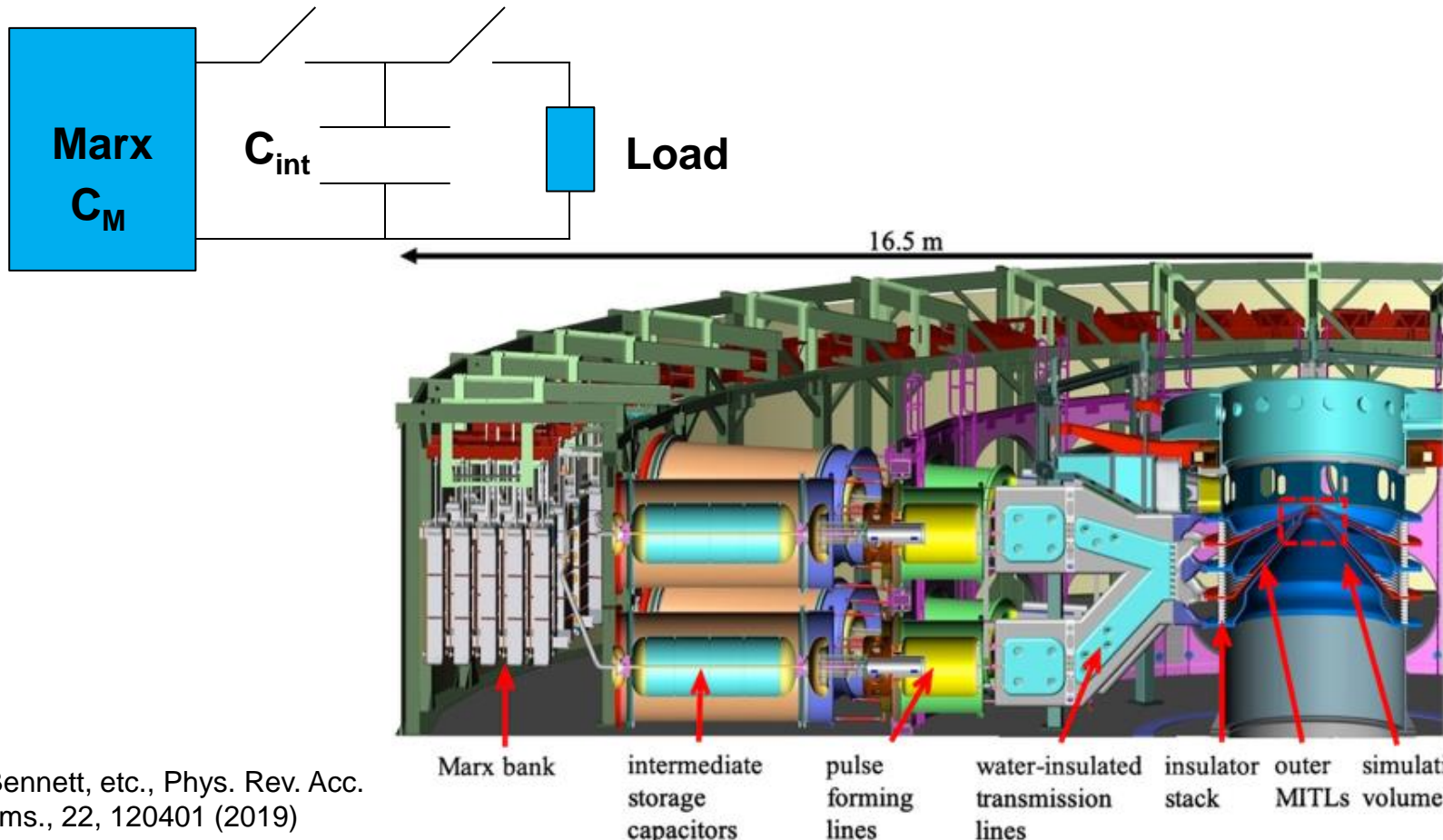

- N. Bennett, et al., Phys. Rev. Acc. Beams., 22, 120401 (2019)

Energies in capacitors are also dissipated through the charging resistors



- Each capacitor begins to discharge through two resistors in parallel with a time constant of

$$\tau_R = \frac{1}{2} R_L C_o$$

- The requirement of delivering most of the energy to the load:

$$\tau_{\text{load}} \ll \tau_R$$

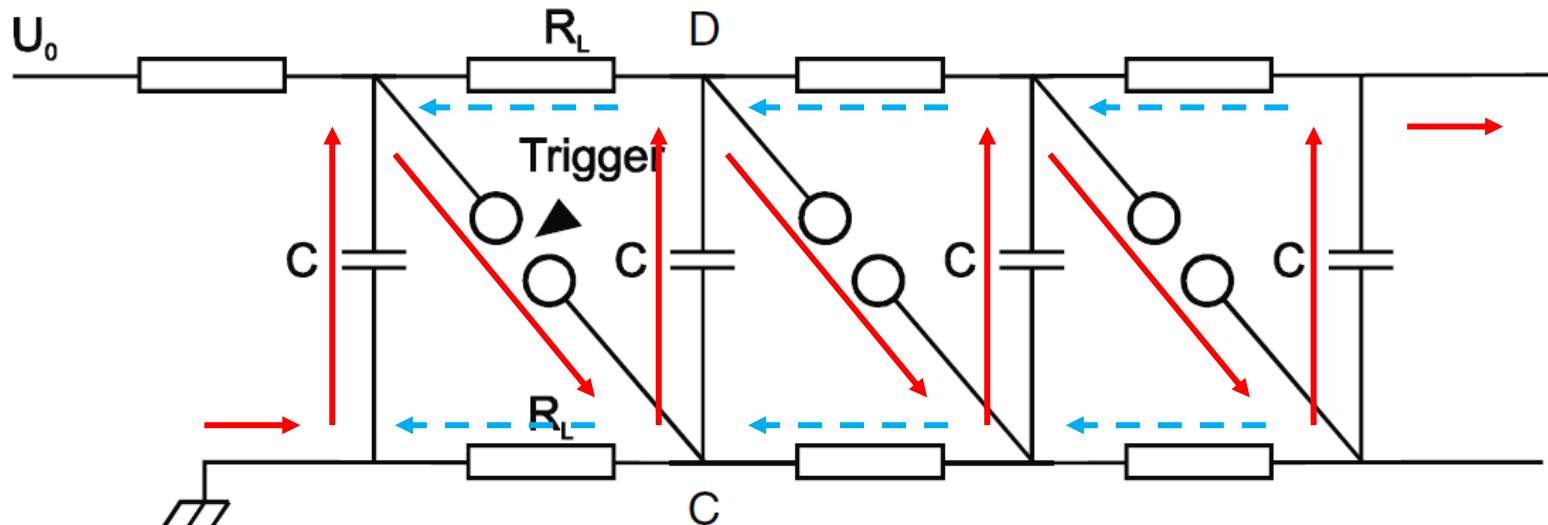

Charging resistors can be replaced by inductors



- Energy in each capacitor begins to oscillate between the capacitor and the charging inductors with a oscillation period

$$\tau_L = 2\pi \sqrt{\frac{1}{2} LC_0}$$

- The requirement of delivering most of the energy to the load:

$$\tau_{\text{load}} \ll \tau_L$$

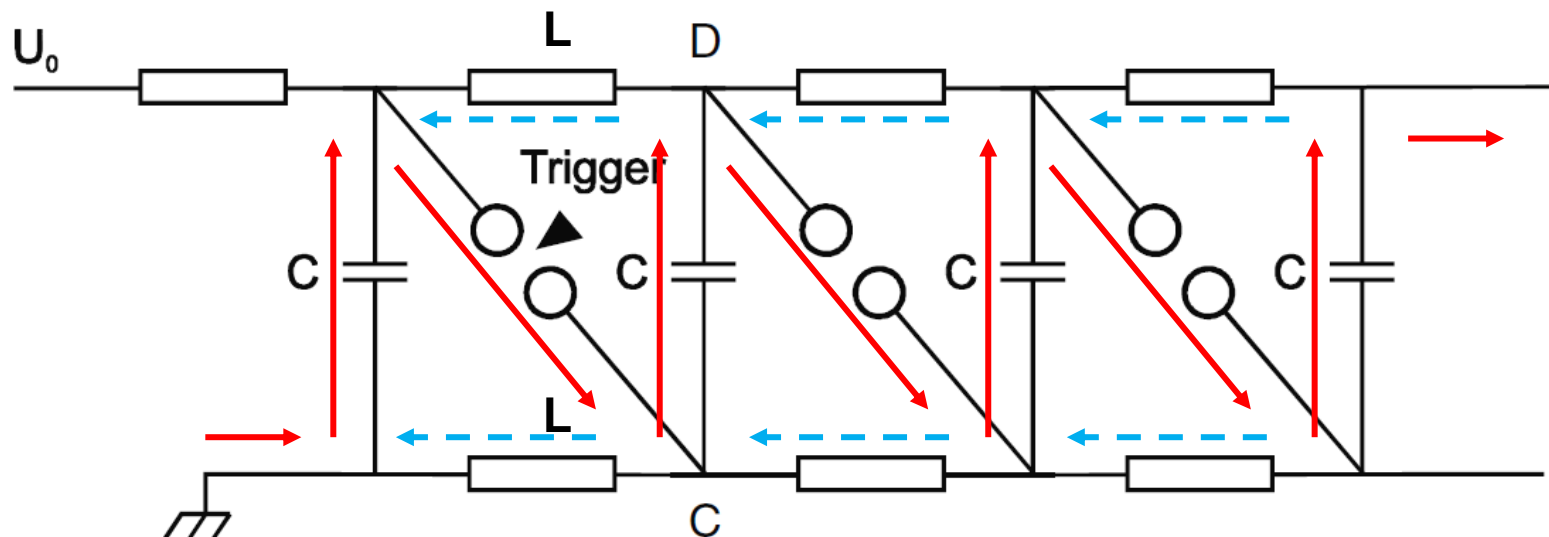

Example of using inductors for charging



- Assembly of 1kJ Marx generator



Requirements of triggering the Marx generator



- Triggering the Marx generator means starting the erosion process by external-command control at a preselected instant in time.
 - Small jitter.
 - Low prefire probability.
 - Large operating range.
- First stage – triggable three-electrode spark-gap switch.
- Later stage – self-breaking spark-gap switch.

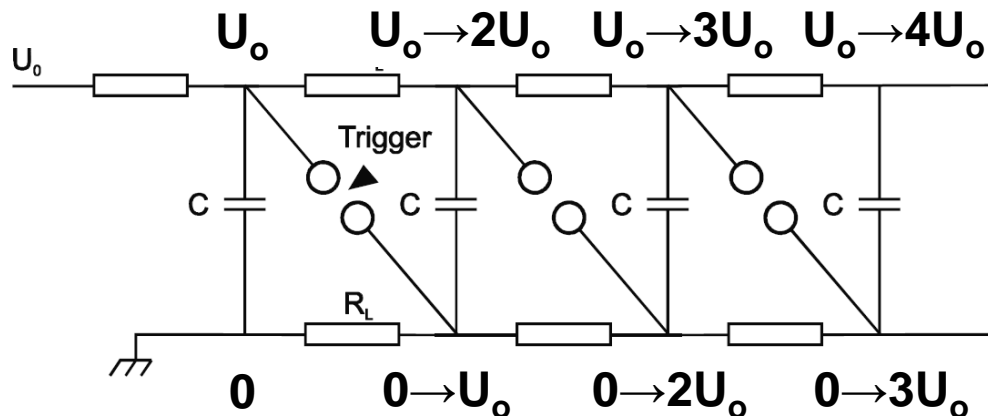

Stray capacitors needed to be considered



- **Charging cycle:**

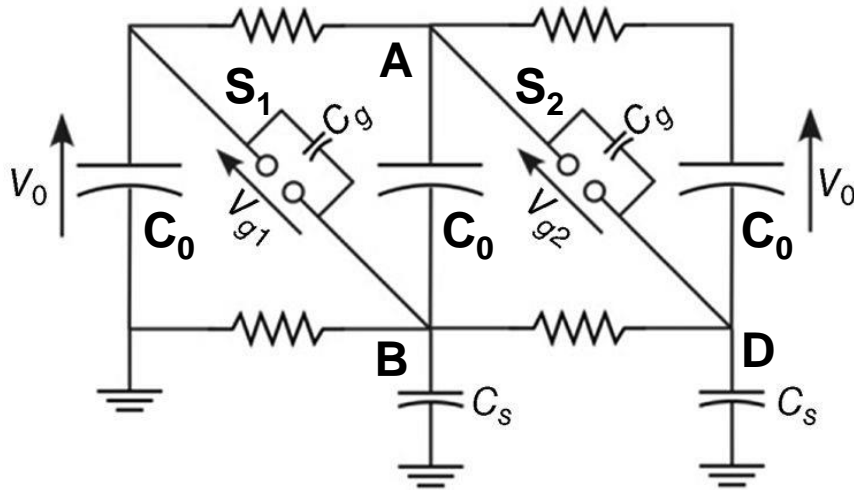

- **After the first stage has fired:**

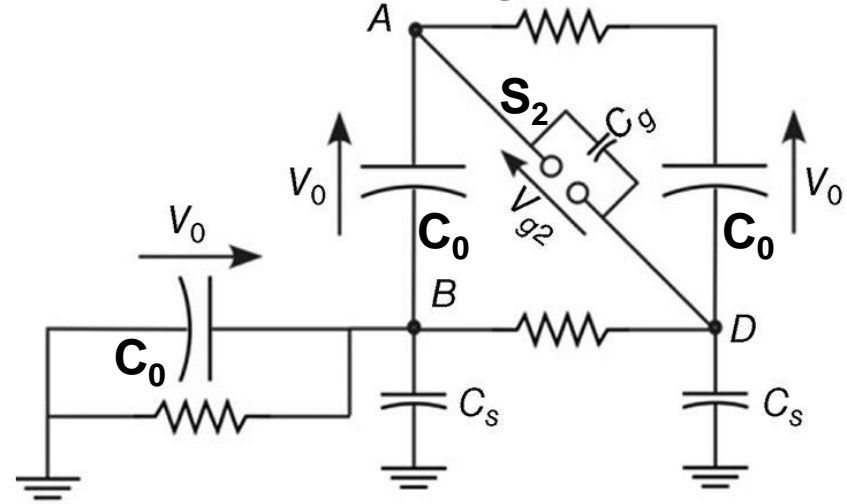

C_s : between the stage capacitors and ground.

C_g : between the switch electrodes.

- **Assumption: (1) each capacitor is charged to V_0 ; (2) S_1 is triggered first.**
 - $\Rightarrow C_s @ B$ try to hold B to ground.
 - $\Rightarrow C_0 \gg C_s$, so C_s is charged to V_0 rapidly.
 - $\Rightarrow A \rightarrow 2V_0 \Rightarrow S_2$ will fire only if it is over voltaged sufficiently long.

Stray capacitors needed to be considered



- Charging cycle:

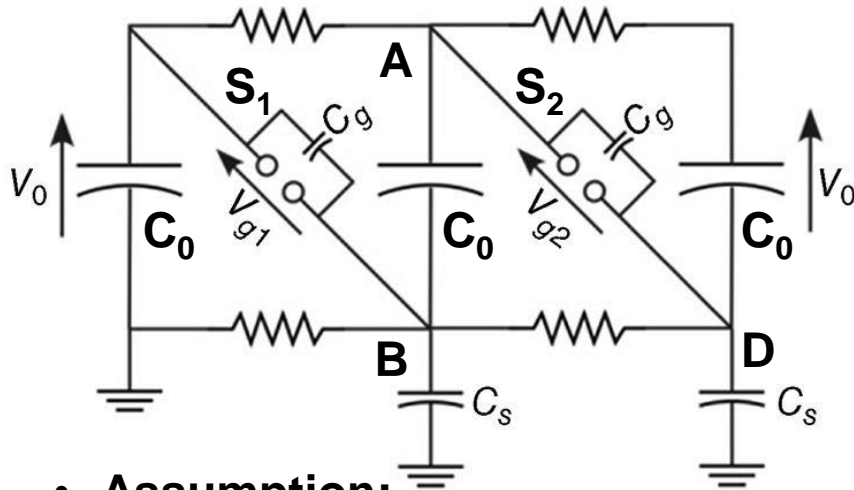

- After the first stage has fired:

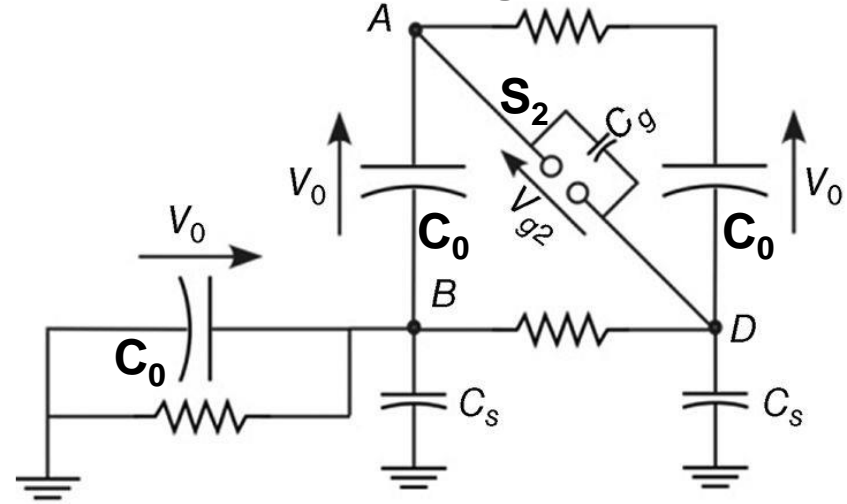

- Assumption:

$\Rightarrow A \rightarrow 2V_0 \Rightarrow S_2$ will fire only if it is overvoltaged sufficiently long.

$\Rightarrow C_g$ @ S_2 and C_s @ D form a capacitive voltage divider.

$$V_A = 2V_0 \quad V_D = 2V_0 \frac{C_g}{C_s + C_g} \quad V_{S2} = V_A - V_D = 2V_0 \frac{C_s}{C_s + C_g} = \frac{2V_0}{1 + C_g/C_s}$$

$\Rightarrow C_g/C_s$ needs to be sufficiently small.

\Rightarrow placing a ground conducting plate closed to the case of the storage capacitor.

$$C = \epsilon \frac{d}{A}$$

Stray capacitors needed to be considered



- Charging cycle:

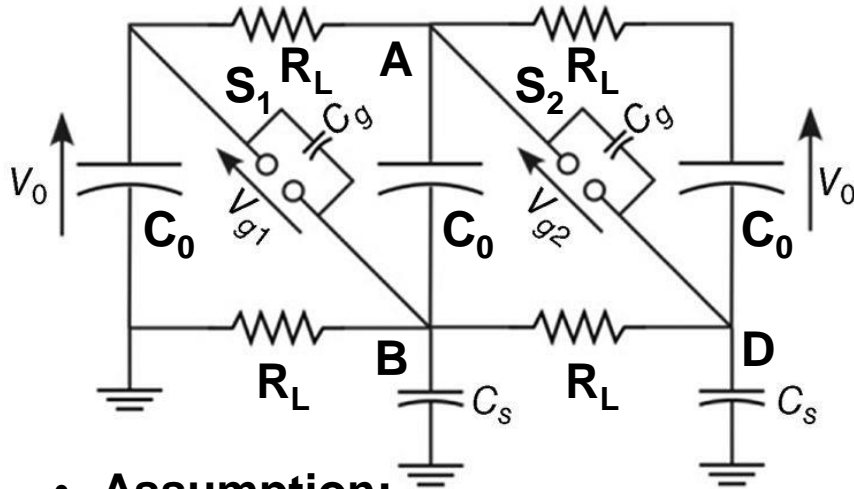

- After the first stage has fired:

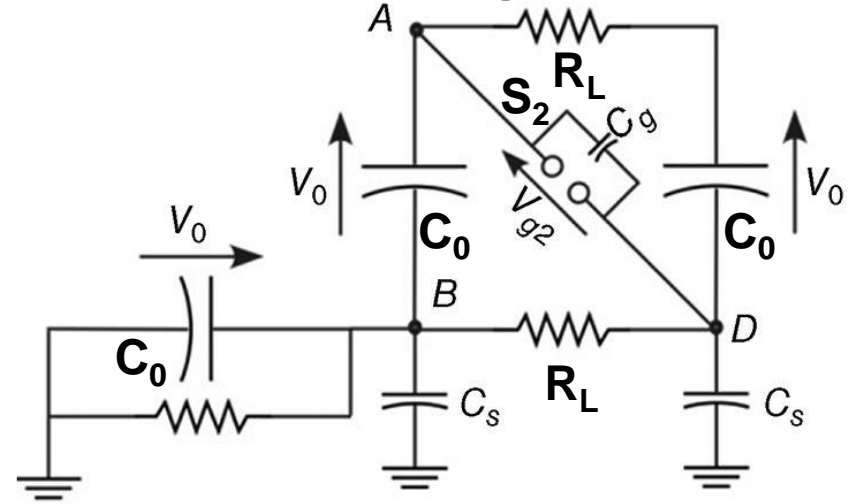

- Assumption:

$$\Rightarrow V_B = V_0 \quad V_D = 2V_0 \frac{C_g}{C_S + C_g} \approx 0 \rightarrow V_D = V_0, \text{ CS @ D is charged by } V_B \text{ through } R_L \text{ with a time constant of } \tau = \frac{1}{2} R_L C_S$$

\Rightarrow overvoltage across switch S2 drops to V_0 .

\Rightarrow breakdown at an overvoltage across each switch with a delay time less than τ is needed.

The delay between breakdown in each spark gap becomes shorter and shorter



- \therefore overvoltage becomes increasingly large,
- \therefore easier and easier to breakdown the other spark gaps.

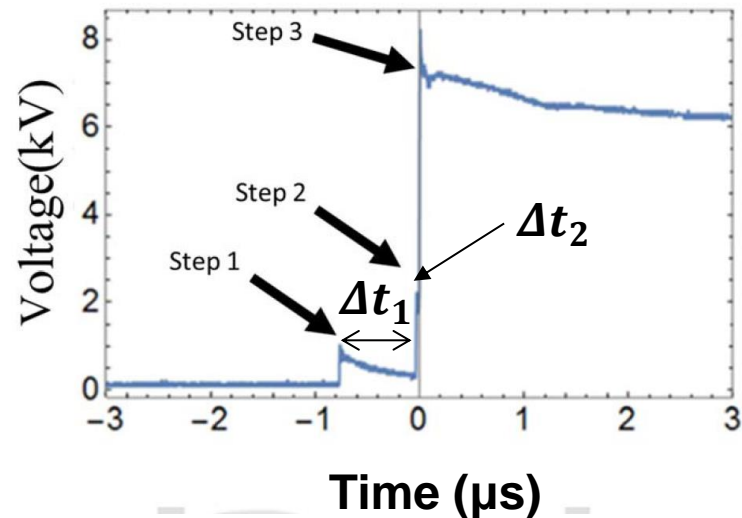
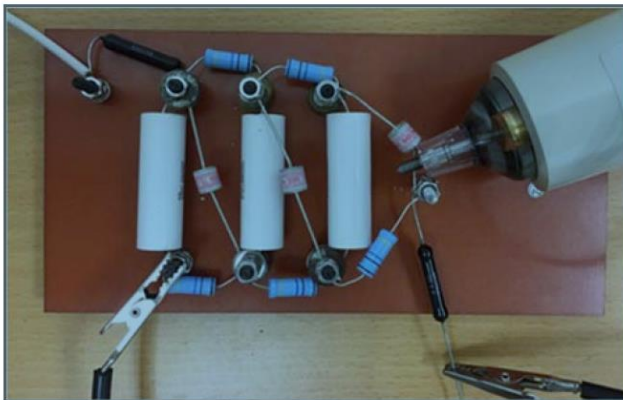
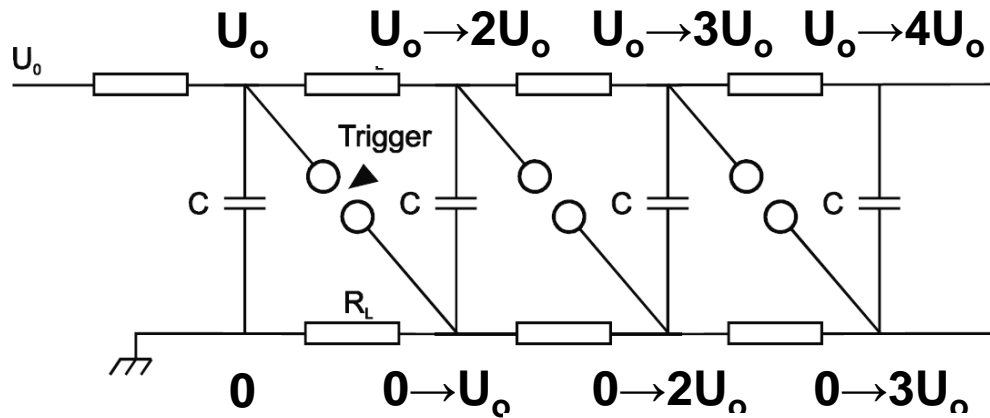

Other considerations



- To prevent prefire, each switch must be operated with a sufficient safety margin. $m \leq 2$ is needed, $m \ll 2$ for reliable switch.

$$m = \frac{V_0}{V_B}$$

- To prevent voltage reversal, a crowbar switch at the exit of the generator that fires just when the voltage starts to reverse.

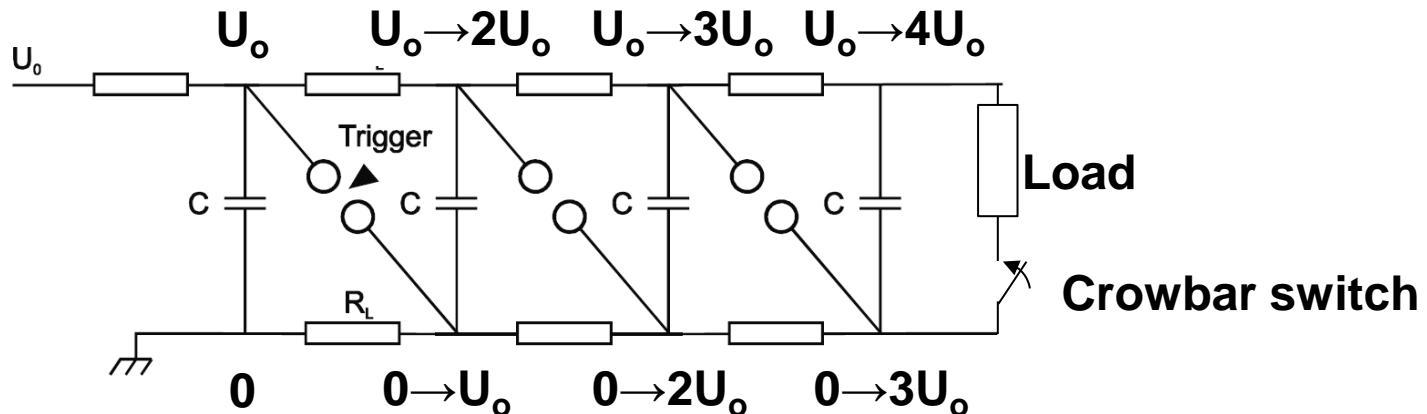

Discharge of a Marx generator including stray capacitors can be treated as a transmission line/pulse forming network

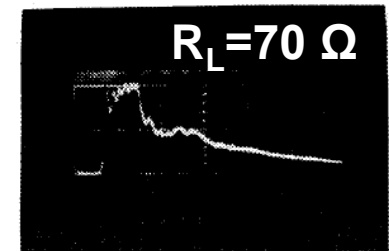
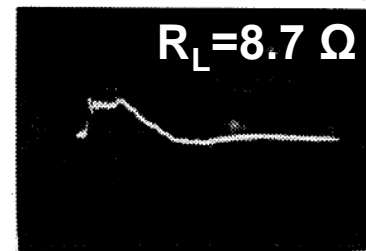
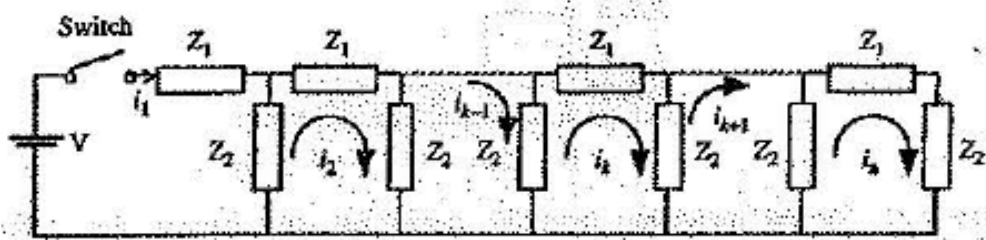
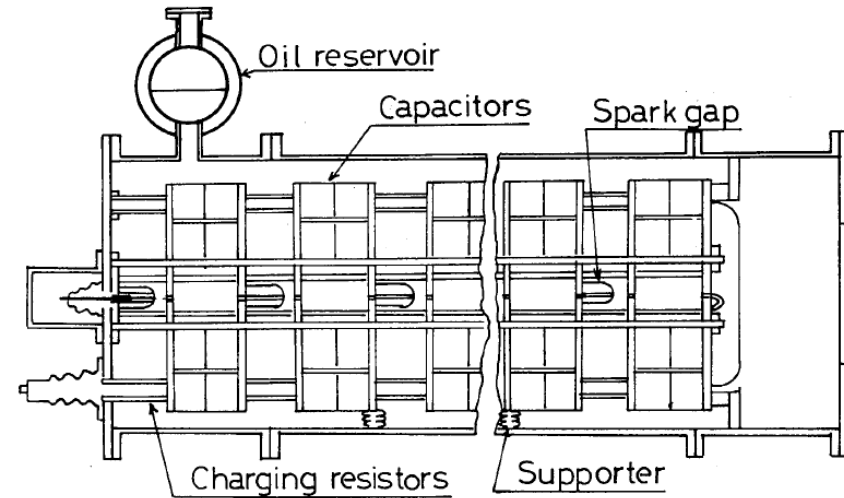
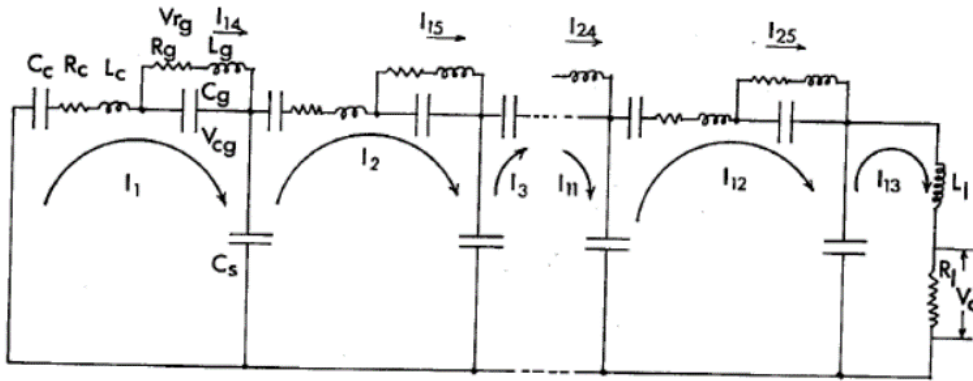

H : 50 ns/div
V : 160 kV/div

Switch can be taken away from the discharge path to reduce system inductance using “LC Marx Generator”

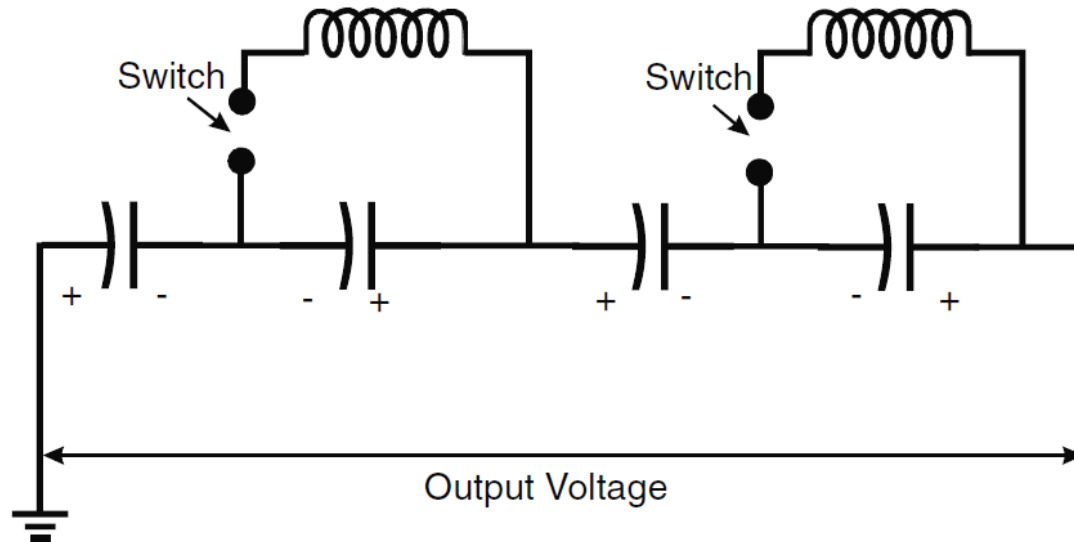
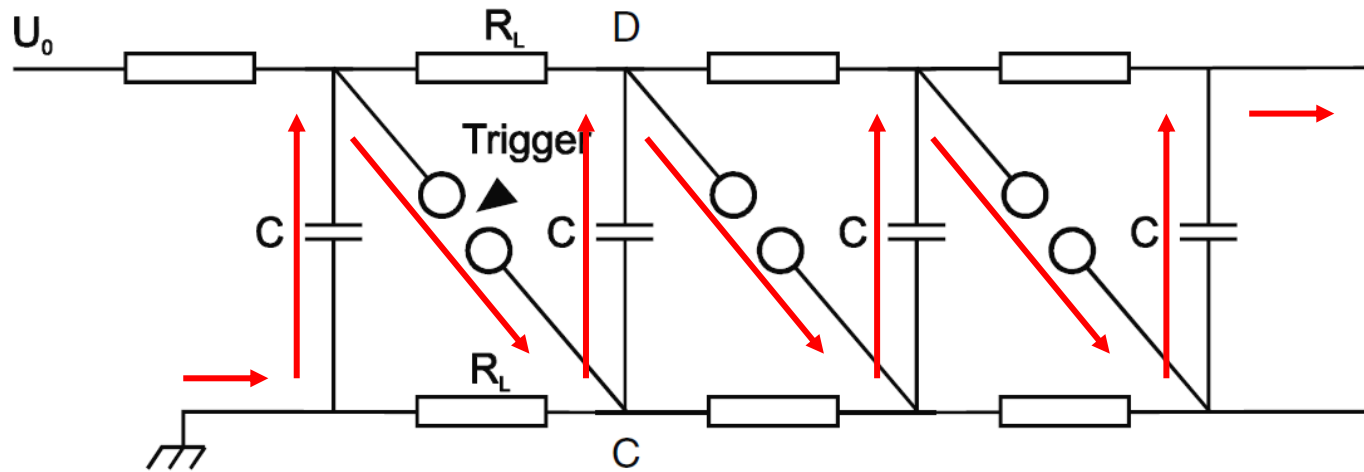

Switch can be taken away from the discharge path to reduce system inductance using “LC Marx Generator”

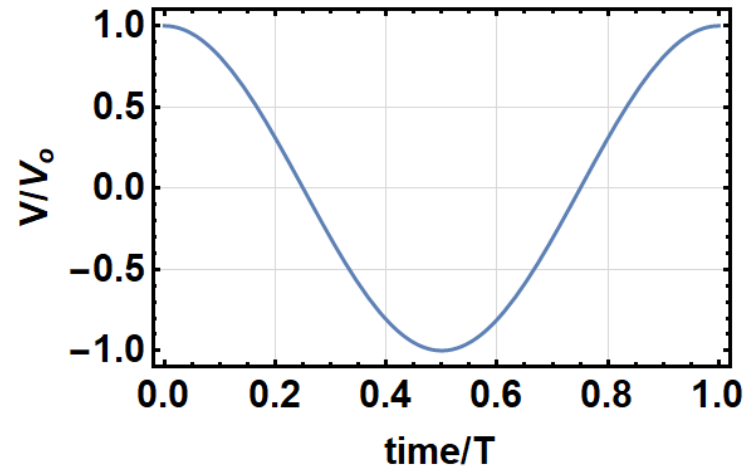
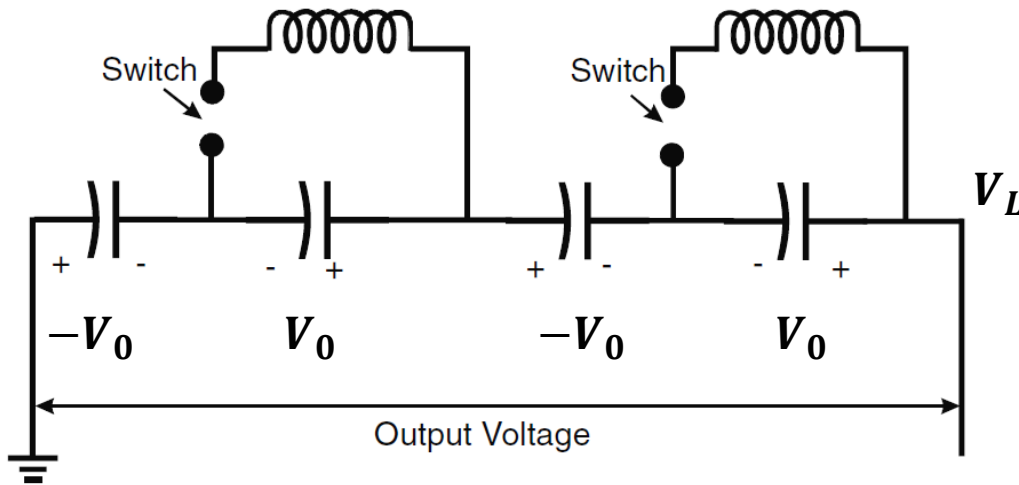

- $V_L = 0$ @ time = 0 .
- When switches are closed, LC oscillations happen.
- @ time=T/2, $V_L = -nV_0$. $V(t) = \frac{1}{2} nV_0 [1 - e^{-t/2\tau} \cos(\omega t)]$ $\omega = \frac{1}{\sqrt{LC}}$ $\tau = \frac{L}{R}$
 R: sum of resistance from switches, capacitors, and wires.
- Advantage: since switches locate outside the erected Marx circuit, inductance of the system is low!
- Disadvantage: all switches must be fired with very low jitter!

Load effects on the Marx discharge



- A resistor

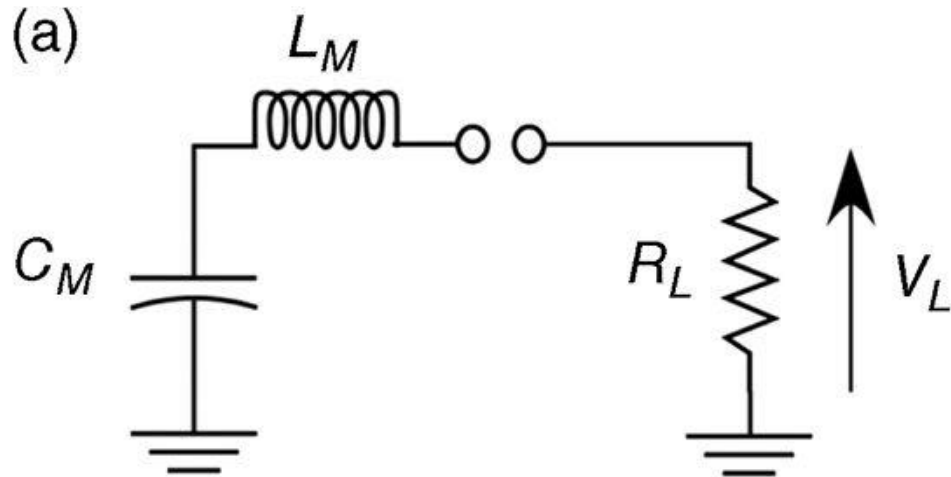

- A capacitor

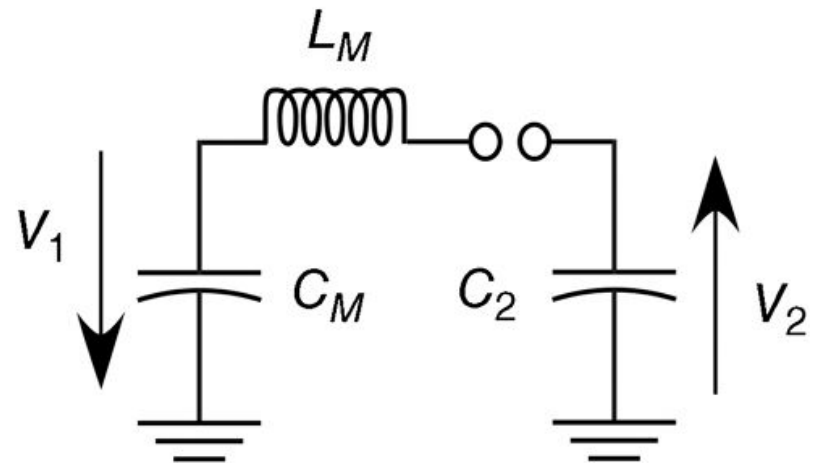

Resistive load



- The current and voltage are in phase and proportional, such as for relativistic e-beam generator or relativistic magnetron.

- Relativistic magnetron**

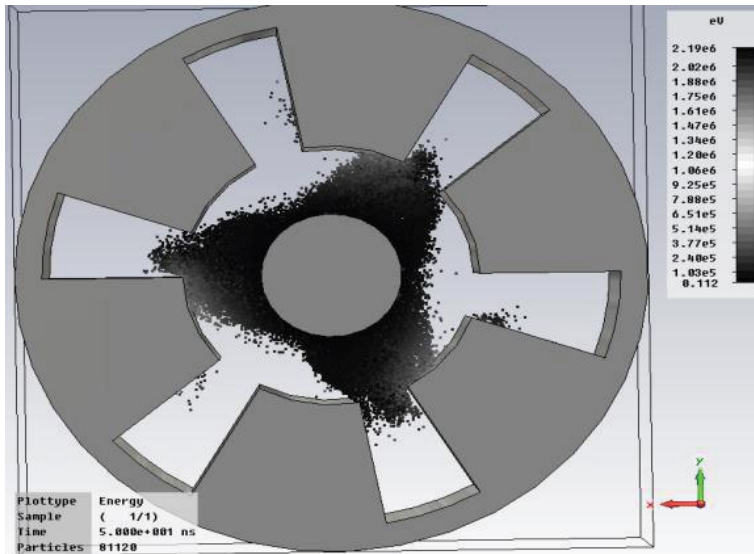

- Relativistic e-beam**

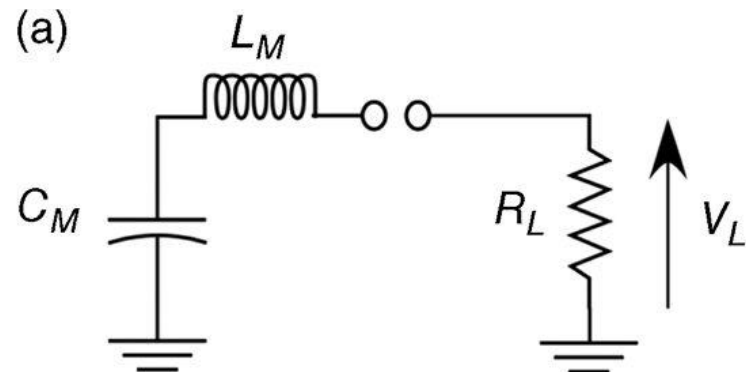
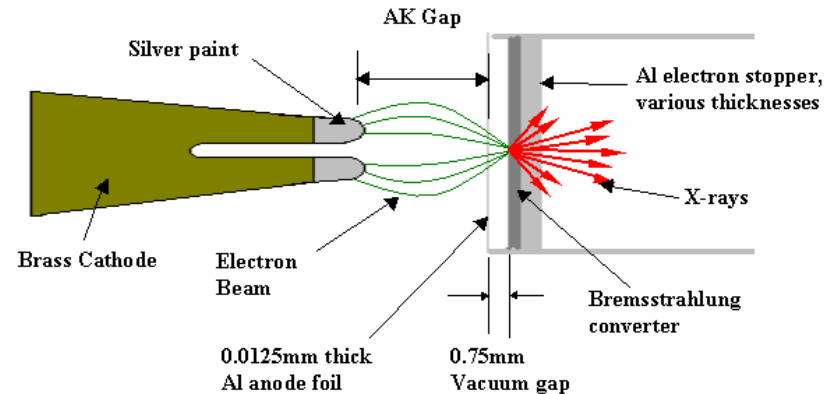

Resistive load



- The current and voltage are in phase and proportional, such as for relativistic e-beam generator or relativistic magnetron.
- If $L_M=0$: $V_L(t) = V_M e^{-t/(R_L C_M)}$
- In general cases, $L_M \neq 0$.

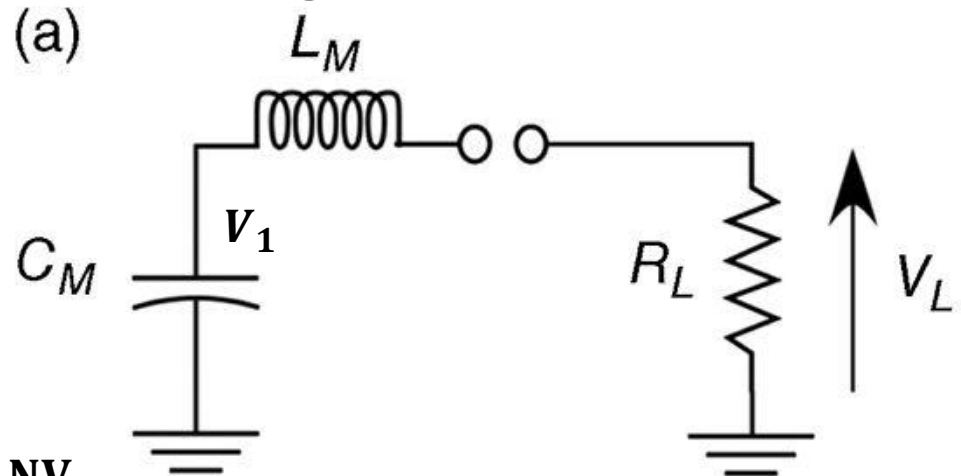

$$V_1 - L_M \frac{dI}{dt} - R_L I = 0$$

$$V_1 = V_M - \frac{1}{C_M} \int I dt \quad V_M = NV_0$$

$$\frac{dV_1}{dt} = \frac{I}{C_M} \quad \frac{I}{C_M} - L_M \frac{d^2 I}{dt^2} - R_L \frac{dI}{dt} = 0 \quad \frac{d^2 I}{dt^2} + \frac{R_L}{L_M} \frac{dI}{dt} + \frac{1}{L_M C_M} I = 0$$

$$D^2 + \frac{R_L}{L_M} D + \frac{1}{L_M C_M} = 0 \quad D = -\frac{R_L}{2L_M} \pm \sqrt{\left(\frac{R_L}{2L_M}\right)^2 - \frac{1}{L_M C_M}}$$

Resistive load



For $\frac{1}{L_M C_M} > \left(\frac{R_L}{2L_M}\right)^2$, $\omega \equiv \sqrt{\frac{1}{L_M C_M} - \left(\frac{R_L}{2L_M}\right)^2}$

$$I(t) = e^{-\frac{R_L}{2L_M}t} [\alpha \sin(\omega t) + \beta \cos(\omega t)]$$

$$I(0) = 0 \Rightarrow I(0) = \beta = 0$$

$$I(t) = \alpha e^{-\frac{R_L}{2L_M}t} \sin(\omega t)$$

$$\frac{dI}{dt} = \alpha \left[-\frac{R_L}{2L_M} \alpha e^{-\frac{R_L}{2L_M}t} \sin(\omega t) + \omega e^{-\frac{R_L}{2L_M}t} \cos(\omega t) \right]$$

$$L_M \frac{dI}{dt} \Big|_{t=0} = V_M \quad L_M \alpha \omega = V_M, \quad \alpha = \frac{V_M}{L_M \omega}$$

$$I = \frac{V_M}{L_M \omega} e^{-\frac{R_L}{2L_M}t} \sin(\omega t)$$

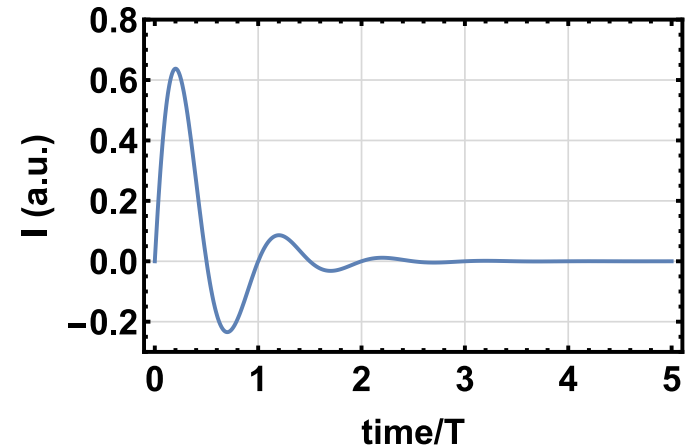
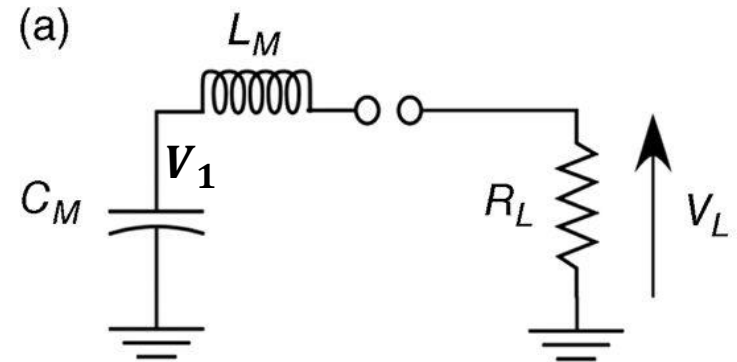

Resistive load



For $\frac{1}{L_M C_M} < \left(\frac{R_L}{2L_M}\right)^2$, $\gamma \equiv \sqrt{\left(\frac{R_L}{2L_M}\right)^2 - \frac{1}{L_M C_M}}$

$$I(t) = e^{-\frac{R_L}{2L_M}t} [\alpha e^{\gamma t} + \beta e^{-\gamma t}]$$

$$I(0) = 0 \Rightarrow \alpha + \beta = 0 \Rightarrow \beta = -\alpha$$

$$I(t) = \alpha e^{-\frac{R_L}{2L_M}t} [e^{\gamma t} - e^{-\gamma t}] = \alpha e^{(\gamma - \frac{R_L}{2L_M})t} - \alpha e^{-(\gamma + \frac{R_L}{2L_M})t}$$

$$\frac{dI}{dt} = \alpha \left[\left(\gamma - \frac{R_L}{2L_M} \right) e^{(\gamma - \frac{R_L}{2L_M})t} + \left(\gamma + \frac{R_L}{2L_M} \right) e^{-(\gamma + \frac{R_L}{2L_M})t} \right]$$

$$L_M \frac{dI}{dt} \Big|_{t=0} = \alpha \left[\left(\gamma - \frac{R_L}{2L_M} \right) + \left(\gamma + \frac{R_L}{2L_M} \right) \right] = V_M \quad 2L_M \alpha \gamma = V_M, \quad \alpha = \frac{V_M}{2L_M \gamma}$$

$$I = \frac{V_M}{2L_M \gamma} e^{-\frac{R_L}{2L_M}t} [e^{\gamma t} - e^{-\gamma t}] \approx \frac{V_M}{2L_M \gamma} e^{-\frac{R_L}{2L_M}t} e^{\gamma t}$$

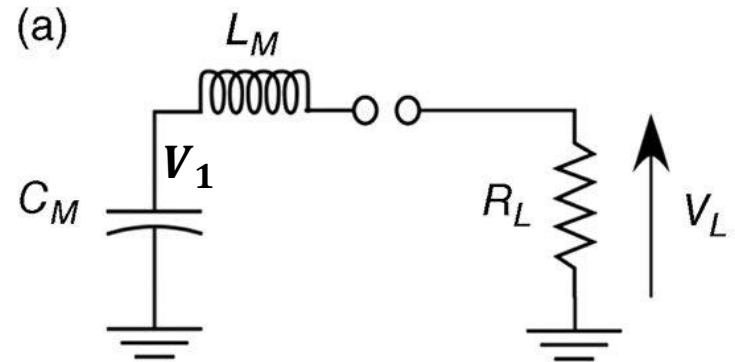

Resistive load



$$I = \frac{V_M}{2L_M\gamma} e^{-\frac{R_L}{2L_M}t} [e^{\gamma t} - e^{-\gamma t}] \approx \frac{V_M}{2L_M\gamma} e^{-\frac{R_L}{2L_M}t} e^{\gamma t}$$

$$\frac{dI}{dt} = \alpha \left[\left(\gamma - \frac{R_L}{2L_M} \right) e^{\left(\gamma - \frac{R_L}{2L_M} \right) t} + \left(\gamma + \frac{R_L}{2L_M} \right) e^{-\left(\gamma + \frac{R_L}{2L_M} \right) t} \right] \equiv 0$$

$$\left(\gamma - \frac{R_L}{2L_M} \right) e^{\gamma t} + \left(\gamma + \frac{R_L}{2L_M} \right) e^{-\gamma t} = 0 \quad \gamma \equiv \sqrt{\left(\frac{R_L}{2L_M} \right)^2 - \frac{1}{L_M C_M}}$$

$$\left(\gamma - \frac{R_L}{2L_M} \right) e^{2\gamma t} + \left(\gamma + \frac{R_L}{2L_M} \right) = 0$$

$$e^{2\gamma t} = \frac{\frac{R_L}{2L_M} + \gamma}{\frac{R_L}{2L_M} - \gamma} \quad t_{\text{Imax}} = \frac{1}{2\gamma} \ln \left(\frac{\frac{R_L}{2L_M} + \gamma}{\frac{R_L}{2L_M} - \gamma} \right)$$

$$L_M \uparrow \quad \rightarrow \quad \gamma \downarrow \quad e^{\gamma t} \downarrow \quad -\frac{R_L}{2L_M} \uparrow \quad e^{-\frac{R_L}{2L_M}t} \uparrow$$

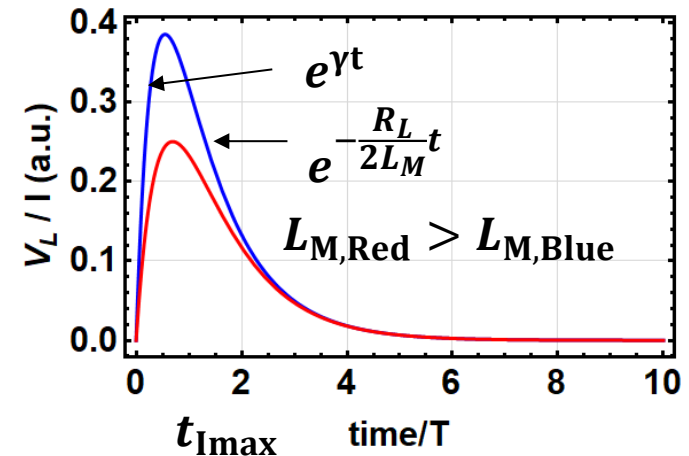
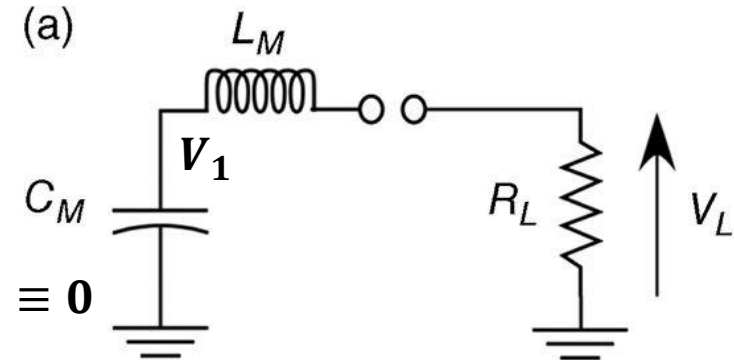

Capacitor load



- Pulse compression scheme: a charged capacitor can transfer almost all of its energy to an uncharged capacitor if connected through an inductor.
- Output voltage can be doubled in a peaking circuit.

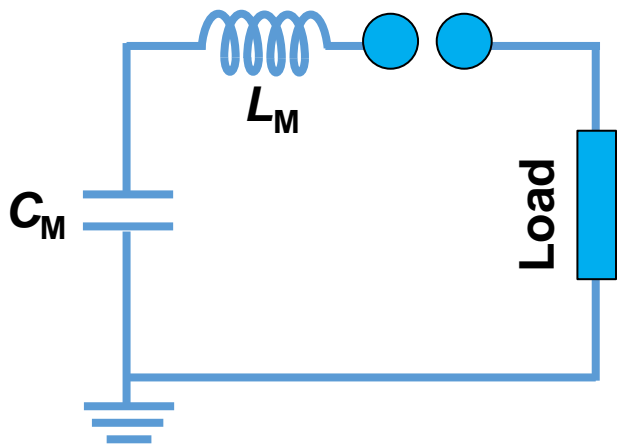

$$I_0 = \frac{V_0}{\sqrt{L_M/C_M}} \quad \omega_0 = \frac{1}{\sqrt{L_M C_M}}$$

$$L_M > L_2$$

=>

$$I_M < I_2$$

$$\omega_M < \omega_2$$

$$T_M > T_2$$

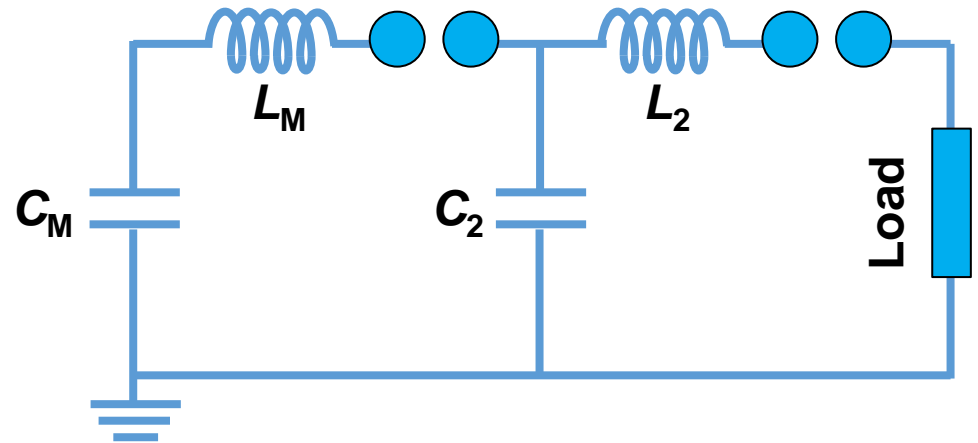

$$I_2 = \frac{V_0}{\sqrt{L_2/C_2}} \quad \omega_2 = \frac{1}{\sqrt{L_2 C_2}}$$

Intermediate storage capacitors can be used to compress the pulse

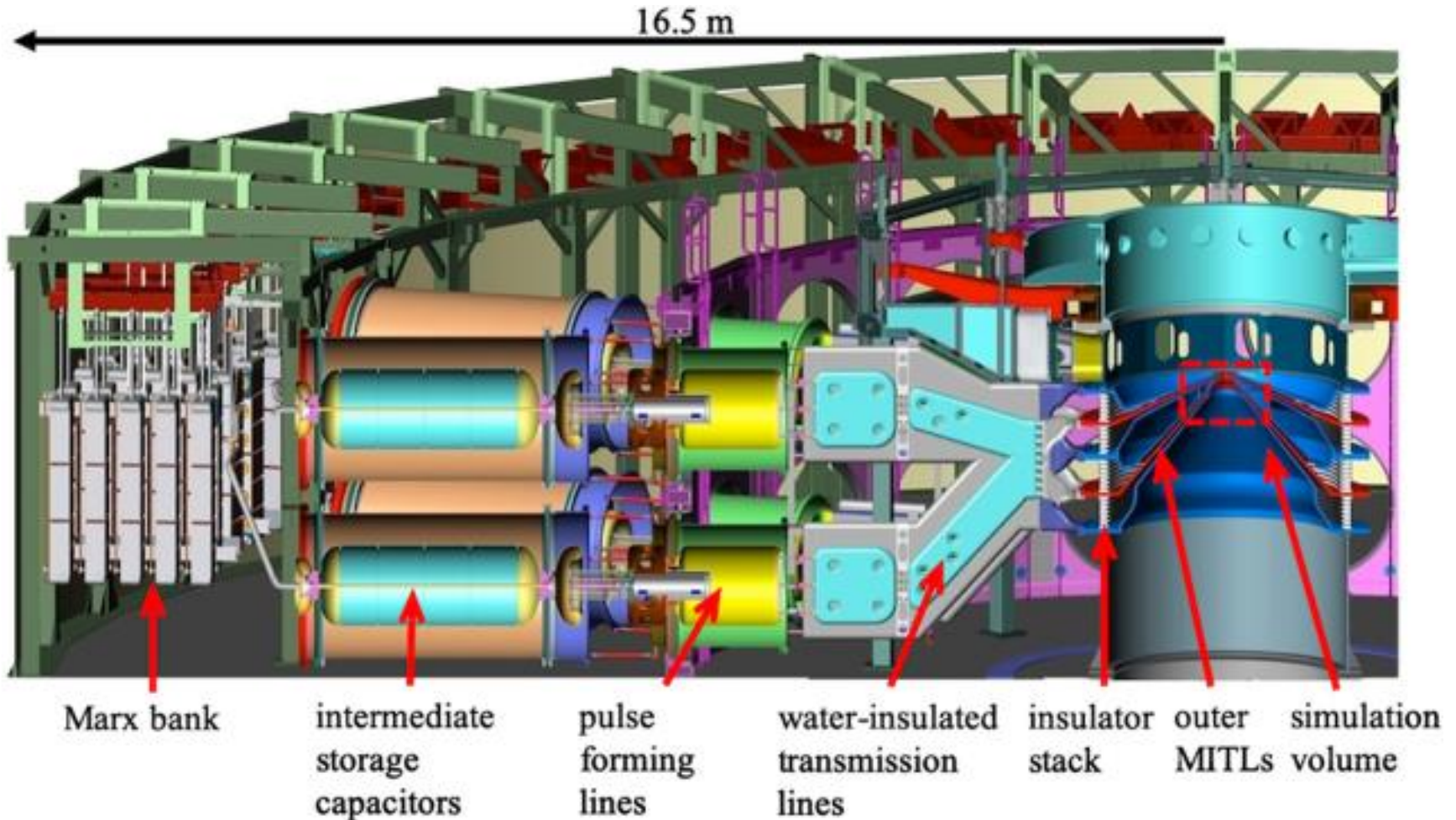

Capacitor load



$$V_1 - L_M \frac{dI}{dt} = V_2$$

$$V_1 = V_M - \frac{1}{C_M} \int I dt \quad V_M = NV_0$$

$$V_2 = \frac{1}{C_2} \int I dt$$

$$V_M - \frac{1}{C_M} \int I dt - L_M \frac{dI}{dt} = \frac{1}{C_2} \int I dt$$

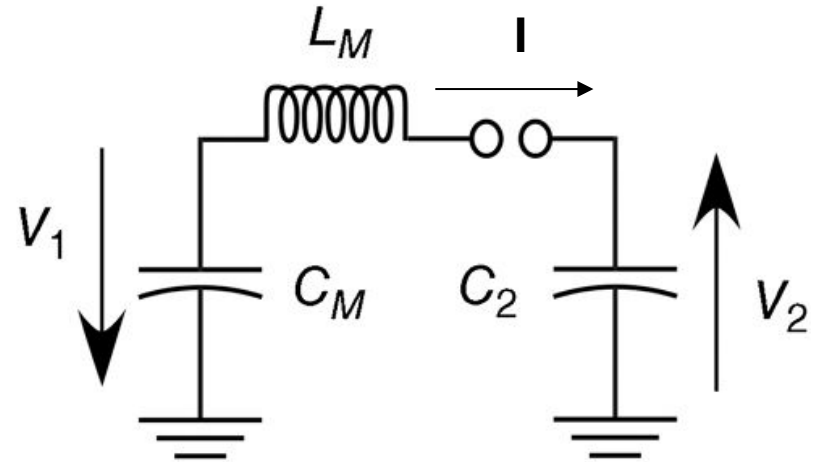

$$-\frac{1}{C_M} I - L_M \frac{d^2 I}{dt^2} = \frac{1}{C_2} I \quad L_M \frac{d^2 I}{dt^2} + \left(\frac{1}{C_M} + \frac{1}{C_2} \right) I = 0$$

$$\frac{d^2 I}{dt^2} + \frac{1}{L_M C_{\text{eff}}} I = 0 \quad \frac{1}{C_{\text{eff}}} = \frac{1}{C_M} + \frac{1}{C_2} \quad \omega = \sqrt{\frac{1}{L_M C_{\text{eff}}}}$$

$$I = \alpha \sin(\omega t) + \beta \cos(\omega t)$$

Capacitor load



$$I = \alpha \sin(\omega t) + \beta \cos(\omega t)$$

$$I(t = 0) = 0 \Rightarrow \beta = 0$$

$$I = \alpha \sin(\omega t)$$

$$\frac{dI}{dt} = \alpha \omega \cos(\omega t)$$

$$L_M \left. \frac{dI}{dt} \right|_{t=0} = L_M \alpha \omega = V_M \quad \alpha = \frac{V_M}{L_M \omega}$$

$$I(t) = \frac{V_M}{L\omega} \sin(\omega t)$$

$$V_1 = V_M - \frac{1}{C_M} \int_0^t \frac{V_M}{L\omega} \sin(\omega t) dt = V_M - \frac{V_M C_2}{C_M + C_2} [1 - \cos(\omega t)]$$

$$V_2 = \frac{1}{C_2} \int_0^t \frac{V_M}{L\omega} \sin(\omega t) dt = \frac{V_M C_M}{C_M + C_2} [1 - \cos(\omega t)] \quad \left. \frac{V_2}{V_M} \right|_{\max} = \frac{2C_M}{C_M + C_2}$$

$$\text{for } C_2 \sim C_M, \frac{V_2}{V_M} \sim 1$$

$$\text{for } C_2 \ll C_M, \frac{V_2}{V_M} \sim 2$$

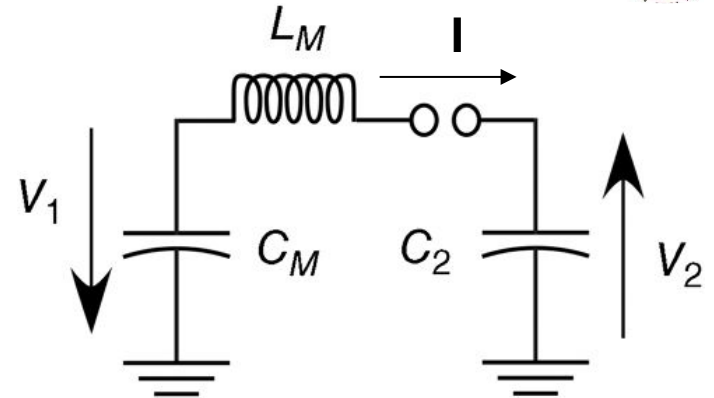

Peaking circuit, $C_2 \ll C_M$



$$V_1 = V_M - \frac{V_M C_2}{C_M + C_2} [1 - \cos(\omega t)] \approx V_M - \frac{V_M C_2}{C_M} [1 - \cos(\omega t)]$$

$$V_2 = \frac{V_M C_M}{C_M + C_2} \frac{V_M C_2}{C_M} [1 - \cos(\omega t)] \approx V_M [1 - \cos(\omega t)]$$

For $t = \frac{\pi}{\omega}$, $\cos(\omega t) = \cos(\pi) = -1$

$$V_1 \approx V_M$$

$$V_2 \approx 2V_M$$

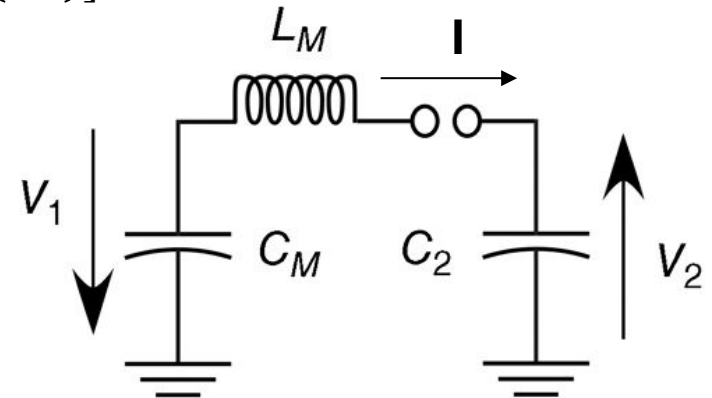
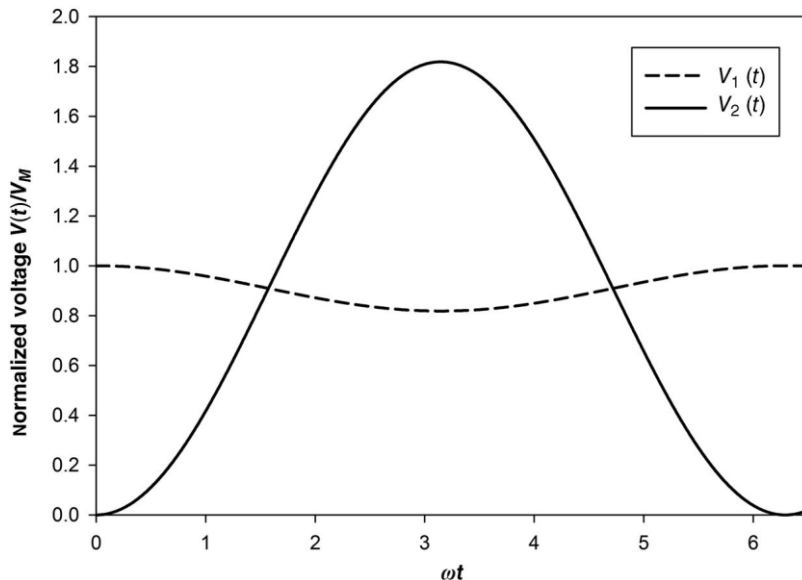

- The energy transfer is inefficient.
- $C_M/C_2 \sim 10$ is normally used.

Pulse compression scheme: $C_2 \sim C_M$

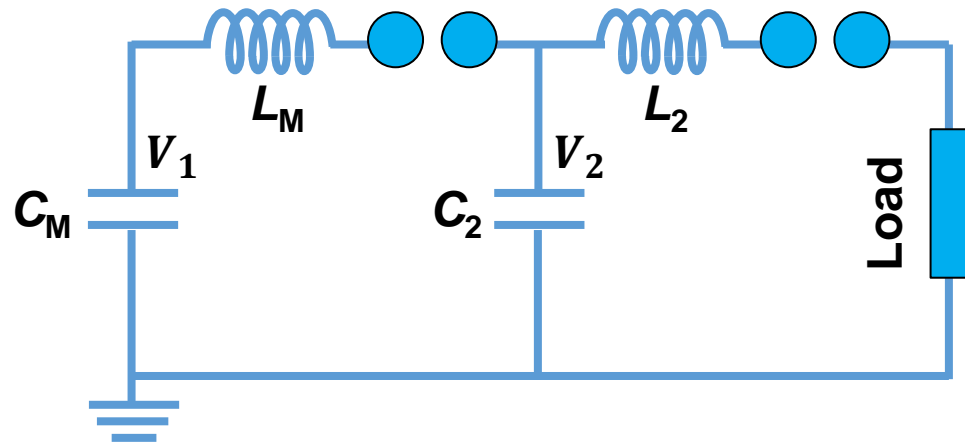
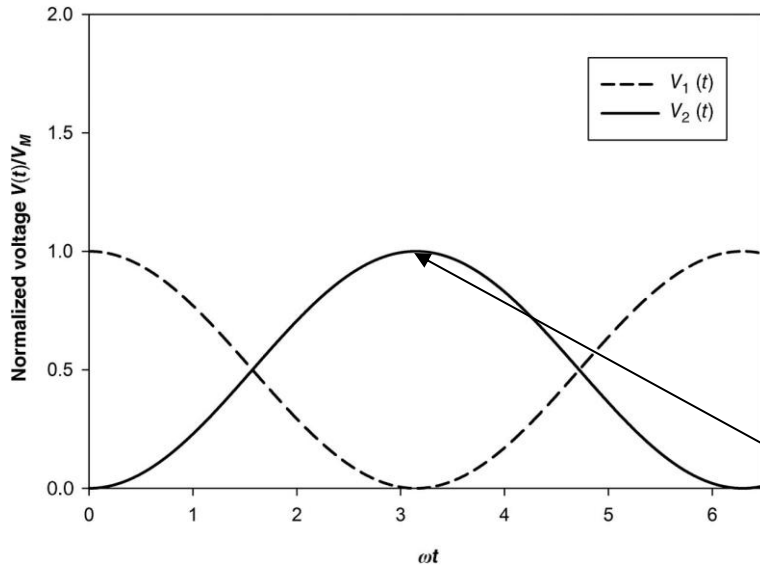

Energy is fully transferred to the 2nd cap, i.e., intermediate storage capacitor.

$$V_1 = V_M - \frac{V_M C_2}{C_M + C_2} [1 - \cos(\omega t)] \approx V_M - \frac{V_M}{2} [1 - \cos(\omega t)]$$

$$V_2 = \frac{V_M C_M}{C_M + C_2} \frac{V_M}{2} [1 - \cos(\omega t)] \approx \frac{V_M}{2} \frac{V_M C_M}{C_M + C_2} \frac{V_M}{2} [1 - \cos(\omega t)]$$

For $t = \frac{\pi}{\omega}$, $V_1 \approx 0$, $V_2 \approx V_M$

Water is commonly used as the dielectric material for the intermediate capacitor



$$C = \frac{2\pi\epsilon_r\epsilon_0}{\ln(b/a)} l \quad \text{For } \frac{b}{a} = \frac{1}{0.9} \approx 1.1$$

$$\text{Air: } \epsilon_r = 1 \Rightarrow \frac{C}{L} = 0.5 \times 10^{-9} \text{ F/m}$$

$$\text{Water: } \epsilon_r = 80 \Rightarrow \frac{C}{L} = 6.25 \times 10^{-12} \text{ F/m}$$

$$\text{For KALIF: } C_M = \frac{0.5\mu\text{F}}{25} = 25\text{nF}$$

$$\text{Using air: } l = \frac{25 \times 10^{-9}}{0.5 \times 10^{-9}} = 40 \text{ m}$$

$$\text{Using water: } l = \frac{25 \times 10^{-9}}{6.25 \times 10^{-12}} = 0.5 \text{ m}$$

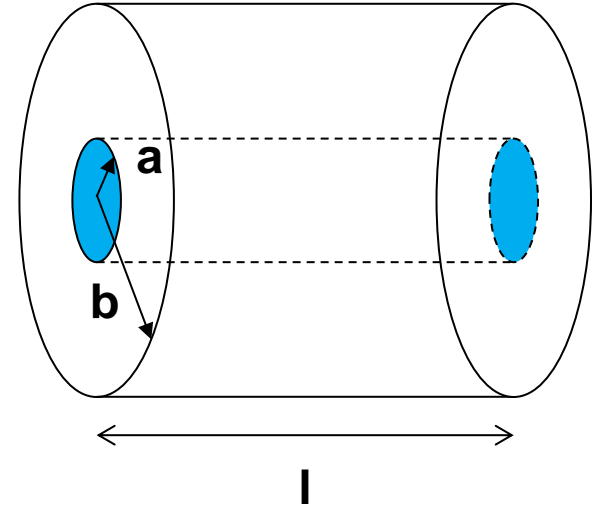

Intermediate storage capacitors can be used to compress the pulse

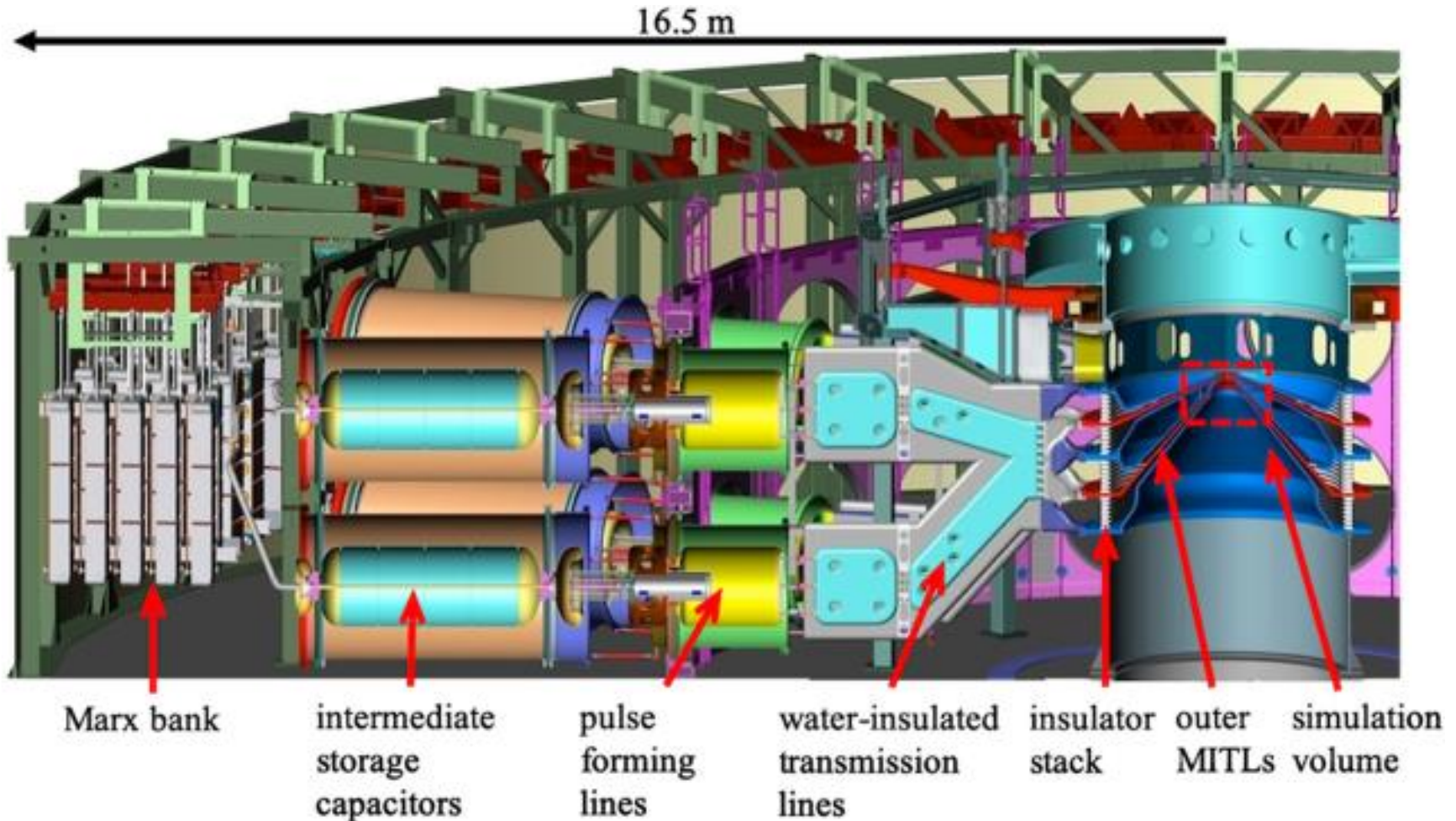

Outlines



- Introduction to pulsed-power system
- Review of circuit analysis
- Static and dynamic breakdown strength of dielectric materials
 - Gas – Townsend discharge (avalanche breakdown), Paschen's curve
 - Liquid
 - Solid
- **Energy storage**
 - Pulse discharge capacitors
 - Marx generators
 - **Inductive energy storage**

Inductive energy storage



- Capacitive energy storage – current amplifier.
- Inductive energy storage – voltage amplifier.
- Notice that energy density of the inductive energy storage is 2 order higher than that of the capacitive energy storage.
- If I_o is large, charging of the inductor must be fast. It is because the energy loss in the resistance of the inductor windy and the opening switch.
- Current source has high internal impedance ($R_g \gg R$) and a large power ($t_{\text{charge}} \downarrow$).

$$I_{\text{max}} = I_o \frac{R_g}{R_g + R}$$

$$I(t) = I_o \frac{R_g}{R_g + R} \left(1 - e^{-\frac{R+R_g}{L}t} \right)$$

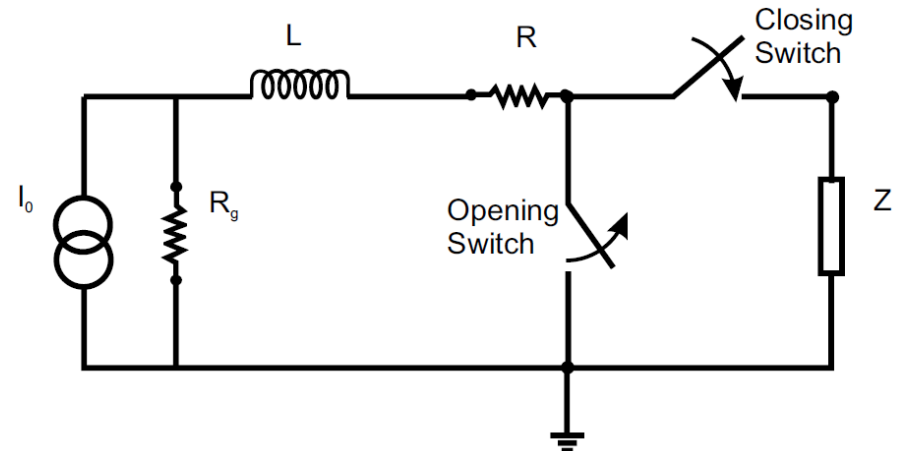

Output of the inductive storage



- Assumption: at $t=0$, inductance is fully charged. Resistance of the inductive storage is neglected.

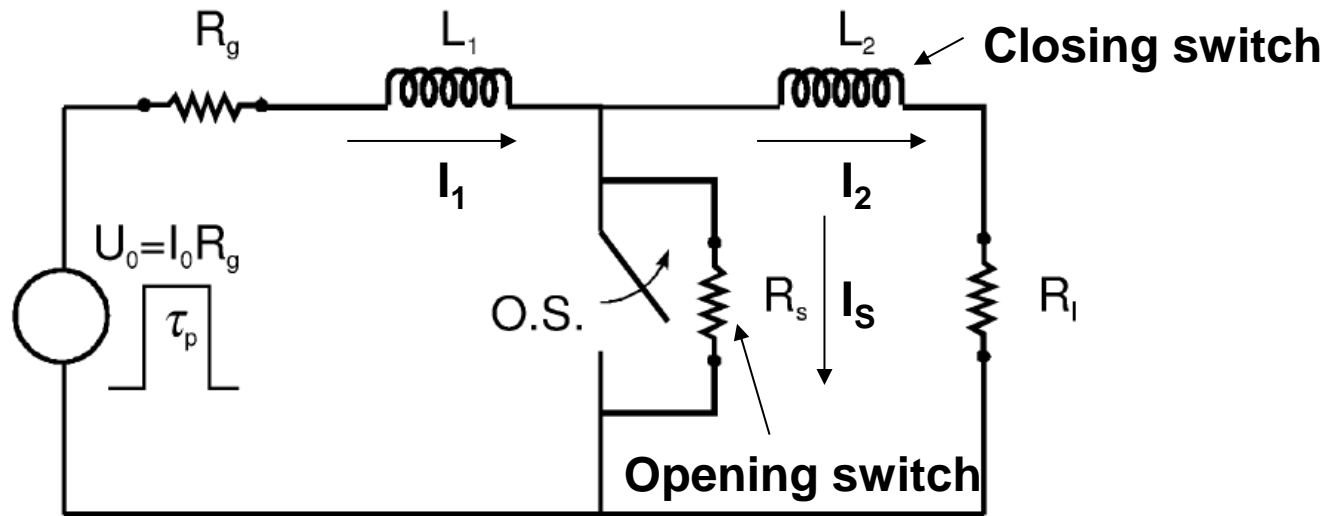

$$R_g I_1 + L_1 \frac{dI_1}{dt} + R_S(I_1 - I_2) = 0 \quad \tau_{\pm} = \left(\frac{R_l + R_S}{2L_S} + \frac{R_g + R_S}{2L_1} \right)$$

$$R_l I_2 + L_2 \frac{dI_2}{dt} + R_S(I_2 - I_1) = 0 \quad \times \left[1 \pm \sqrt{1 - \frac{4L_1 L_2 [(R_l + R_S)(R_g + R_S) - R_S^2]}{[L_1(R_l + R_S) + L_2(R_g + R_S)]^2}} \right]$$

Spark plugs in cars are triggered by the inductive energy storage



Closing switch /load

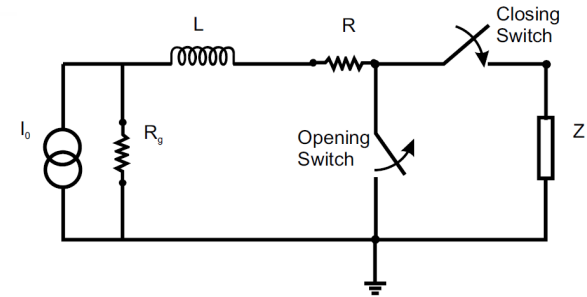
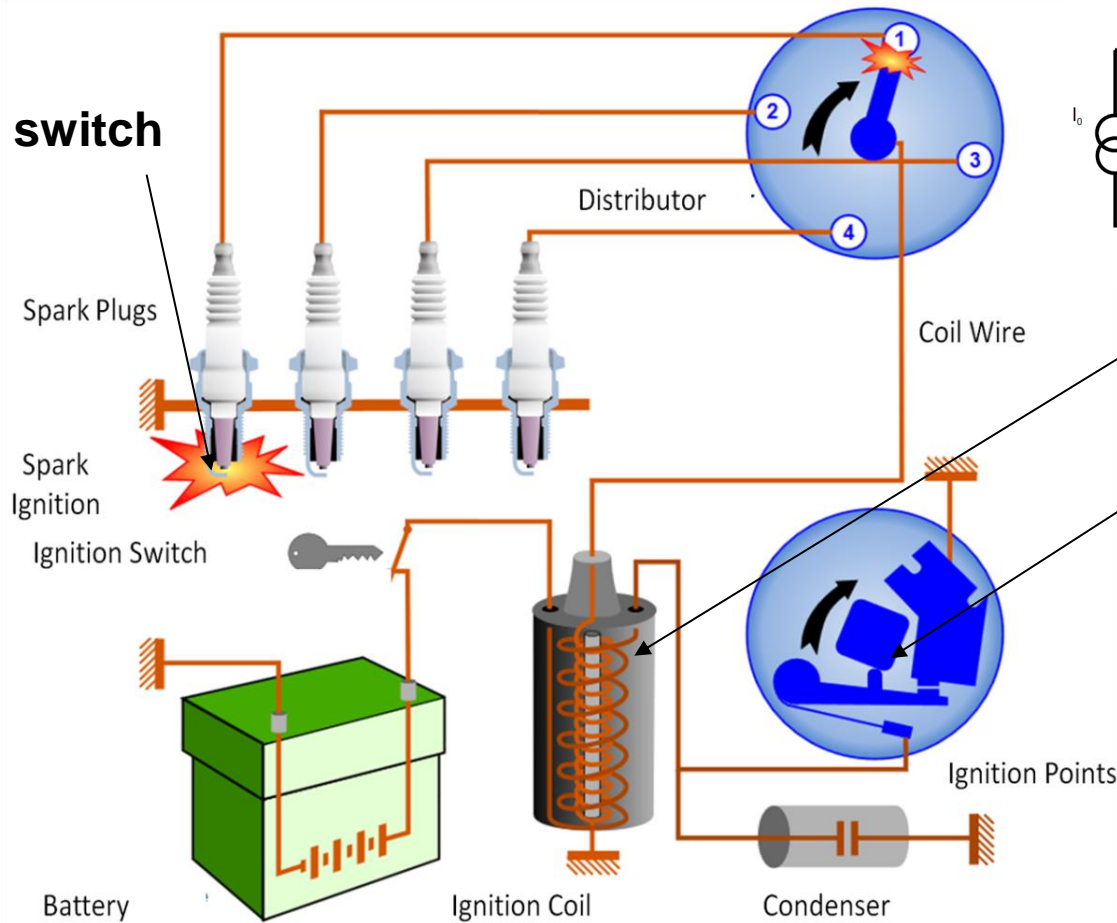

Inductive energy storage

Opening switch

Triggering pulse for PGS machine

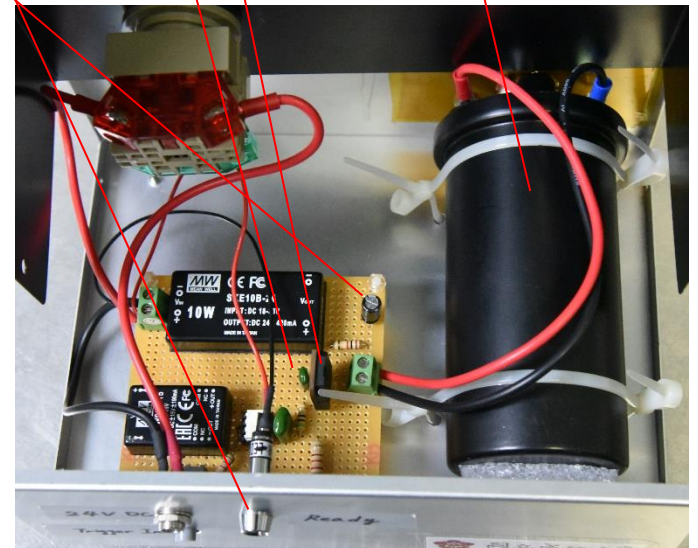
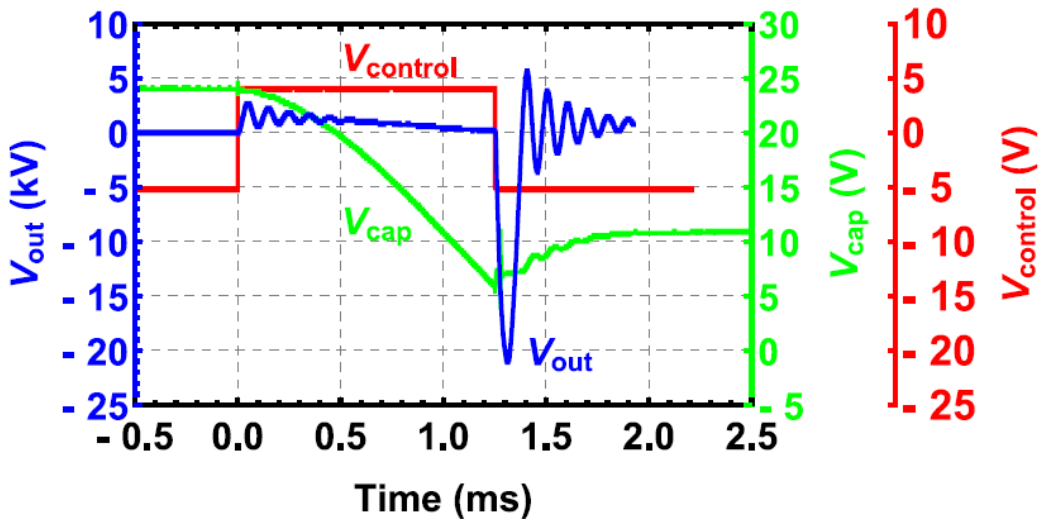
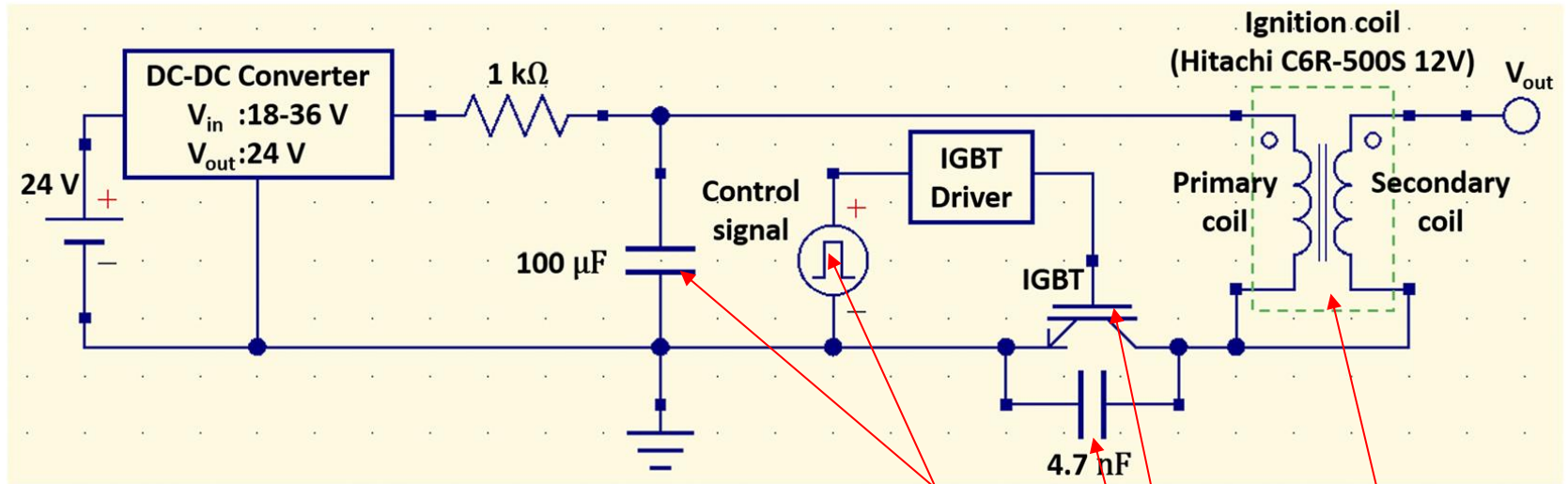

Pulsed-plasma thruster

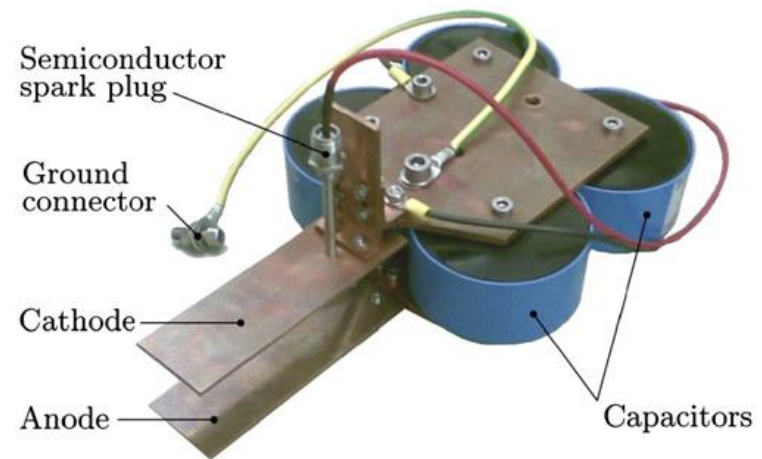
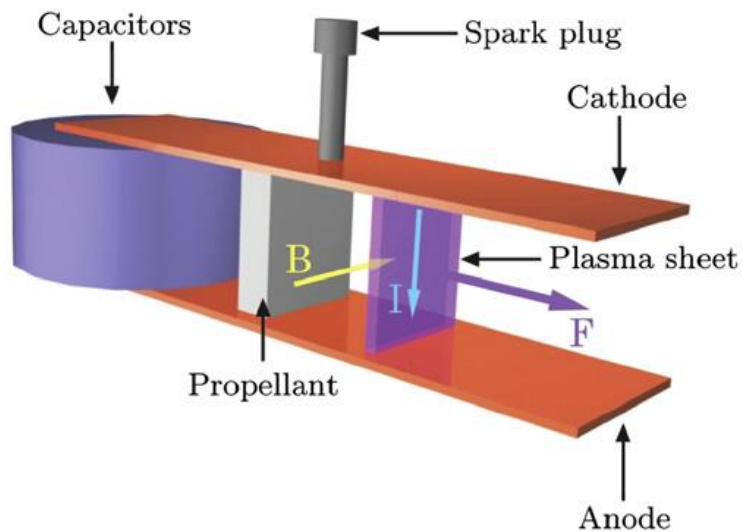
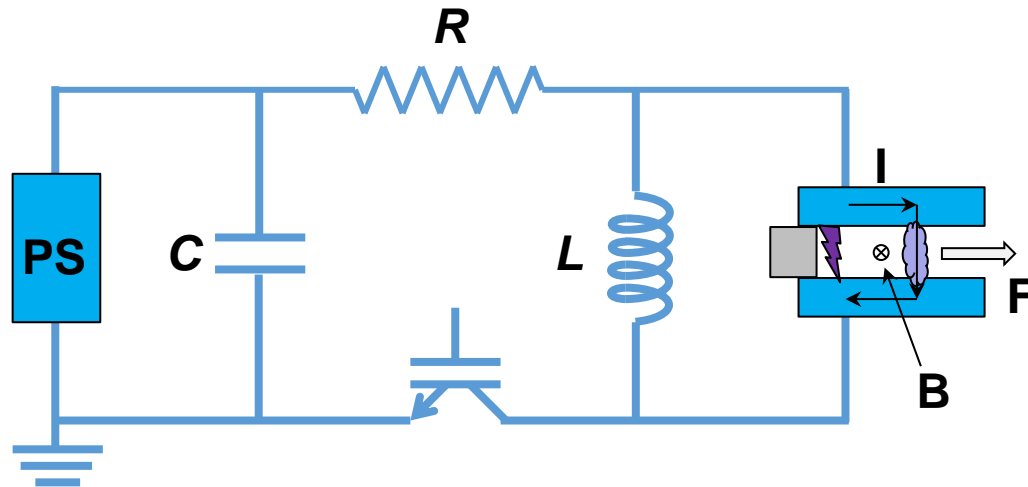

Loop voltage for breakdown is provided by dropping the current of the central solenoid rapidly

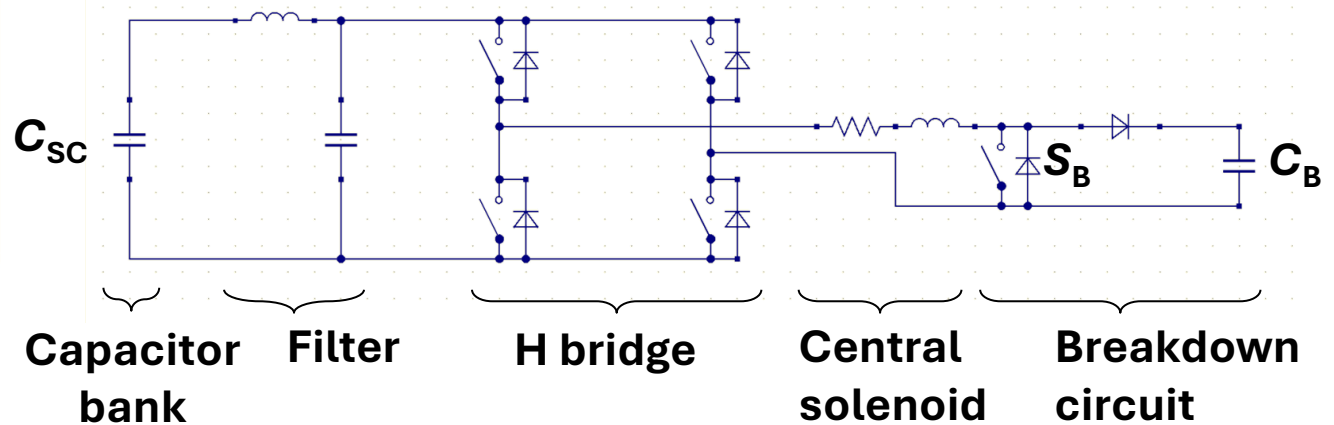
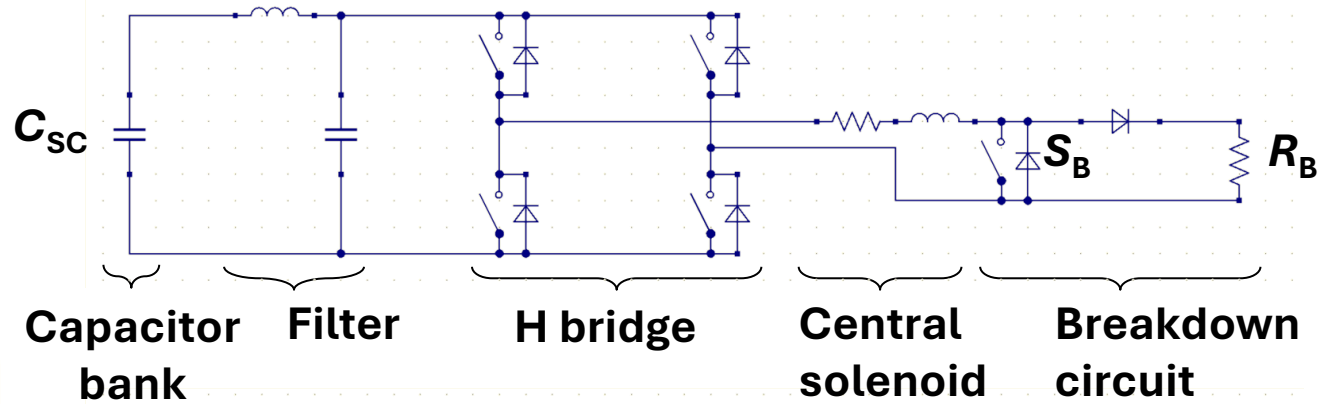
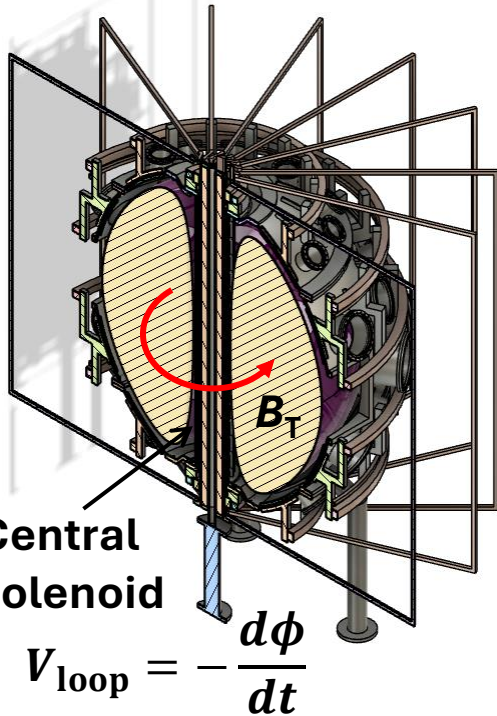
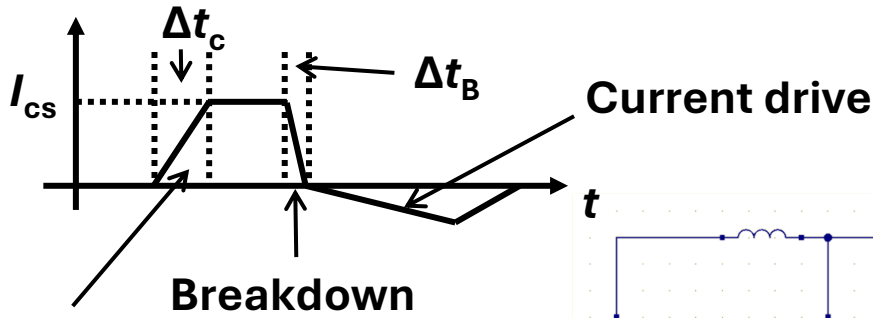

Outlines



- Introduction to pulsed-power system
- Review of circuit analysis
- Static and dynamic breakdown strength of dielectric materials
 - Gas – Townsend discharge (avalanche breakdown), Paschen's curve
 - Liquid
 - Solid
- **Energy storage**
 - Pulse discharge capacitors
 - Marx generators
 - Inductive energy storage
 - **Rotors and Homopolar generators**

Rotors and Homopolar generators



- Pulsed current source is needed such that charge time $\ll L/R$
 \Rightarrow using flywheel. $W_{\text{kin}} = \frac{1}{2} \theta \omega^2$
- Energy density $\sim 300 \text{ MJ/m}^3$, total energy $> 100 \text{ MJ}$.
- Can transfer its energy only in a time $> 10 \text{ ms}$ in most cases.
- Homopolar generator:
- In a self-exciting generator, B is created by the output current of the rotor.

$$V = \alpha I \omega$$

$$L \frac{dI}{dt} + IR = \alpha I \omega$$

$$\frac{1}{2} \theta \omega^2 + \frac{1}{2} LI^2 + \int_0^t I^2 R dt = \frac{1}{2} \theta \omega_0^2$$

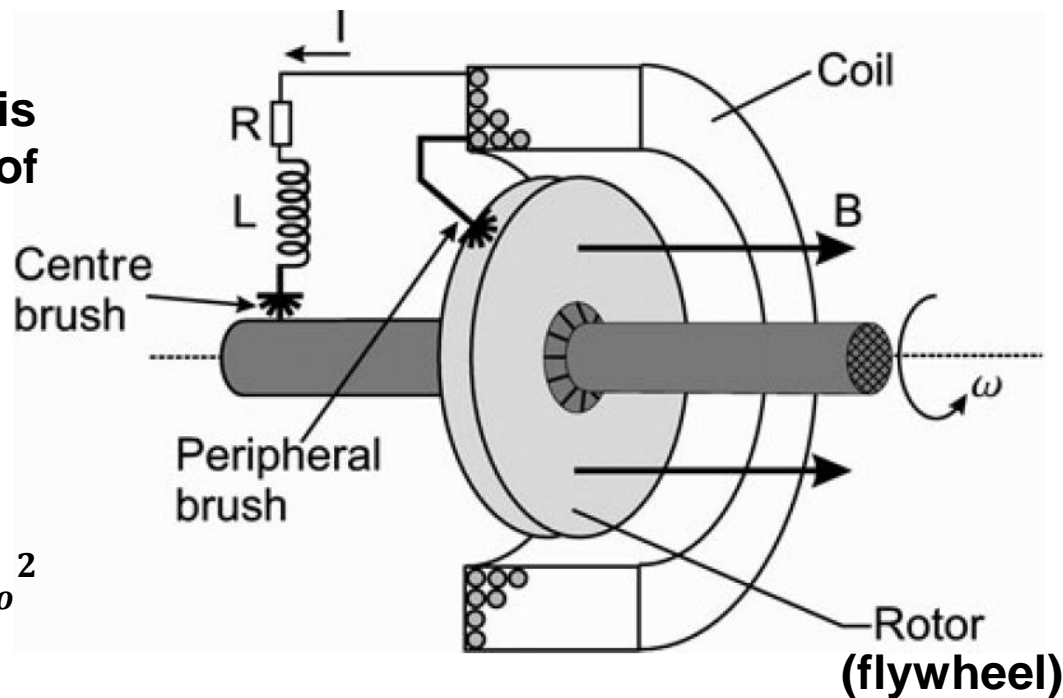

Rotor (flywheel)

Homopolar generators

