

PULSED POWER SYSTEM

脈衝功率系統



Po-Yu Chang

Institute of Space and Plasma Sciences, National Cheng Kung University

2023 Fall Semester

Tuesday 9:10-12:00

Lecture 10

<http://capst.ncku.edu.tw/PGS/index.php/teaching/>

Online courses:

<https://nckucc.webex.com/nckucc/j.php?MTID=md577c3633c5970f80cbc9e821927e016>

Multistage spark-gap switch with laser triggering



- Simply scaling a three-electrode spark gap to multimegavolt operating voltages would lead to large gaps, making the jitter and inductance unacceptably high.
- Operating voltage of up to 6 MV and a switch current of 0.5 MA.
- It consists of 15 equal spark gaps and a trigger section.
- The operating voltage is around 90% of the self-breakdown value with a prefire probability of 0.1 %.
- The gap capacitances are small, 20 % of the operating voltage occurs across the trigger section.

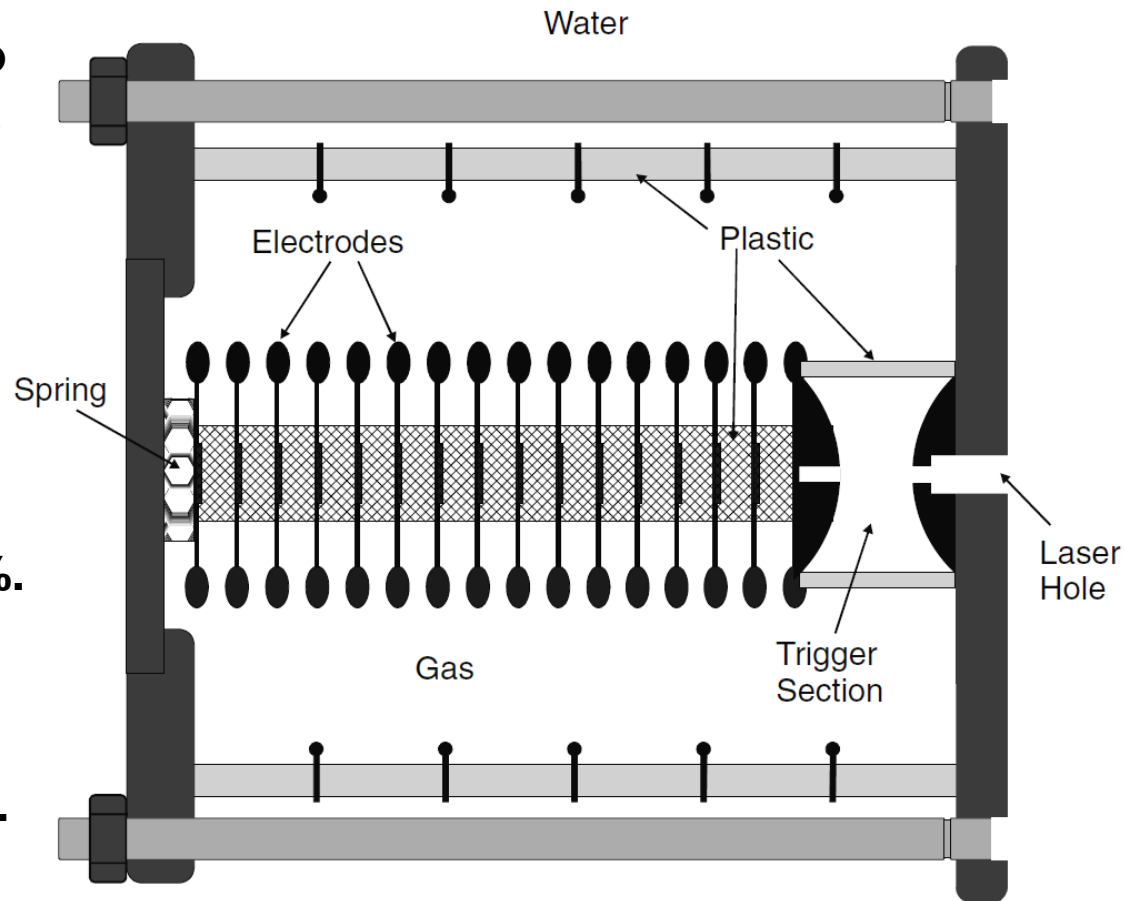

Multistage spark-gap switch with laser triggering



- The switch is 68 cm long and 61 m in diameter.
- The 1st gap is 5.7 cm and a UV laser pulse (KrF) with a 25 mJ pulse energy is necessary.
- ~1 ns after the laser pulse, a breakdown occurs in the trigger gap and the voltage increases across the remaining gaps rapidly. An ignition wave propagates to the other gaps and ignites them sequentially.
- Total inductance: 400 nH; Trigger delay: 20 ns; jitter <0.4 ns.

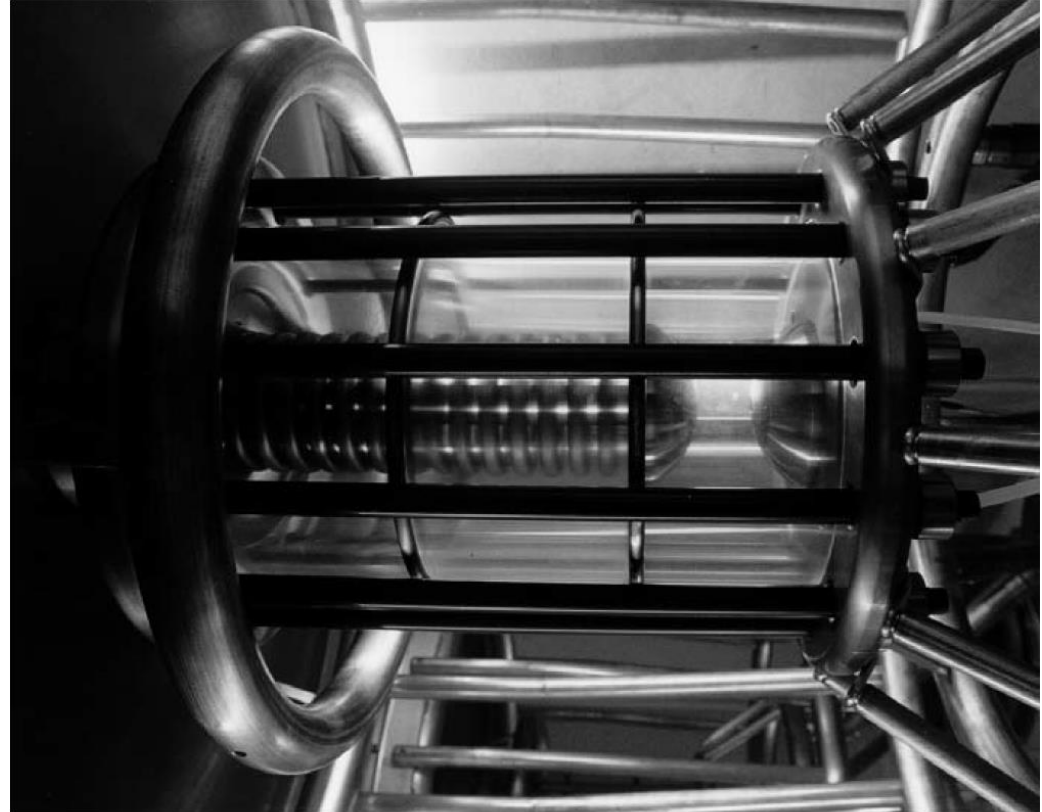
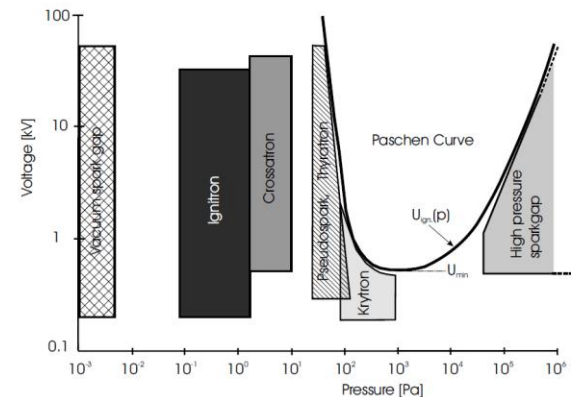
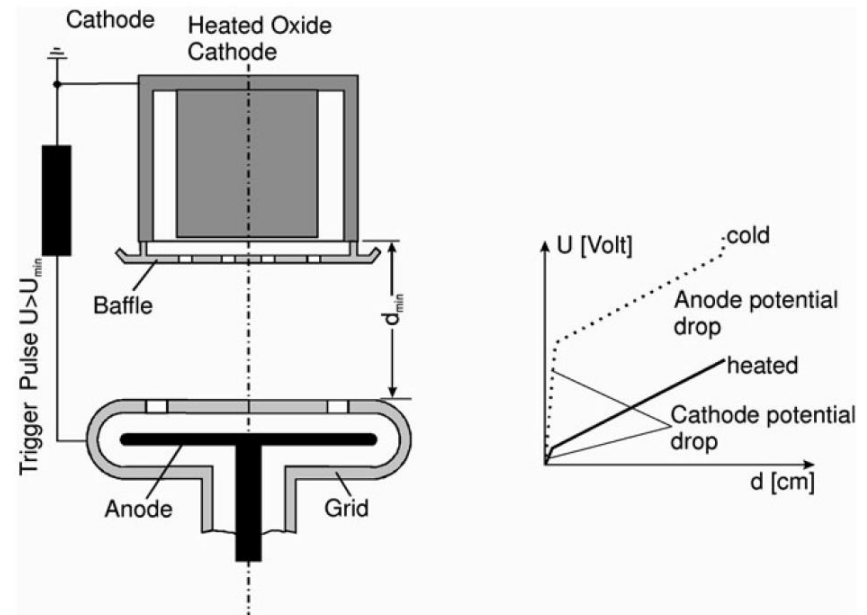

Fig. 4.13. A 4 MV version of a multigap spark switch

Thyratrons



- Thyratrons are gas-filled switching devices with a gas pressure (30-80 Pa/ $3 \times 10^{-4} - 8 \times 10^{-4}$ atm) much lower than a spark-gap switches.
- A triode configuration is used.
- The thyratron is characterized by the presence of a plasma, which allows the passage of large currents without significant electrode erosion.
- The hold-off voltage is limited by field emission, $> 10^5$ V/cm.
- The anode-grid distance is 2-3 mm, ~ 40 kV hold-off voltage.



Thyratrons



- The cathode-grid distance corresponds to the Paschen minimum U_{\min} .
- If $U > U_{\min}$, a glow discharge is initiated between the cathode and the grid. \Rightarrow electrons from the glow discharge plasma can migrate rapidly through the openings in the grid to the main discharge region between the grid and the anode. \Rightarrow thyratron closes.

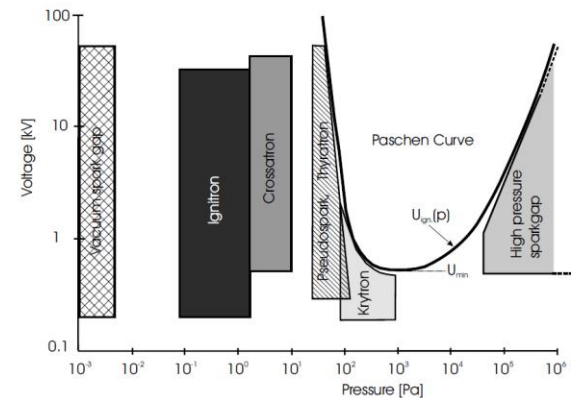
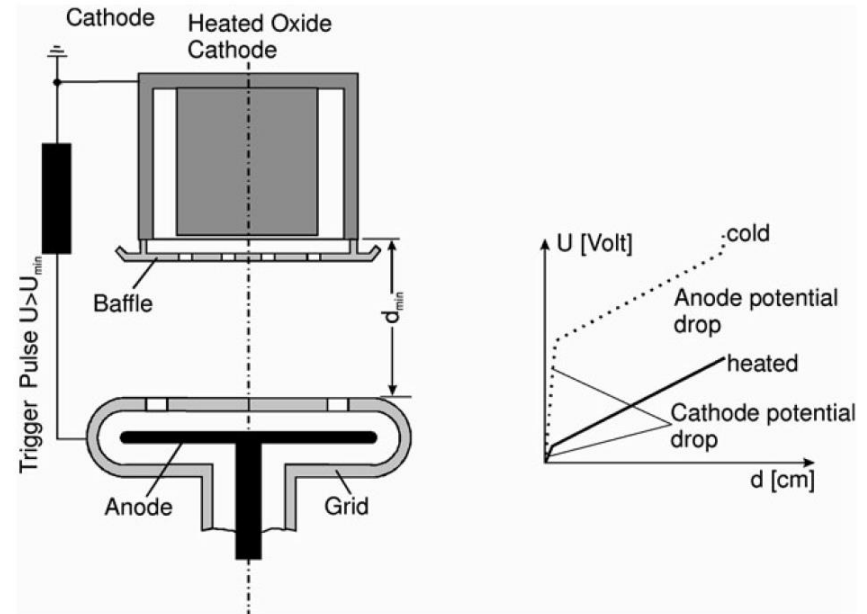

Thyratrons



- **Operating voltage:** several times 10 kV. After ignition: ~ 100 V \Rightarrow an appreciable power loss occurs and need to be dealt with by cooling.
- **Delay:** ~ 200 ns; jitter: \sim ns.
- **Operating times:** 10^5 hours;
Repetition rates: few kHz;
Operating power: MW.
- **To regain the initial hold-off voltage:** anode voltage must become slightly negative for 25-75 us for plasma to decay.

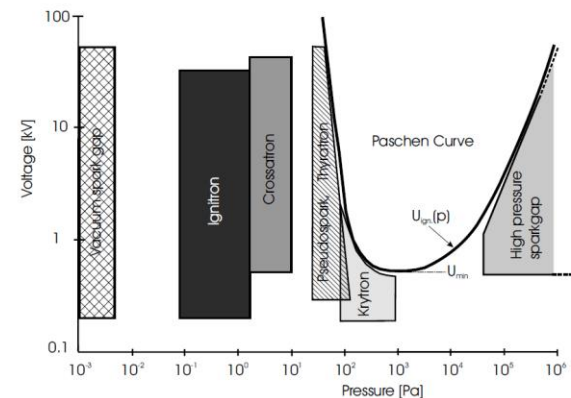
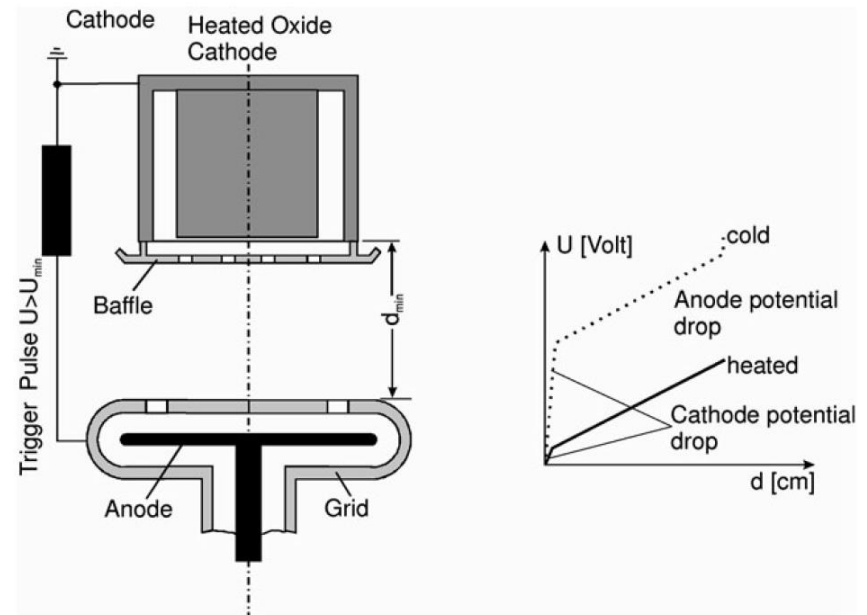

Thyratrons



- A thermionic cathode is used in a thyatron.
- Advantage: absence of a marked cathode potential drop using hot cathode.
- If cold cathode is used, potential drop is needed to accelerate the ions for secondary-electron production => lead to erosion of the cathode and thus the lifetime.
- A baffle is used as a screening element to avoid electron directly reaching the anode and causing the damage. It is shifted relatively to the grid to prevent a direct line of sight between cathode and anode.

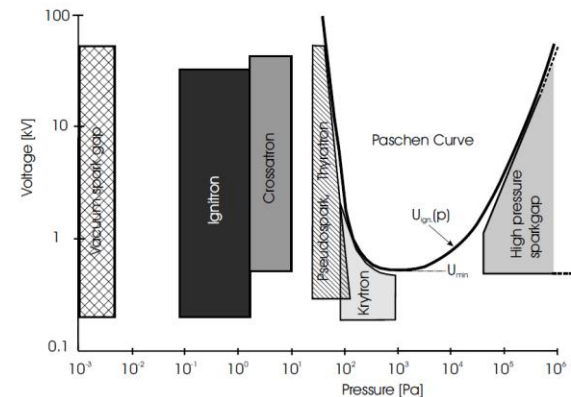
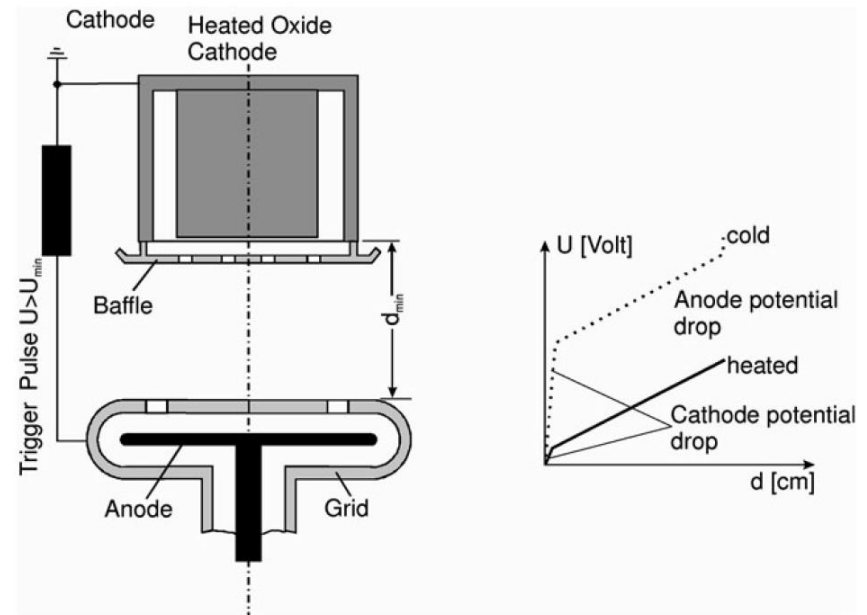

The pseudospark switch



- The pseudospark switch operates in a low-pressure regime, where the mean free path of electrons and ions become comparable to the electrode spacing. Most electrons reach the anode without any ionizing collisions in the gas.
- Hollow cathode: increases the possible discharge path lengths.
- The diameter of the aperture determines the field penetration into the hollow cathode.

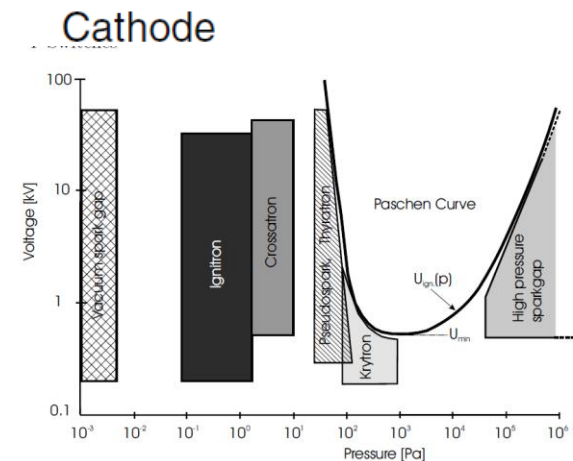
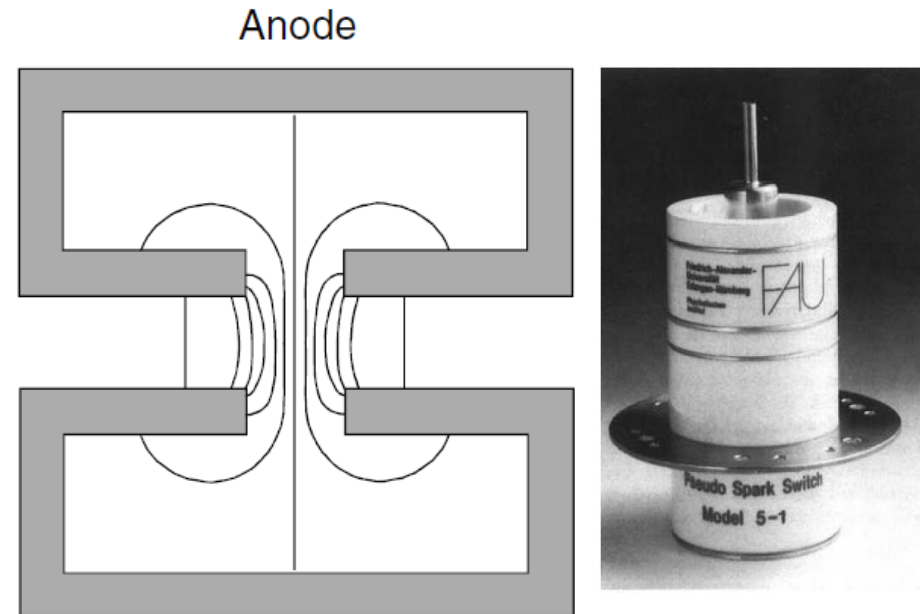

The pseudospark switch



- A small number of initial electrons, triggered discharge in the hollow cathode can initiate the pseudospark discharge.
- The switching mechanism is based on the build-up of a highly ionized plasma.
- plasma build-up occurs first inside the hollow cathode where E/P is low.

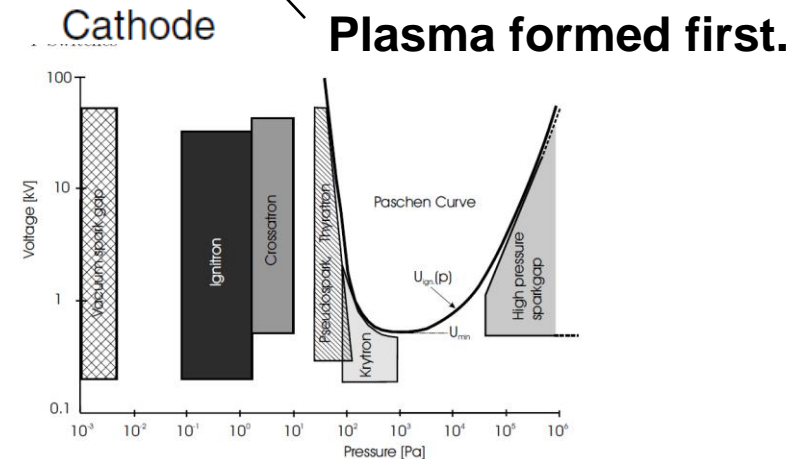
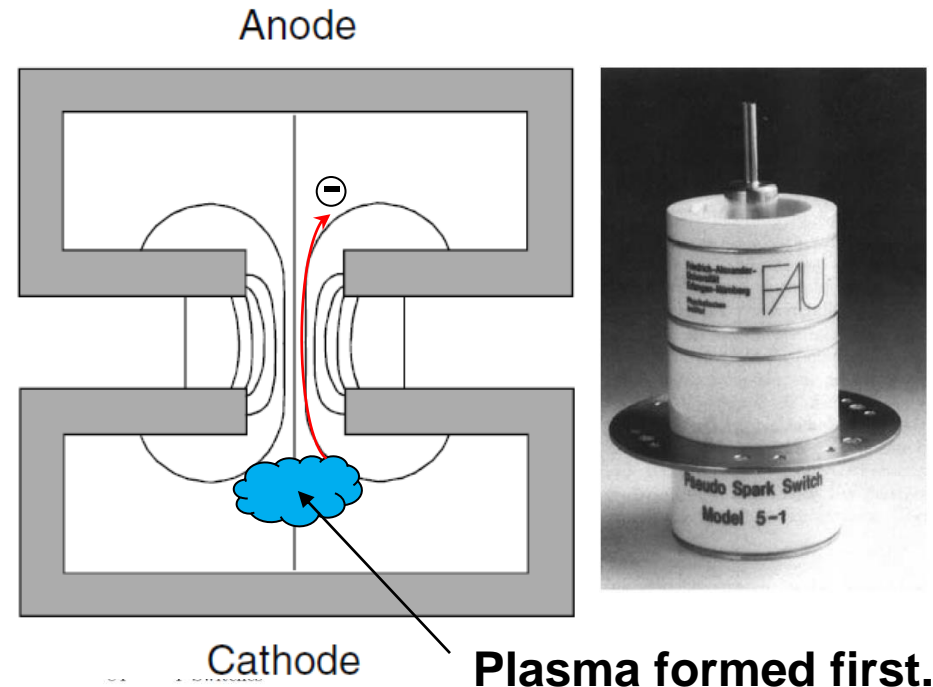

The pseudospark switch



- Ions drift back into the hollow cathode => forming a positive space charge (virtual anode).
- Static electric field inside the hollow cathode is distorted.
- Electron production rate > loss rate in the hollow cathode and subsequently in the anode-cathode gap.
- A low-resistivity plasma is established, and breakdown of the gap occurs.
- Jitter: 10 ns; Delay: 0.5 us.
- Advantage: high di/dt , reverse current, long lifetime, low jitter.

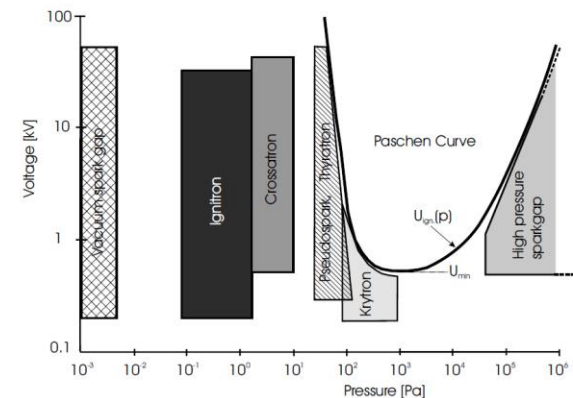
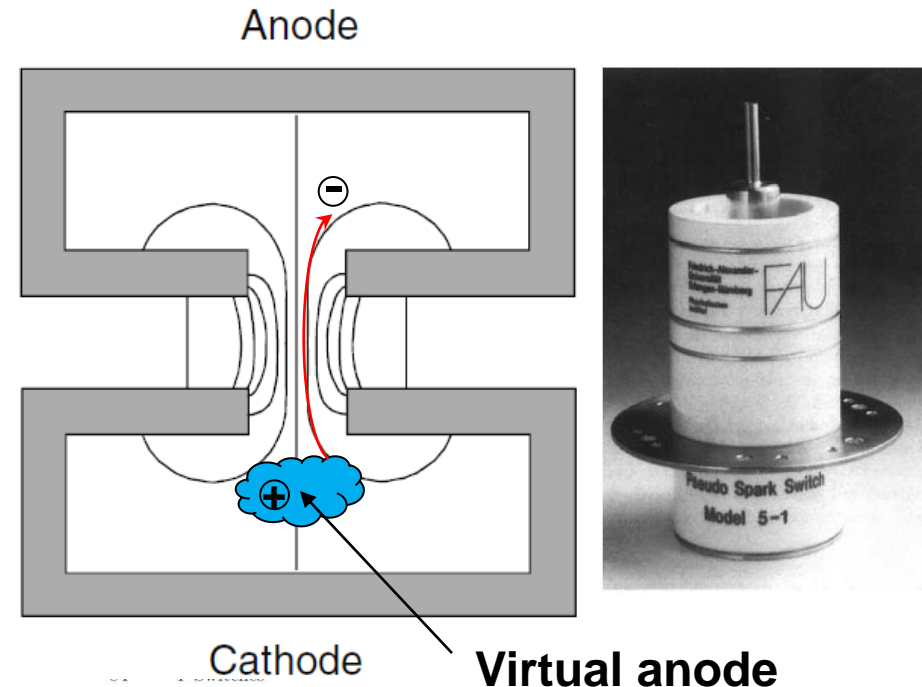

The pseudospark switch with triggering system

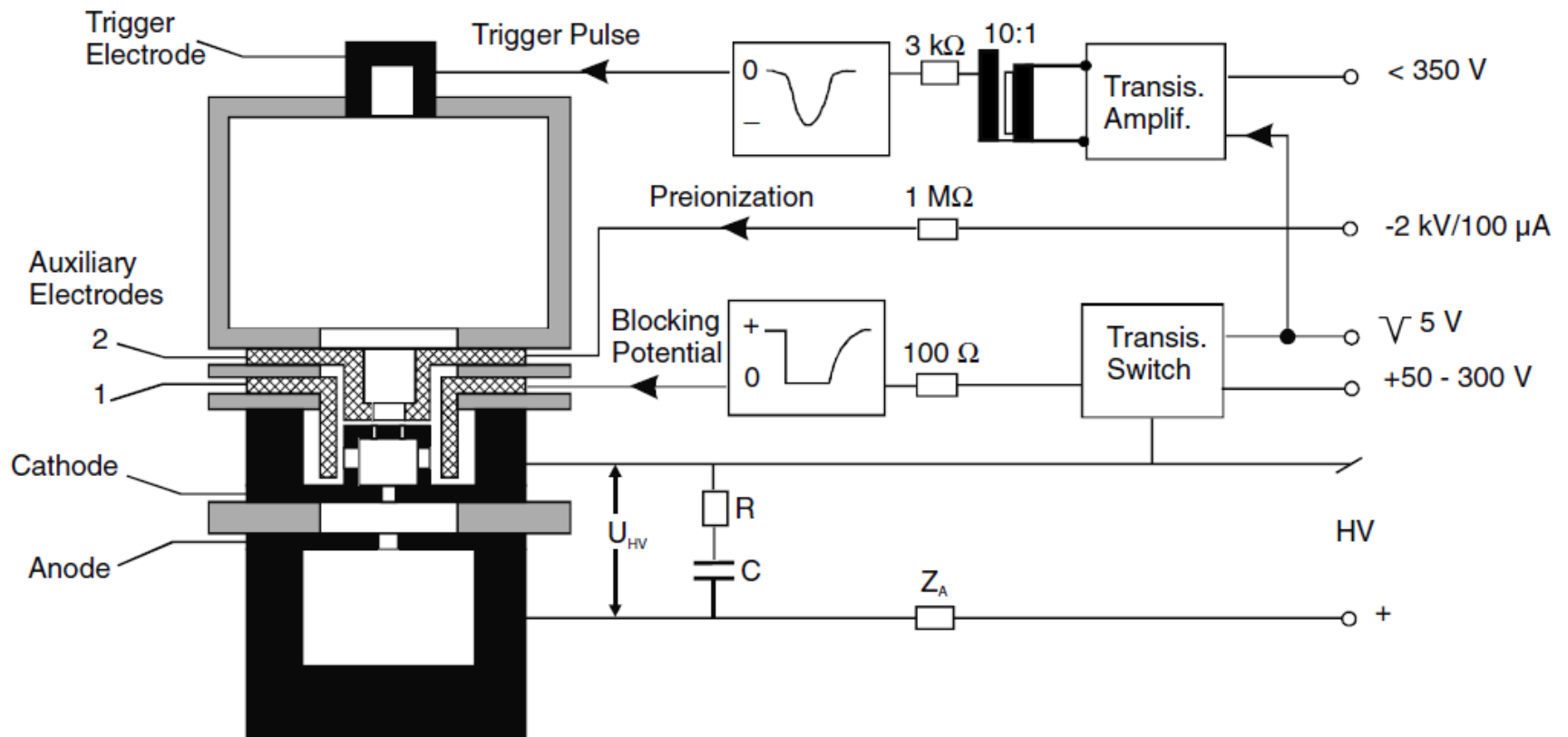

Ignitrons



- Ignitron is a very high-current, high-voltage switch with
 - a liquid mercury pool cathode
 - an ignitor pin dipping into the liquid-metal reservoir.
- Internal mercury pressure: ~ 5 Pa
- Can switch a pulse charge of up to 2000 Colum.
- Air/water cooled may be needed.
- Internal splash and deionization baffles may be contained in some devices.
- Anode:
 - Anode is massive to prevent an impulsive temperature rise during conduction.
 - Anode is cooled through
 - (1) anode stem;
 - (2) radiation to the cooled walls.

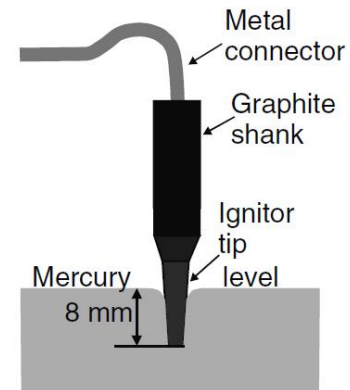
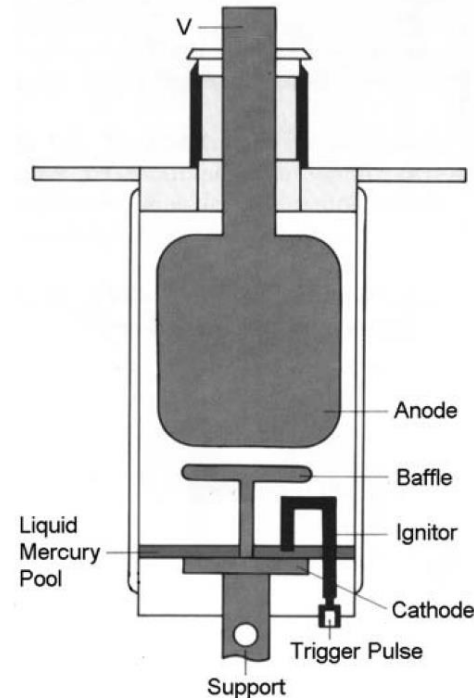

Ignitrons



- **Cathode:** a mercury pool at the bottom of the stainless steel tube.
- **Ignitor:** serves as the triggering electrode and is insulated from the cathode by a glass feedthrough.
- A high resistance forms at the mercury-ignitor interface.
- The electrical power in the ignitor circuit is mainly dissipated in a small volume near this interface. => creates an intense source of mercury vapor and free electrons => cathode hot spots spread over the entire mercury surface in ~50-100 ns. => mercury vapor pressure rises rapidly in the cathode-anode space. => pd value approaches the Paschen minimum => with free electrons, ionization avalanche develops.

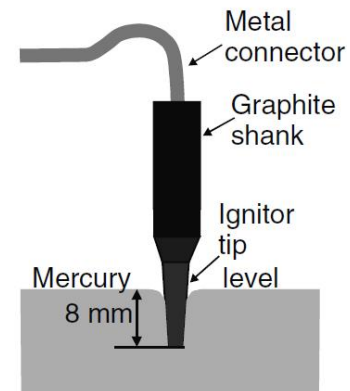
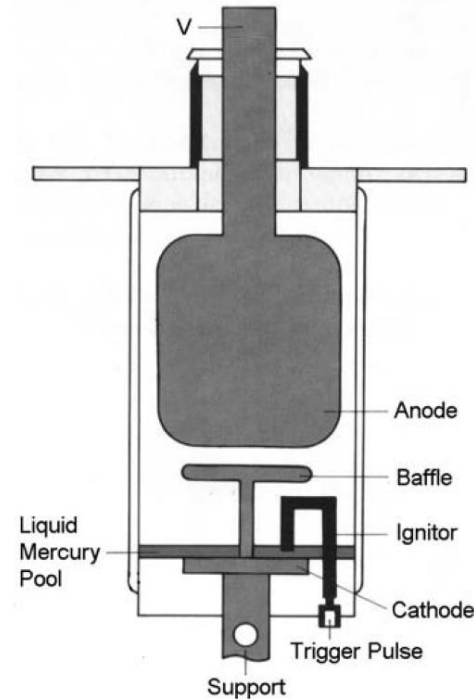

Ignitrons



- Rise time ~ 300-500 ns.
- After current drops below a critical value => no more additional vapor is produced => with additional time to allow recombination and recondensation of mercury.
- The mercury vapor must be forced to recondense back into the pool.
- Repetition rate ~1 Hz
- Progressively eliminated due to the mercury-containing waste.

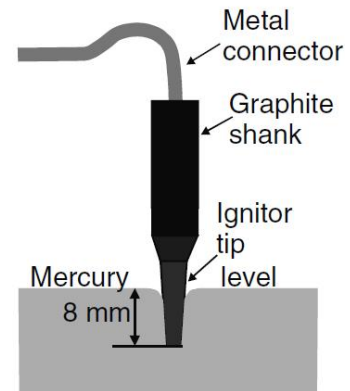
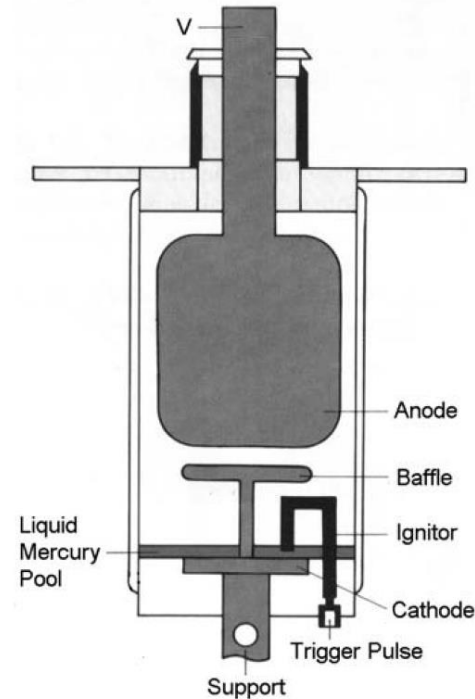

Krytrons



- **Low-pressure gas discharge device with a tetrode configuration, sealed in a glass tube with a cold cathode.**
- **1.3 kPa (9.75 torr) of helium gas.**
- **A special design of the anode-grid area + applied gas pressure => large hold-off voltage.**
- **An already existing plasma is created by a glow discharge between the special keep-alive electrode and the cathode.**
=> short trigger delay: ~30 ns.
- **Rise time: ~1 ns, V_{max} : 8kV, I_{max} : 3 kA.**
- **Pulse length ~10 us, repetition rate ~1 kHz**
- **A positive pulse at the control grid initiate the switch.**

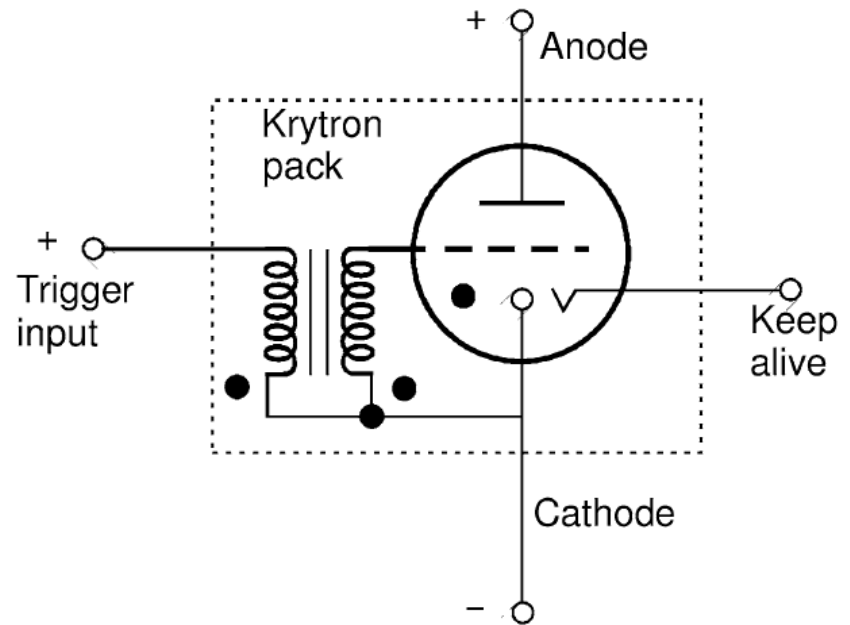

Krytrons



- A ^{63}Ni β -emitter may be enclosed to create a weak permanent pre-ionization.
- It is widely used in fast trigger generators and Pockels cell driver and also ideal for use in the detonating circuitry of bombs.

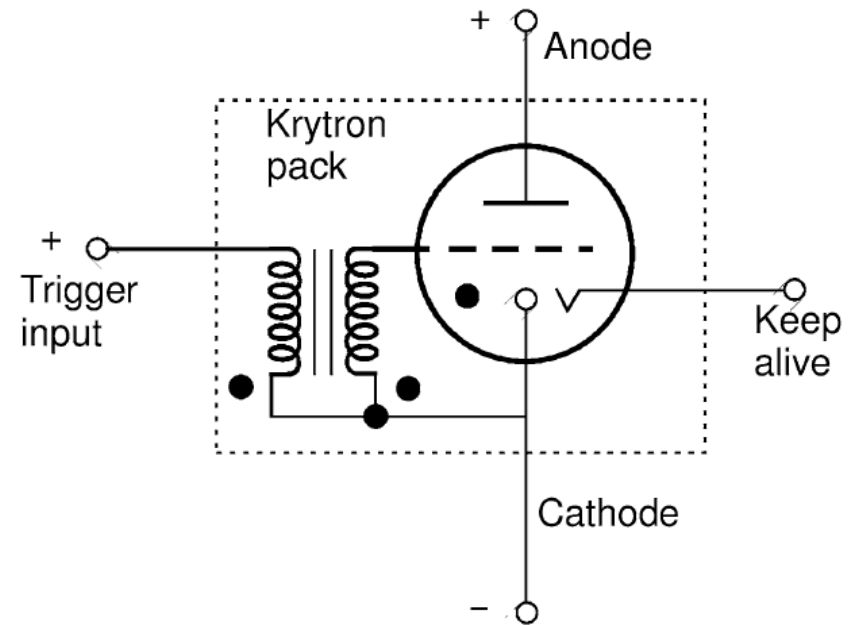

Triggered Vacuum Gap (TVG)



- A three-electrode system with $P=0.001$ Pa (7.5×10^{-6} Torr).
- Closed by injection of a plasma cloud.
- Hold-off voltage depends on the properties of the electrode surfaces.
- I up to 10 kA, V up to 100 kV. Repetition rates of several kHz are possible if cooled.
- The gas-plasma mixture is created with the help of an auxiliary arc, burning between two electrodes inserted into one of the main electrodes.
- Jitter ~ 30 ns; switching time ~ 100 ns.

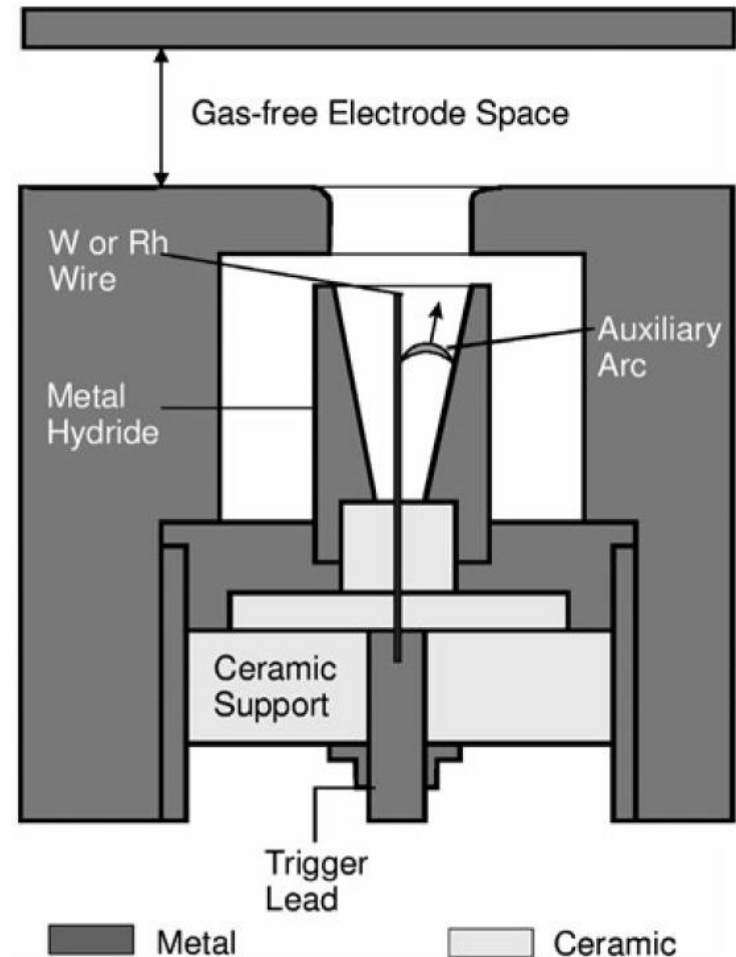

Semiconductor closing switches



- **The limiting switching characteristics of semiconductor devices are:**
 - **Relatively low mobility**
 - **Low density of charge carries**
 - **Comparatively low operating temperature**
- => Large volume of the conducting region is required to conduct large currents.**

Thyristors

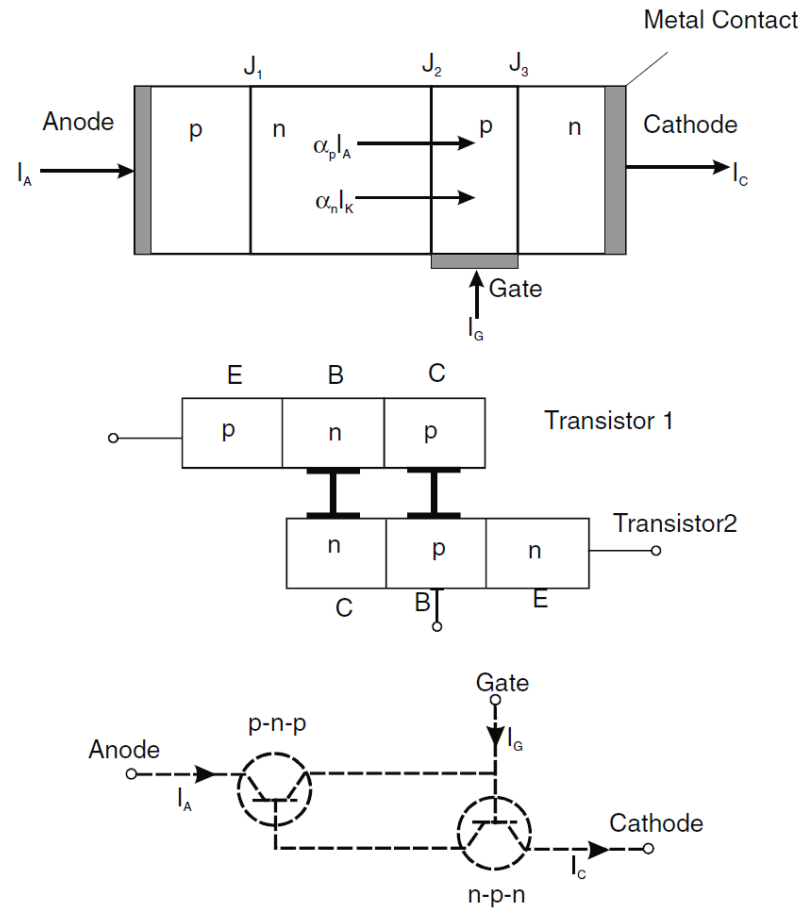
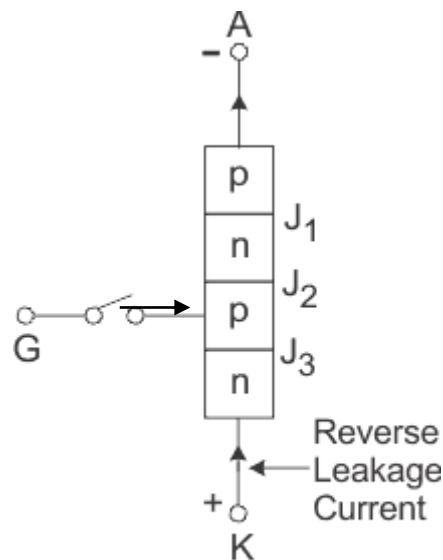

Fig. 4.22. Structure of thyristor, and two-transistor equivalent circuit

Thyristors



- Three modes of operation:
 - Reverse blocking state
 - Forward blocking state
 - Conduction or on state



Reverse Blocking Mode

Most of the voltage is held by J_1 .

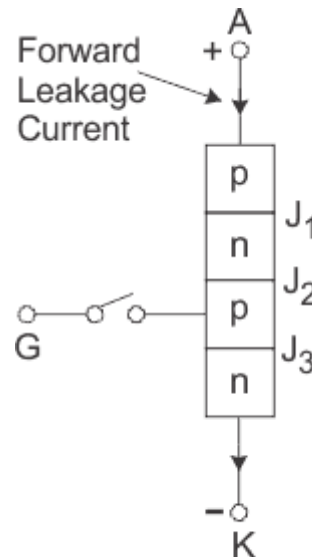

Forward Biased Condition

Most of the voltage is held by J_2 .

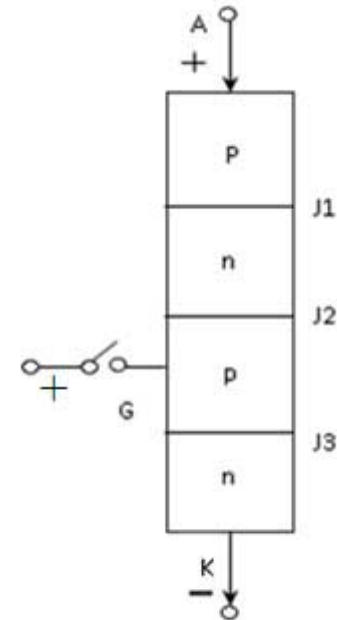
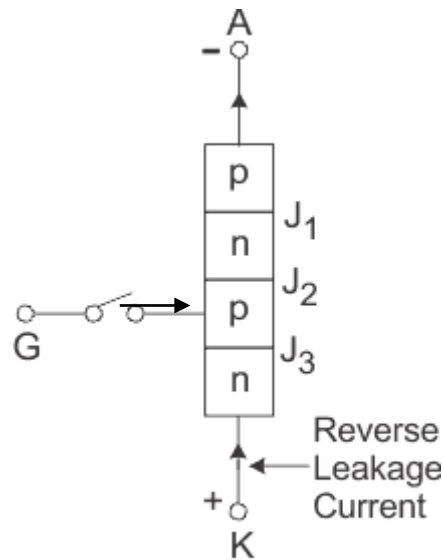

Fig 2: Forward Conduction

Thyristors



- Three modes of operation:
 - Reverse blocking state
 - Forward blocking state
 - Conduction or on state



Reverse Blocking Mode

Most of the voltage is held by J_1 .

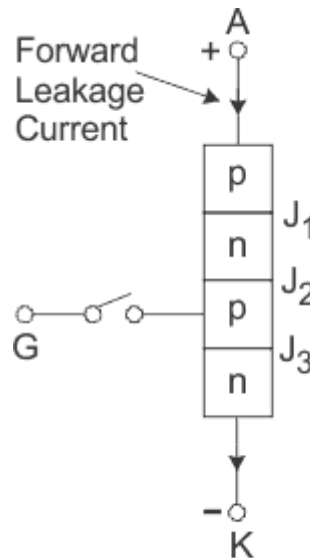

Forward Biased Condition

Most of the voltage is held by J_2 .

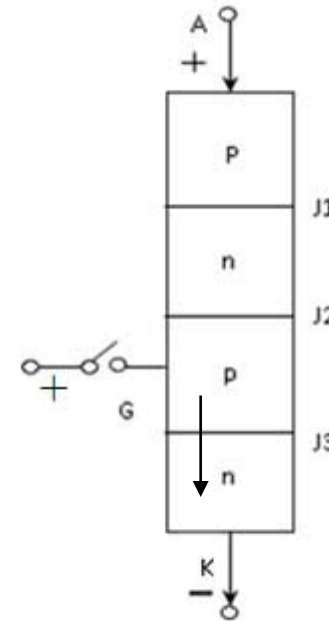

Fig2: Forward Conduction

e^- will fill up the holes



w/ more e^-
 \Rightarrow p type becomes N type

Thyristors



- Three modes of operation:
 - Reverse blocking state
 - Forward blocking state
 - Conduction or on state

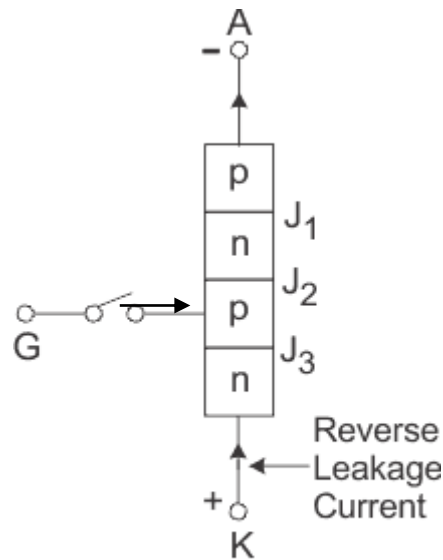

Reverse Blocking Mode

Most of the voltage is held by J_1 .

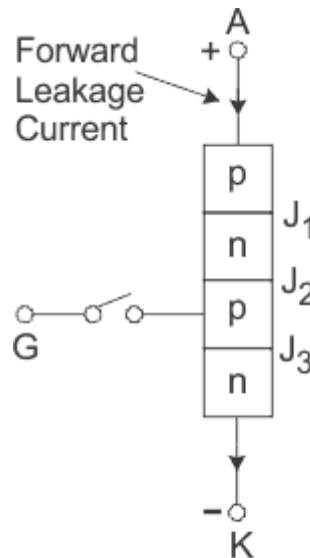

Forward Biased Condition

Most of the voltage is held by J_2 .

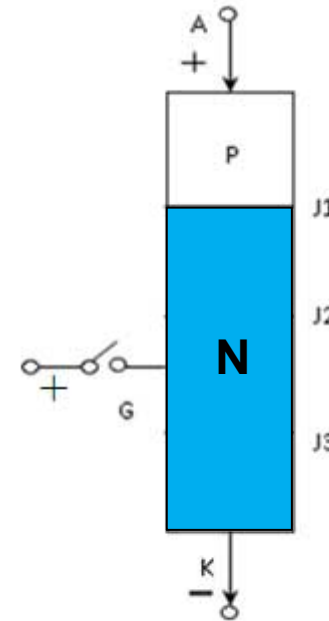



Fig 2: Forward Conduction

e^- will fill up the holes

w/ more e^- => p type becomes N type

Thyristors



- Without any external action, the thyristor cannot come back from the conducting to the blocking state.
- Two methods are generally applied:
 - Commutation of the current by polarity inversion.
 - Commutation of the current, supported by gate-assisted turn-off.

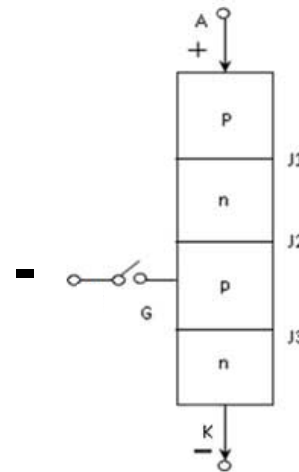
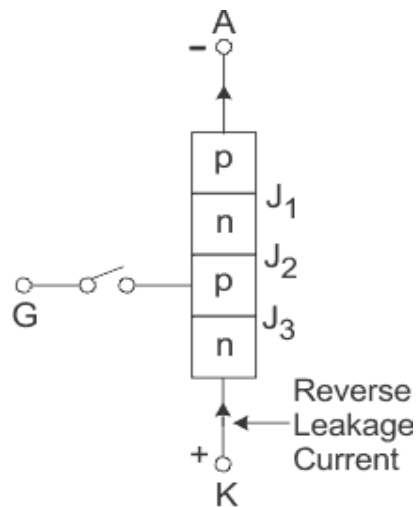
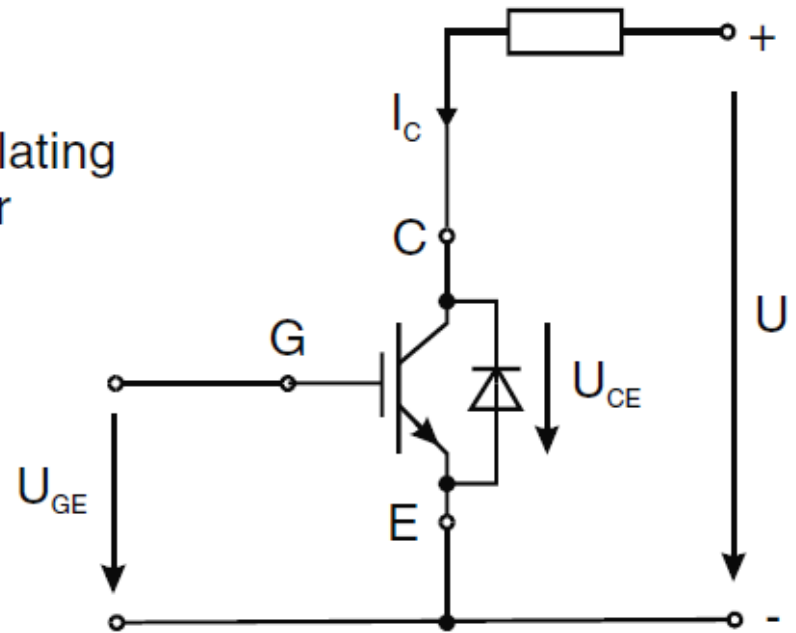
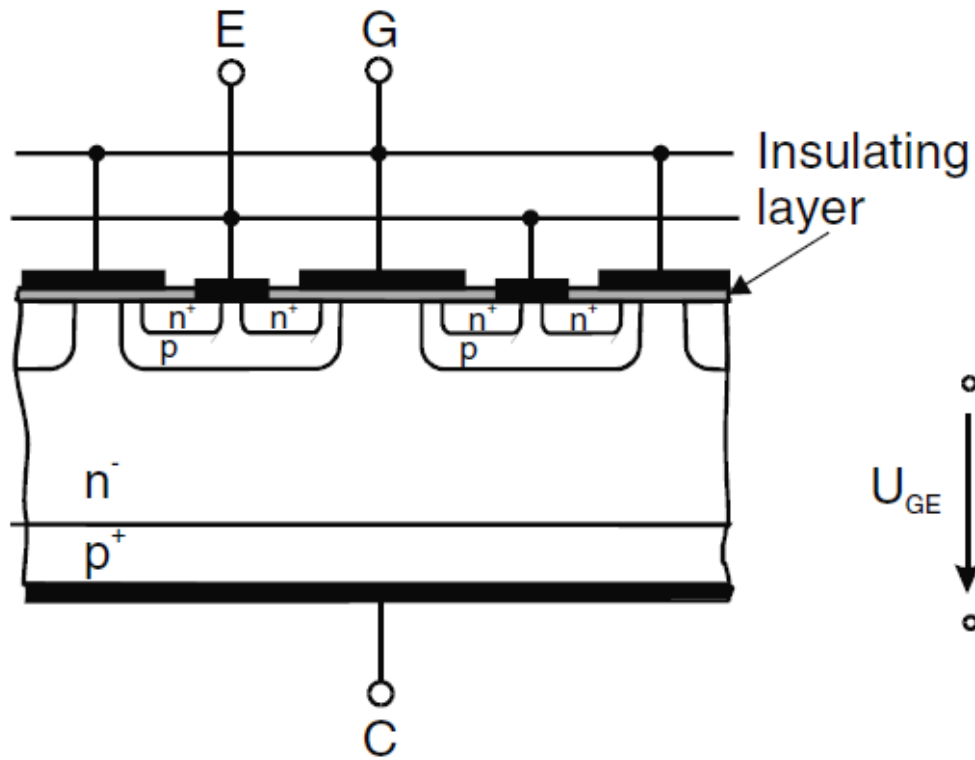

Fig 2: Forward Conduction

IGBT



IGBT



- **Advantage:**
 - **Bipolar transistors (BJT) – low resistance in the switched-on state**
 - **Field effect transistors (FET) – loss-free gate control**
- **Switch-on times:**
 - ~ several times 10 ns.
- **It has a limited reverse-blocking capability => an external diode is sometimes used in parallel.**
- **High-power IGBT: blocking voltages $V \sim 4$ kV, on state $I \sim 3$ kA**

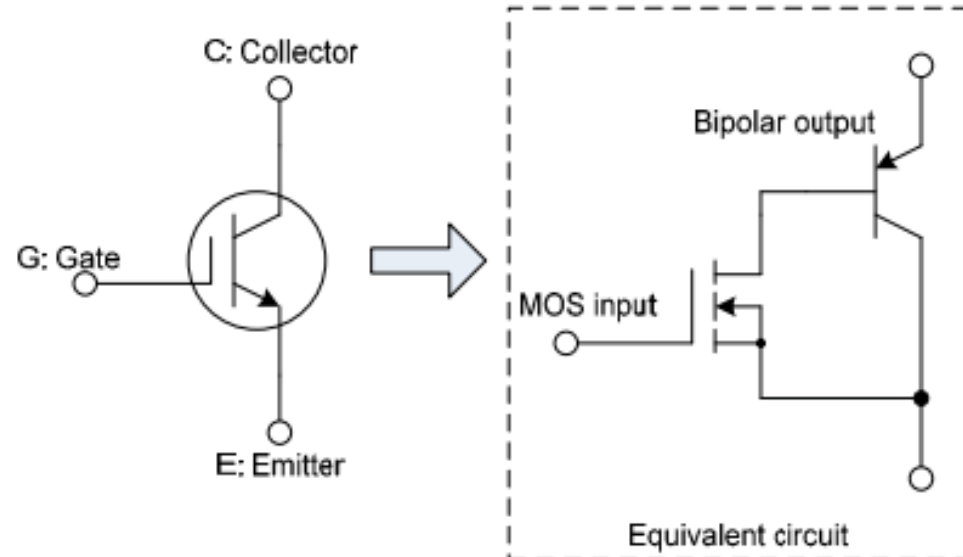

Optically activated semiconductor switches



$$\nabla j_n = e(R_n - G_n) + e \frac{\partial n}{\partial t}$$

$$\nabla j_p = -e(R_p - G_p) - e \frac{\partial p}{\partial t}$$

$$eG_{av} = \alpha_n |j_n| + \alpha_p |j_p|$$

R_n : recombination rate.

G_n : generation rate.

- Electron and hole generation is caused either by optical excitation or by avalanche ionization at sufficiently high electric fields.

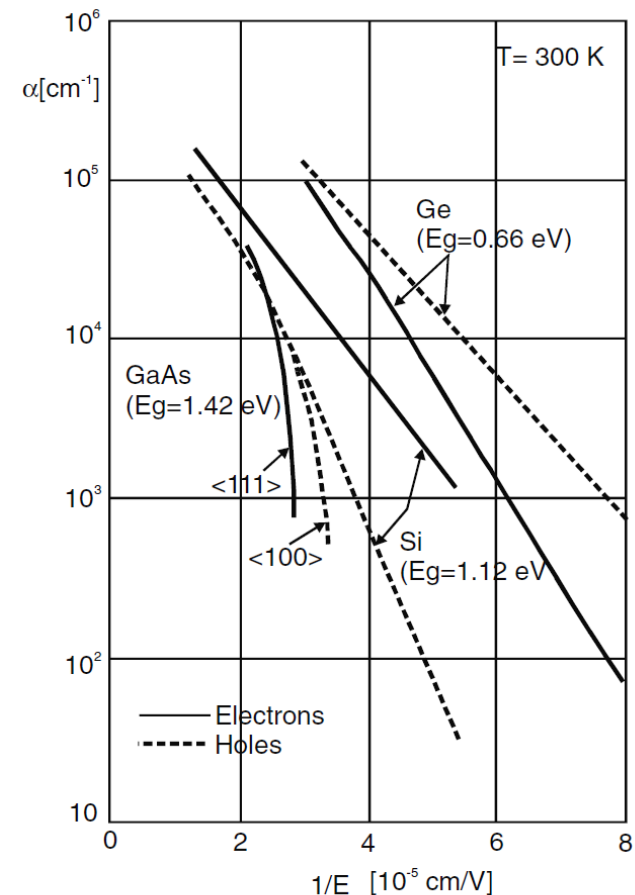
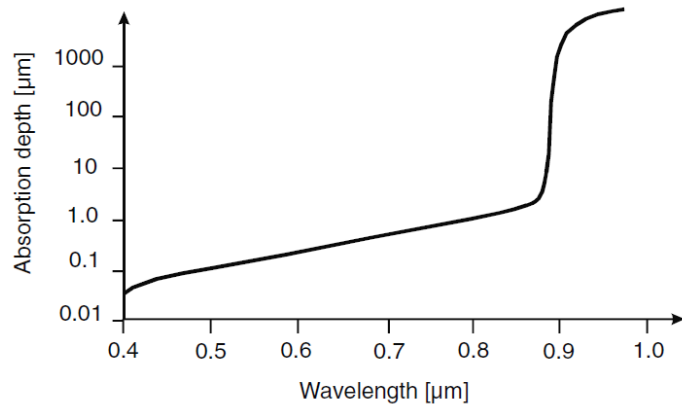

Fig. 4.31. Ionisation rate coefficients α_n and α_p

Optically activated semiconductor switches



- The wavelength should be larger than 0.9 μm . Therefore a Nd:YAG laser, wavelength = 1.06 μm , is an appropriate light source.

Fig. 4.32. Optical absorption depth in GaAs as a function of wavelength

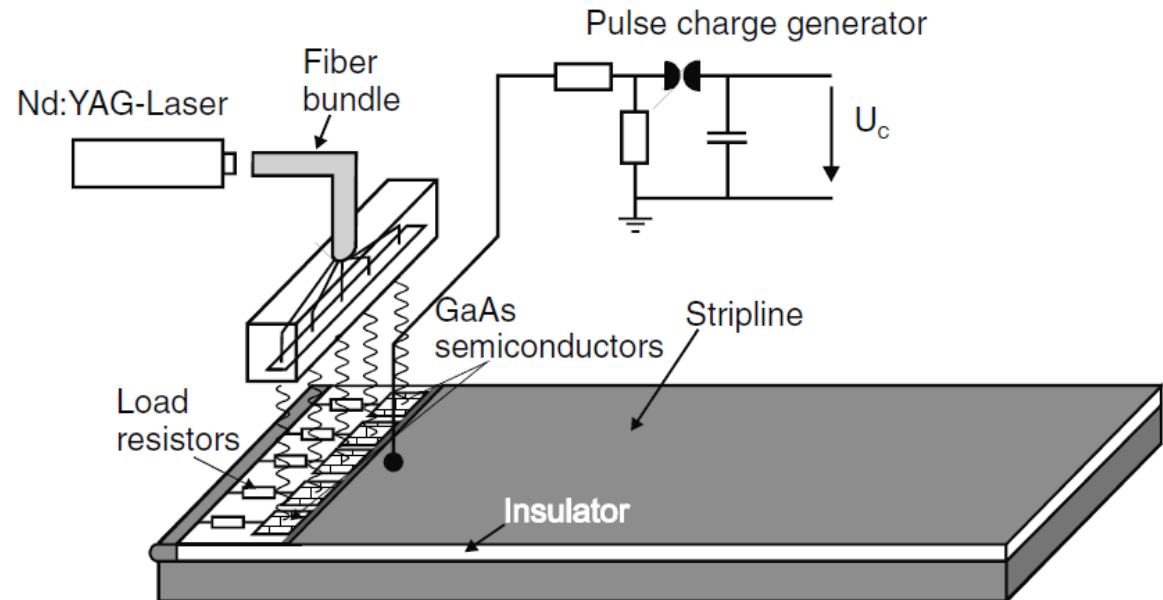

Optically activated semiconductor switches

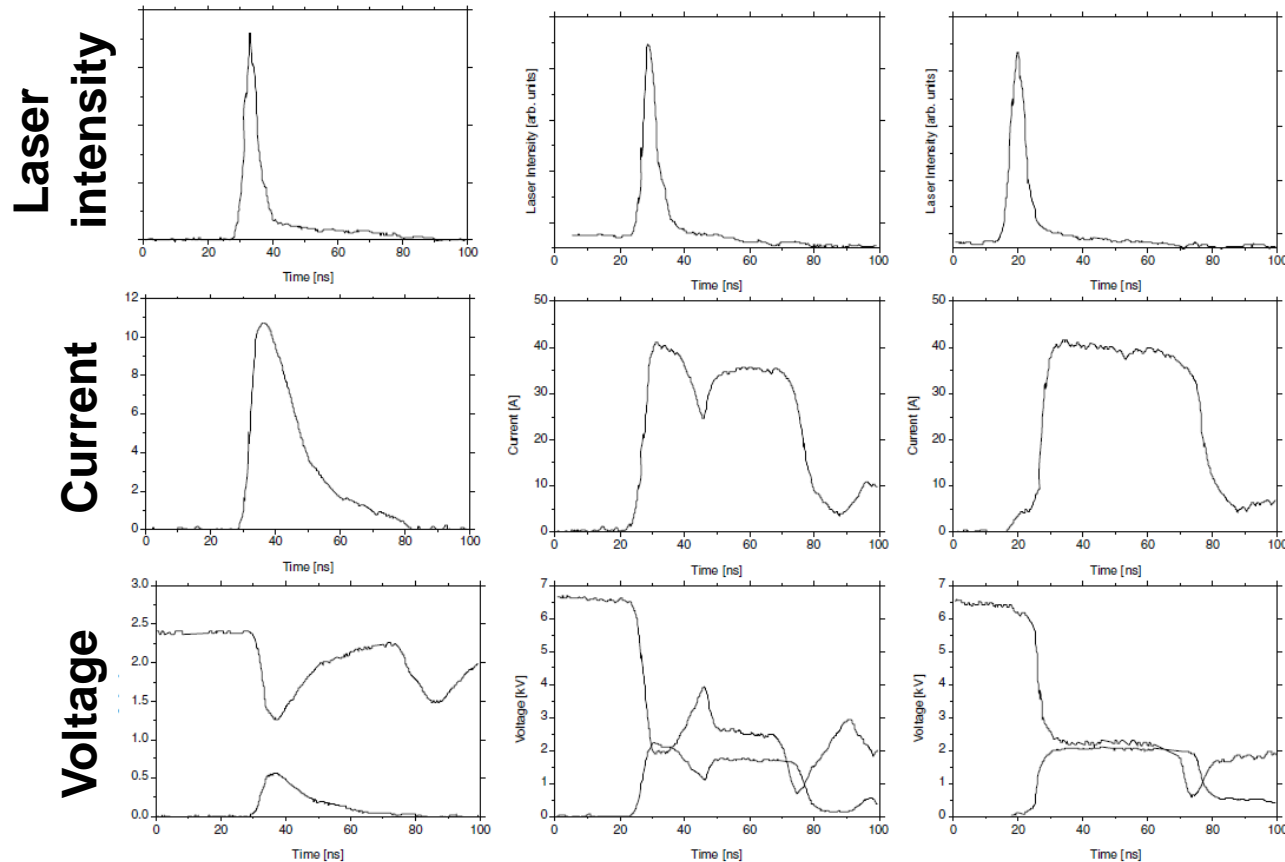

- **Linear photoconducting regime:** the available number of charge carriers is determined only by the laser intensity.
- **Nonlinear regime:** the number of charge carriers is increased by collisional ionization and as in a gas switch increases exponentially.

Magnetic switches

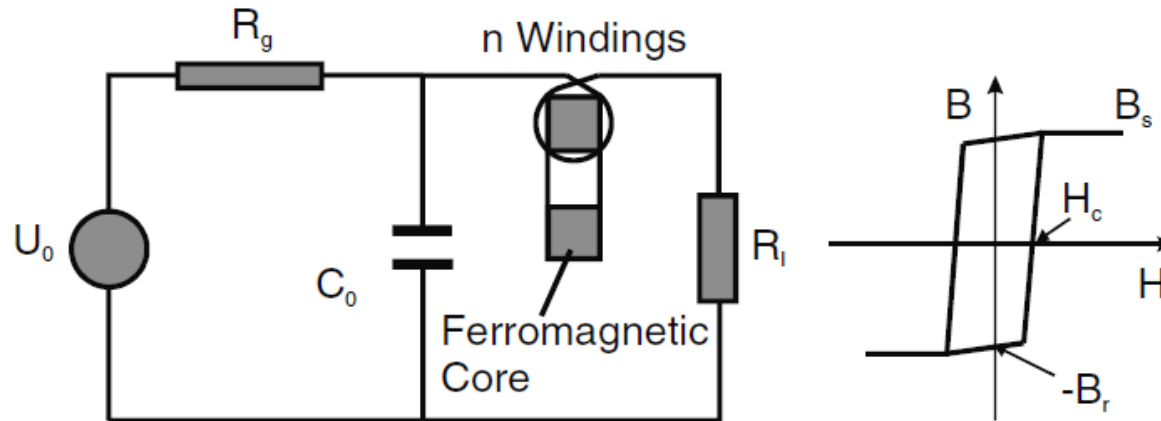

- Relatively small losses and without wear.
- While the capacitor is being charged: the coil has a ferromagnetic core with high inductance at the beginning: $V=Ldi/dt \Rightarrow$ like an open switch.
- When saturation of the core is reached by the leakage current flowing through the coil $\Rightarrow L$ drops abruptly by a factor of $\mu \Rightarrow$ switch is closed.
- $\mu=B/H \rightarrow 0$ when saturated.
- The hysteresis loop should approximate a rectangular form, with an abrupt change of the permeability over several orders of magnitude when the saturation point is reached.

Summary



Type	Hold-off potential (kV)	Peak current (kA)	Cumulative charge (A s)	Repetition rate (Hz) [commutation time (ns)]	Lifetime (number of pulses)	Remarks
Spark gap	1–6000	10^{-3} –1000	0.1–50	1–10 [1–1000]	10^3 – 10^7	Lifetime is determined by electrode erosion
Thyratron	5–50	0.1–10	10^{-3}	1000 [5–100]	10^7 – 10^8	Applied in lasers and accelerators
Ignitron	> 10	> 100	2000	1 [1000]	10^5 – 10^6	Applied in lasers and accelerators
TVG	0.5–50	1–10	40	1 [10–100]	$> 10^4$	
Pseudo-spark	1–50	1–20	1	1–1000 [> 10]	10^6 – 10^8	Similar to Thyratron
Krytron	8	3	0.01–0.1	< 1000 [1–10]	10^7	Very short delay and commutation time
Magnetic Switch	1000	100–1000		10 [5–10000]	10^8 – 10^9	Cannot be triggered; one operating point only
Thyristor	< 5	< 5	10^{-2}	10 [> 1000]	10^8	Can be stacked; expensive; complex
IGBT	< 4	3		100	10^8	Can be switched off
GaAs photoactivated switch	< 20	1–10	$< 10^{-4}$	< 10 [1–10]	10^2 – 10^3	Needs intense light source

Outlines



- **Switches**
 - Closing switches
 - **Opening switches**
- Pulse-forming lines
 - Blumlein line
 - Pulse-forming network
 - Pulse compressor
- Pulse transmission and transformation
 - Self-magnetic insulation
 - Pulse transformer
 - Voltage multiplier
 - H-bridge pulse generator
 - Fast high-voltage pulse generator

Opening switches



- An opening switch is characterized by “a sudden growth of its impedance” by
 - External actuator
 - Internal process – depend on the amount of the charge conducted through the switch
- The mechanism can be
 - Resistive nature: common fuse
 - Inductive nature: flux compression, $L(t) \gg L(0)$
 - Capacitive nature, $C(t) \ll C(0)$

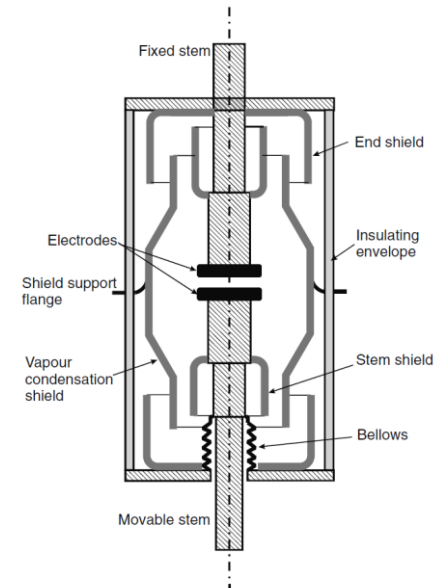

Opening switches



- **Requirement:**
 - **Long current conduction time.**
 - **Large current and small losses during conduction.**
 - **Fast impedance rise during opening.**
 - **High impedance after opening & large voltage hold-off during current interruption.**
 - **Short recovery time, i.e., high repetition rate capability.**
 - **Long lifetime, i.e., small wear.**

Fuses



- **Melting fuse – the most widely known opening switch.**
- **A thin wire / a foil embedded in a gaseous, liquid or granular medium.**
- **Based on Melting, Boiling, or Vaporization of a conductor,**
- **Fast opening is possible: <50 ns**
- **Conduction time can be determined by the type of material and its geometry.**

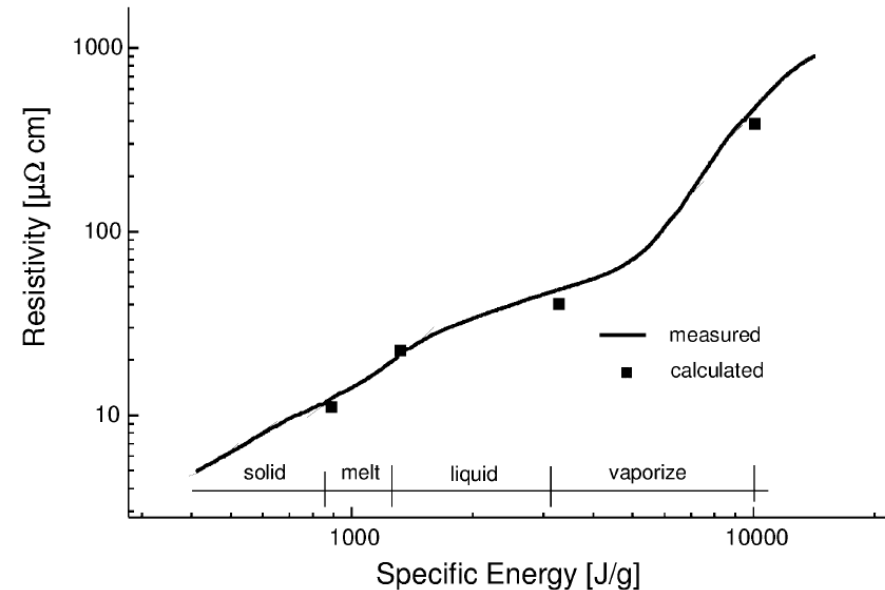

Fuses



- The resistivity of most metals rises continuously with T both in the solid and in the liquid phase.
- The high magnetic pressure associated with the current flowing through the fuse can maintain a high density and therefore metallic conductivity beyond the critical temperature.
- Only after the onset of expansion does the metallic conductivity disappear.

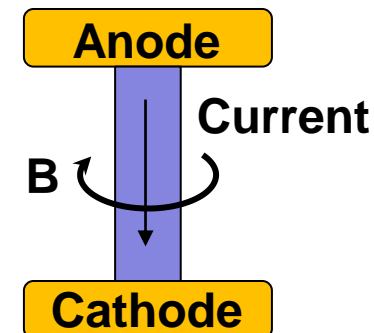
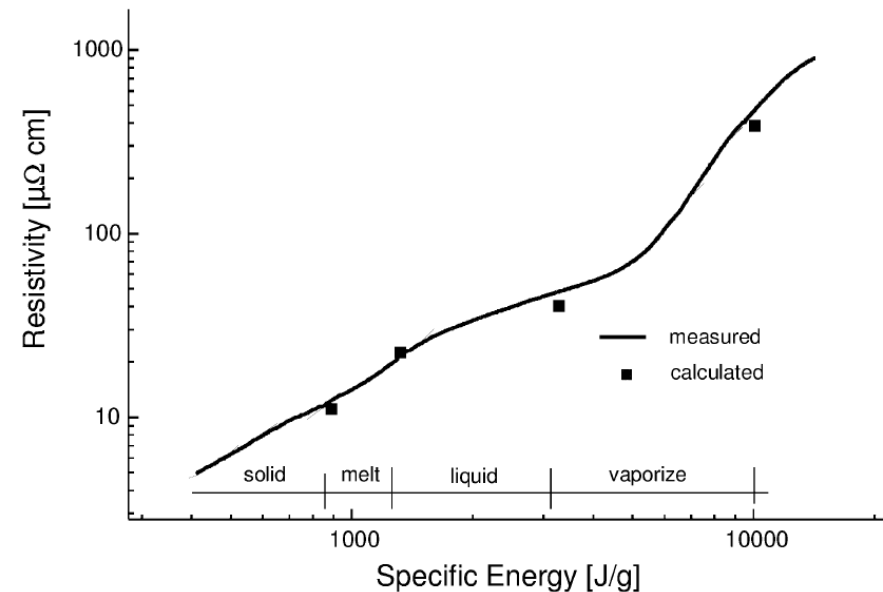

Fuses



- If the density of the metal vapor becomes sufficiently small -> electron avalanche processes can lead to the initiation of arcs in the vapor.
- The purpose of the surrounding medium is therefore to quench or prevent arc formation.
- Advantage – simplicity, adapt their parameters to the experimental conditions by choosing the appropriate cross-section, length, and #/ of elements.

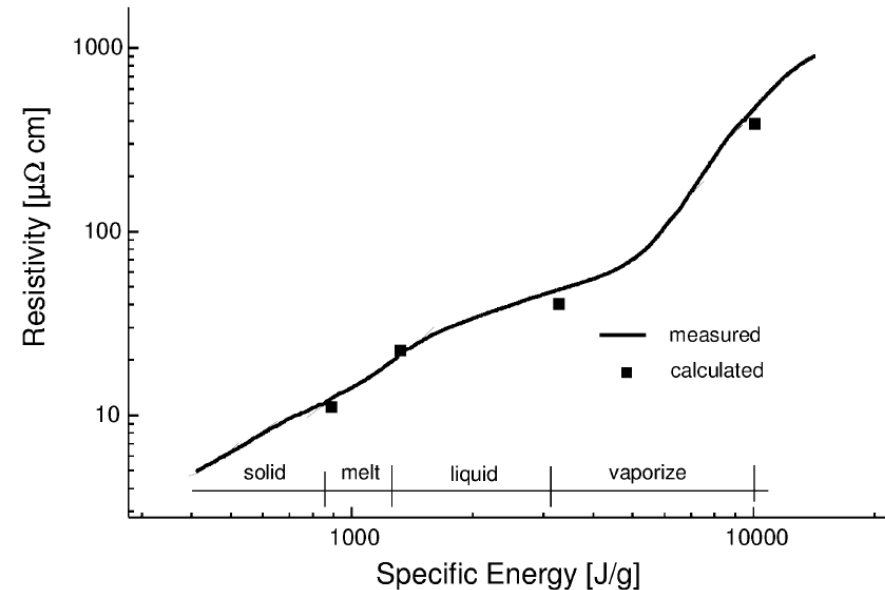

Anode



Arc may form.

Cathode

Mechanical Interrupters



- Vacuum interrupter switch: 2 planar/disc electrodes (1 fixed the other movable) in a vacuum envelope (0.1 Pa (7.5×10^{-4} Torr) or less).
- Closed position – low resistance (10-50 $\mu\Omega$) from a tight metal-to-metal contact
- Open position – separated by an actuator (致動器).
- During the process of switch breaking – an arc is likely to be drawn and sustained by metal vapor evaporated from the electrodes.
- In unipolar system, a current counter-pulse is needed to reduce the power input to the arc to allow the residual arc plasma to recombine.
- After $I=0$, $dU/dt=24$ kV/us is possible.
- Repetitive frequency – few tens of hertz.
- Opening speed – tens of us.

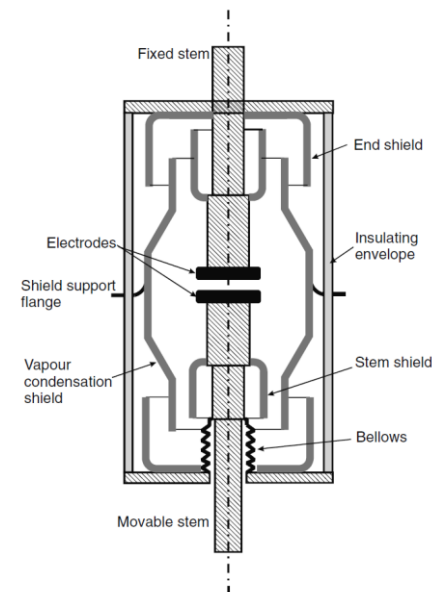

Counter-pulse arrangement

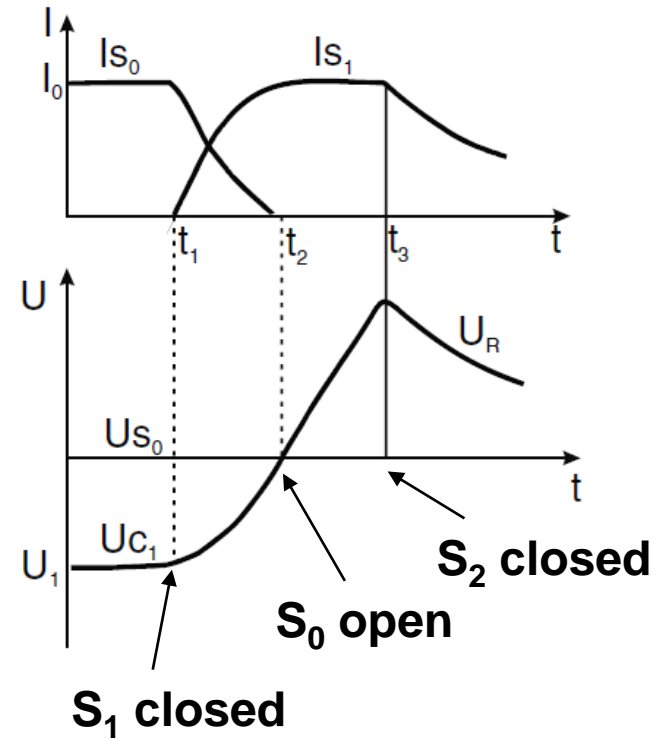
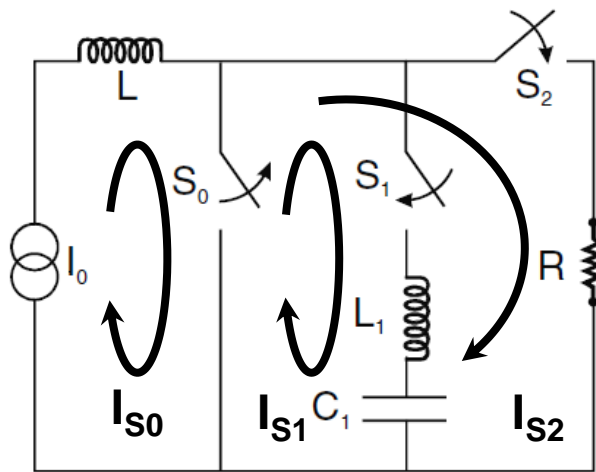

Superconducting opening switches



- Superconducting state -> normal conduction
- Three ways to trigger:
 - The current itself
 - An external pulsed magnetic field
 - pulse heating
- The repetition rate depends on the speed of recovery to the superconducting state.
- Problem: consists of the additional cooling necessary to remove the heat flowing into the cryogenic coolant during opening.

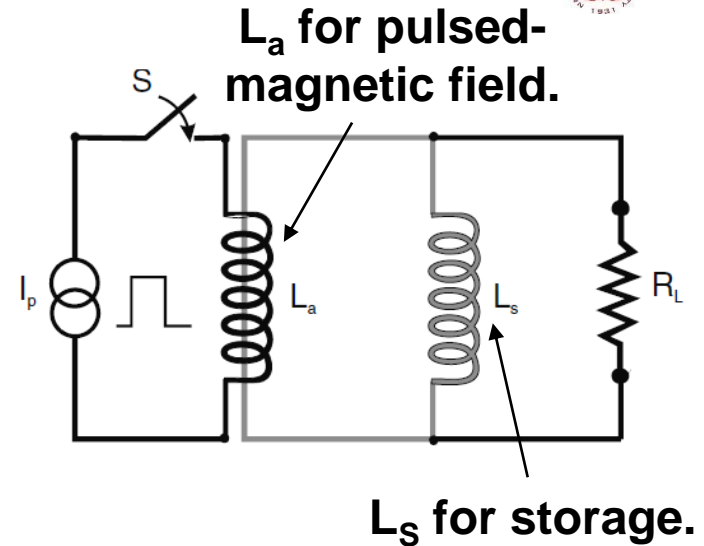

Plasma opening switches



- Suitable for high currents and short switching times.
- Plasma bridge of low density (10^{13} - 10^{15} cm⁻³).
- 10^{15} - 10^{16} cm⁻³ for several hundred kA or MA.
- 10^{13} cm⁻³ is needed to conduct currents for less than 100 ns and opening in less than 10 ns.

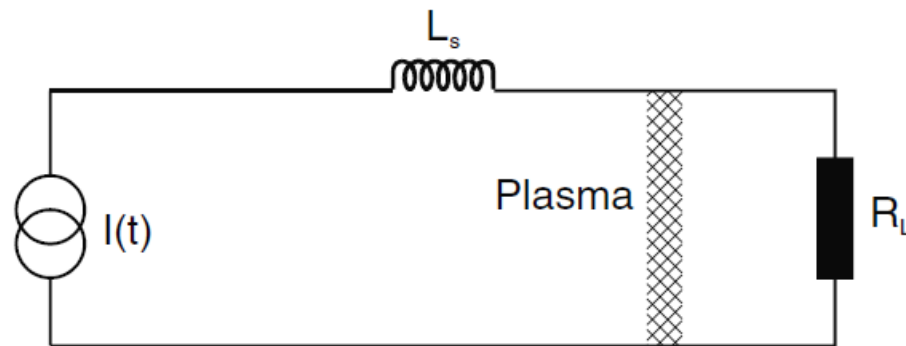

Coaxial system with an injected pulsed gas column

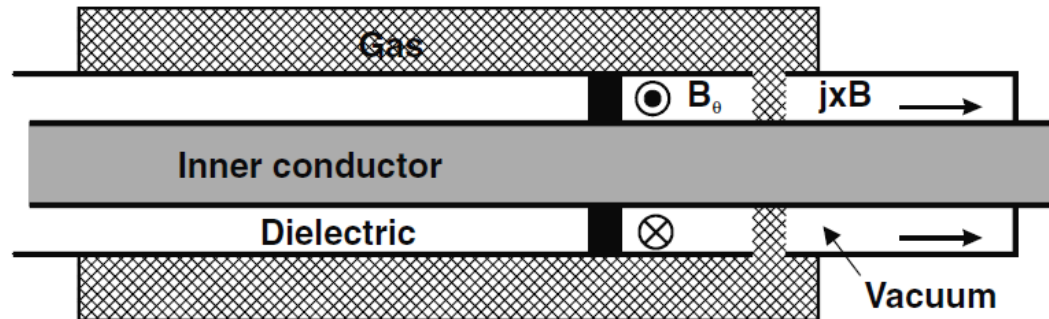

- The gas is made into a plasma by an auxiliary electric pulse before the coaxial inductor is charged.
- Conduction phase – the current, the magnetic field penetrates into the plasma
- Opening – occurs if the plasma becomes pushed out determined by self-magnetic insulation

Self-magnetic insulation process

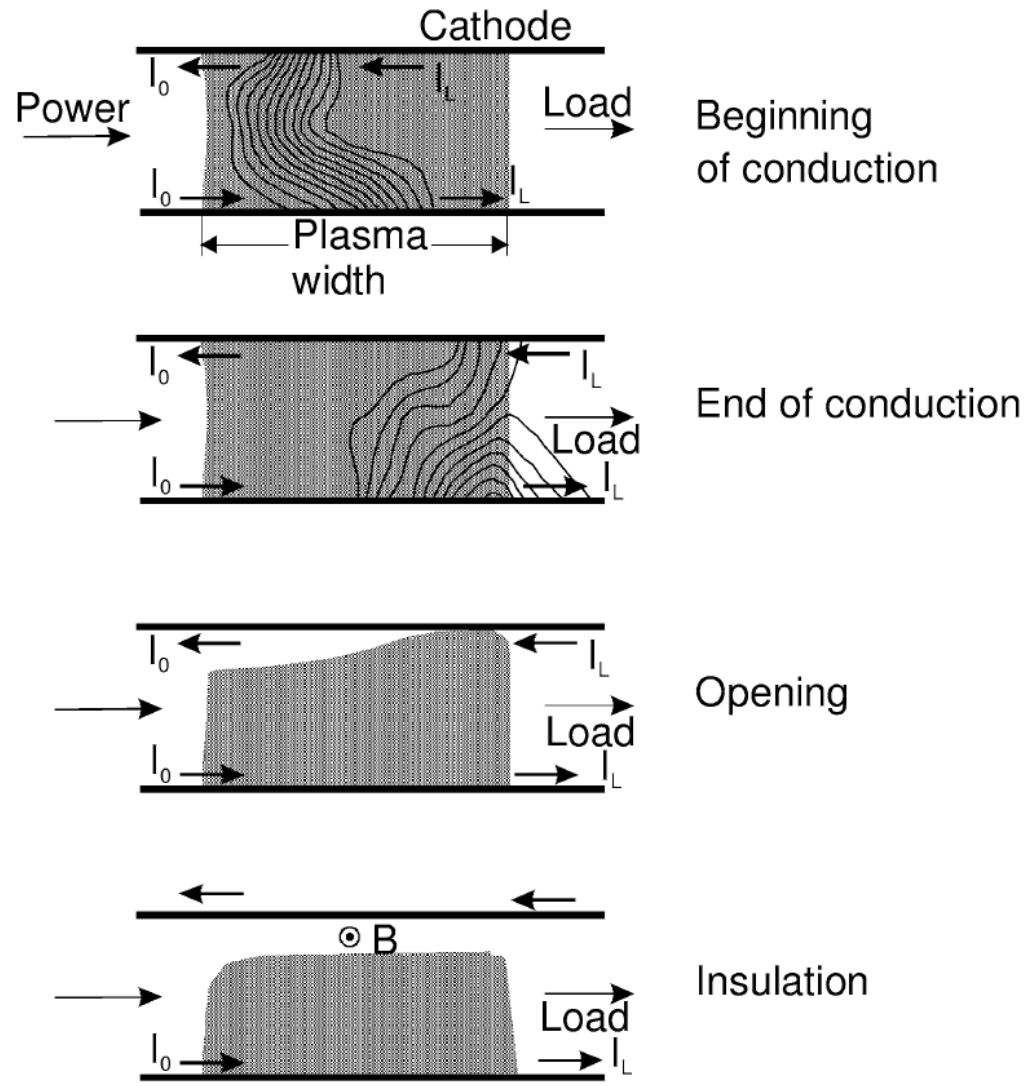

Plasma Flow Switches



- Higher plasma densities (10^{15} cm^{-3}).
- Conduction times – μs .

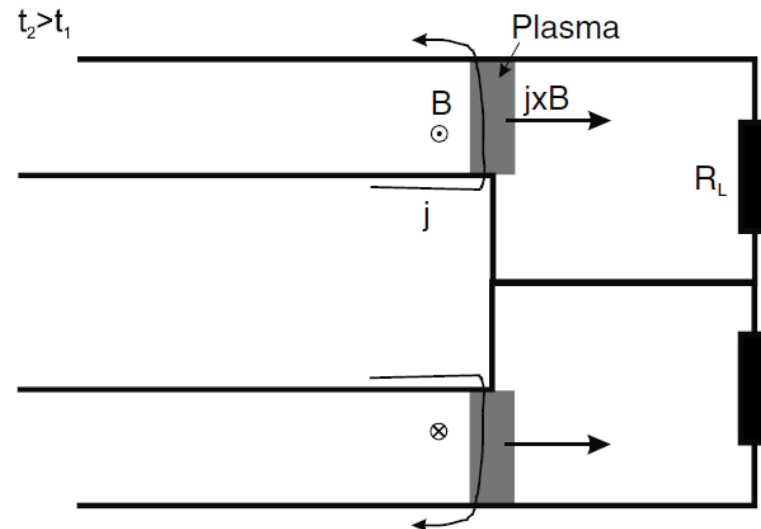
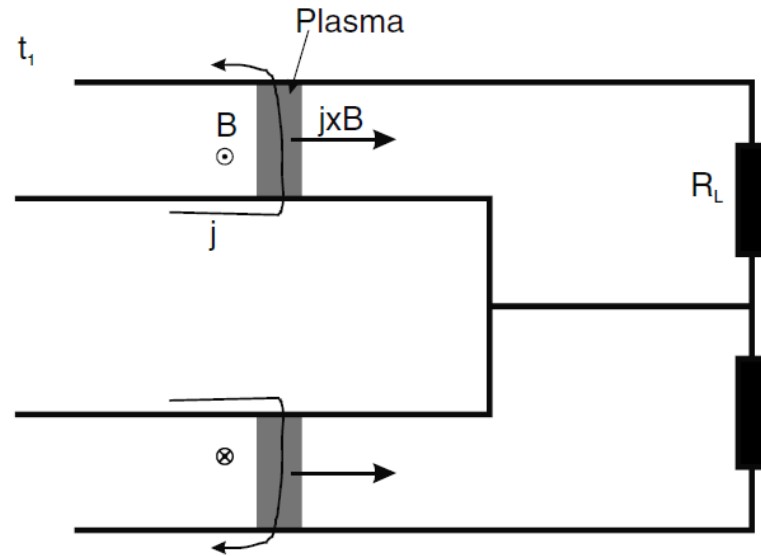

Outlines



- **Switches**
 - Closing switches: the switching process is associated with voltage breakdown across an initially insulant element.
 - Opening switches: the switching process is associated with a sudden growth of its impedance.
- **Pulse-forming lines**
 - **Blumlein line**
 - Pulse-forming network
 - Pulse compressor
- **Pulse transmission and transformation**

Pulse-forming lines



- **A constant-voltage plateau is needed for many pulsed-power applications.**
- **Various arrangements of LC elements are necessary. It is called “Pulse-Forming Networks (PFN)”.**

Transmission lines



- Transmission lines are the continuous borderline case of a network consisting of discrete LC elements.
- Depending on the time T during which energy is extracted from or supplied to the element, a transmission line can be described as lumped circuit element or an extended object.
 - $T > T_{\text{travel}}$, the time it takes for an EM wave to move from one terminal of the element to the next \rightarrow lumped circuit element.
 - $T < T_{\text{travel}}$, the time it takes for an EM wave to move from one terminal of the element to the next \rightarrow Transmission line.

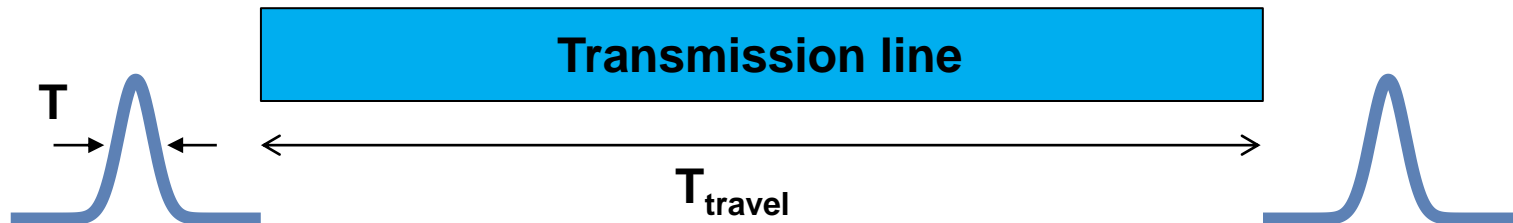

Different kinds of transmission line and the inductance and the capacitance per unit



1. Coaxial transmission line:

$$C' = 2\pi\epsilon / \ln(r_o/r_i)$$

$$L' = (\mu/2\pi) \ln(r_o/r_i)$$

$$Z_0 = \left((\mu/\epsilon)^{1/2} / 2\pi \right) \ln(r_o/r_i)$$

$$= 60(\mu_r/\epsilon_r)^{1/2} \ln(r_o/r_i)$$

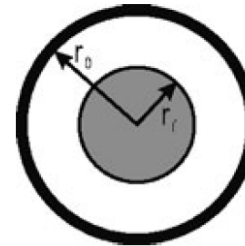

2. Double-wire line:

$$C' = \pi\epsilon / \operatorname{arcosh}(D/d)$$

$$L' = (\mu/\pi) \operatorname{arcosh}(D/d)$$

$$Z_0 = \left((\mu/\epsilon)^{1/2} / \pi \right) \operatorname{arcosh}(D/d)$$

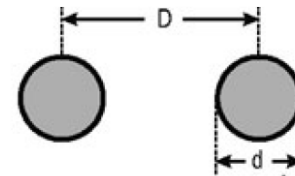

3. Parallel-plate line:

$$C' = \epsilon D/d$$

$$L' = \mu d/D$$

$$Z_0 = (\mu/\epsilon)^{1/2} (d/D)$$

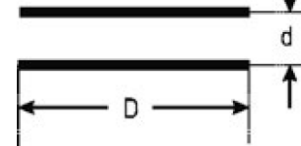

4. Stripline:

$$C' = 2\epsilon D/d$$

$$L' = \mu d/2D$$

$$Z_0 = (\mu/\epsilon)^{1/2} (d/2D)$$

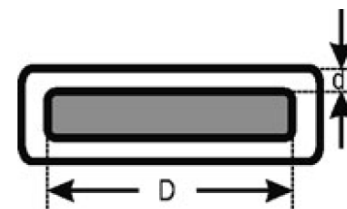

An infinitesimal section of a homogeneous coaxial transmission line

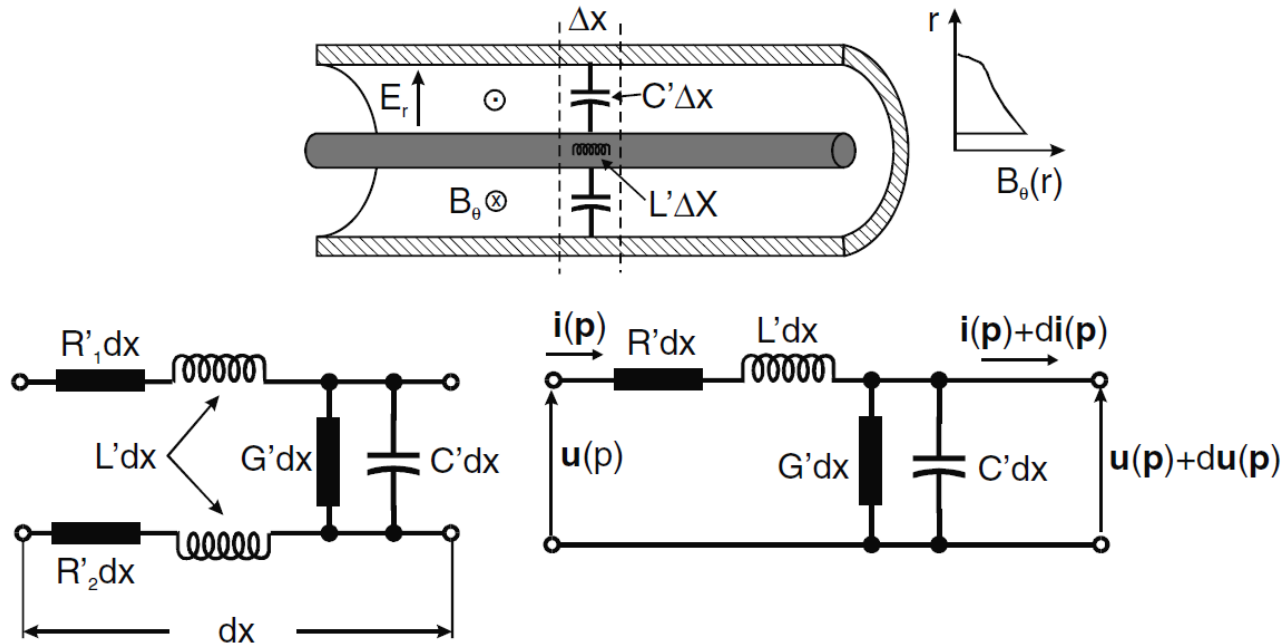

- Resistances per unit length: $R'_1 + R'_2 \rightarrow R' \rightarrow R$.
- Conductance per unit length: $G' \rightarrow G$.
- All quantities are frequency-dependent because of the skin effect and because the dielectric constant depends on the frequency.
- Assume that they are independent of the position x , the voltage V and current I .

An infinitesimal section of a homogeneous coaxial transmission line

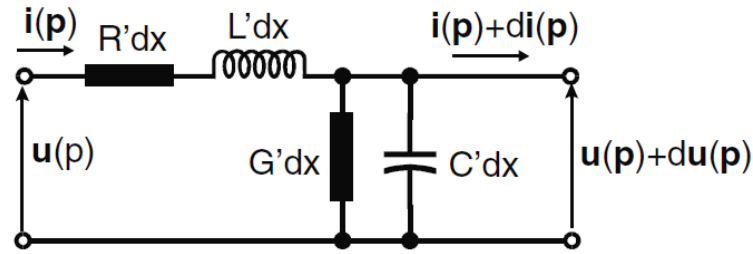

$$U - IRdx - Ldx \frac{dI}{dt} - U' = 0$$

$$I - U'Gdx - Cdx \dot{U}' - I' = 0 \quad U' = U + \frac{\partial U}{\partial x} dx \quad \dot{U}' = \dot{U} + \frac{d}{dt} \left(\frac{\partial U}{\partial x} \right) dx$$

$$I - \left(U + \frac{\partial U}{\partial x} dx \right) Gdx - Cdx \left[\dot{U} + \frac{d}{dt} \left(\frac{\partial U}{\partial x} \right) dx \right] - I' = 0$$

$$I - UGdx - \frac{\partial U}{\partial x} Gdx^2 - \dot{U}Cdx - \frac{d}{dt} \left(\frac{\partial U}{\partial x} \right) Cdx^2 - I' = 0$$

$$I - UGdx - Cdx \dot{U} - I' = 0$$

$$\begin{cases} \frac{U' - U}{dx} \equiv \frac{\partial U}{\partial x} = -RI - LI \\ \frac{I' - I}{dx} \equiv \frac{\partial I}{\partial x} = -GU - C\dot{U} \end{cases}$$

An infinitesimal section of a homogeneous coaxial transmission line



$$\left\{ \begin{array}{l} \frac{U' - U}{dx} \equiv \frac{\partial U}{\partial x} = -RI - LI \\ \frac{I' - I}{dx} \equiv \frac{\partial I}{\partial x} = -GU - CU \end{array} \right.$$

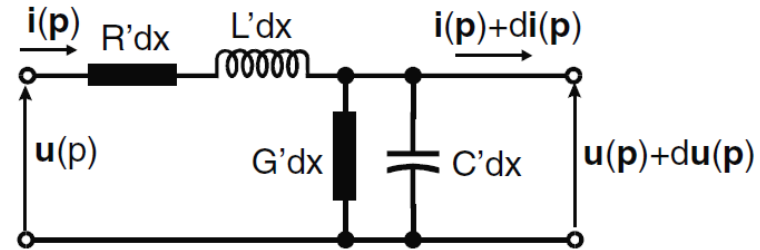

- Laplace transform: $x = \tilde{x}e^{pt}$, $\frac{d}{dt} \rightarrow p$

$$\frac{d\tilde{U}}{dx} = -R\tilde{I} - pL\tilde{I} = -(R + pL)\tilde{I}$$

$$\frac{d^2\tilde{U}}{dx^2} = -(R + pL)\frac{d\tilde{I}}{dx} = (R + pL)(G + pC)\tilde{U}$$

$$\frac{d\tilde{I}}{dx} = -G\tilde{U} - pC\tilde{U} = -(G + pC)\tilde{U}$$

$$\frac{d^2\tilde{I}}{dx^2} = -(G + pC)\frac{d\tilde{U}}{dx} = (G + pC)(R + pL)\tilde{I}$$

- Lossless line where $R=0$, $G=0$:

$$\begin{array}{ll} \frac{d\tilde{U}}{dx} = -pL\tilde{I} & \frac{d^2\tilde{U}}{dx^2} = p^2LC\tilde{U} \\ \frac{d\tilde{I}}{dx} = -pC\tilde{U} & \frac{d^2\tilde{I}}{dx^2} = p^2LC\tilde{I} \end{array}$$

An infinitesimal section of a homogeneous coaxial transmission line



- Lossless line where $R=0$, $G=0$:

$$\frac{d^2 \tilde{U}}{dx^2} = p^2 LC \tilde{U}$$

$$\frac{d^2 \tilde{I}}{dx^2} = p^2 LC \tilde{I}$$

$$U(x, p) = U_x(p) = \begin{cases} \tilde{U}_+ e^{-p\sqrt{LC}x} \\ \tilde{U}_- e^{p\sqrt{LC}x} \end{cases}$$

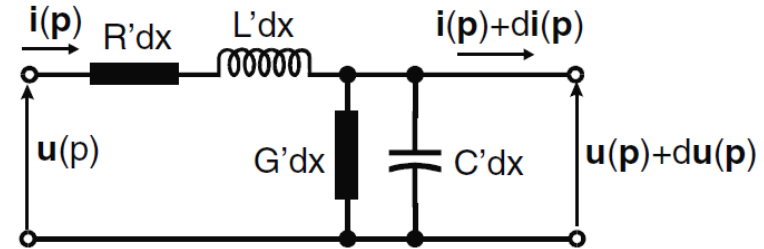

- Inverse Laplace transform: $L\{U_x(t - \tau)\} = \tilde{U} e^{-pt}$

$$U(x, t) = U_x(t) = \begin{cases} U_+(t - x\sqrt{LC}) \\ U_-(t + x\sqrt{LC}) \end{cases}$$

or Linear combination:

$$U_x(t) = U_+(t - x\sqrt{LC}) + U_-(t + x\sqrt{LC})$$

An infinitesimal section of a homogeneous coaxial transmission line



$$U(x, t) = U_x(t) = \begin{cases} U_+(t - x\sqrt{LC}) \\ U_-(t + x\sqrt{LC}) \end{cases}$$

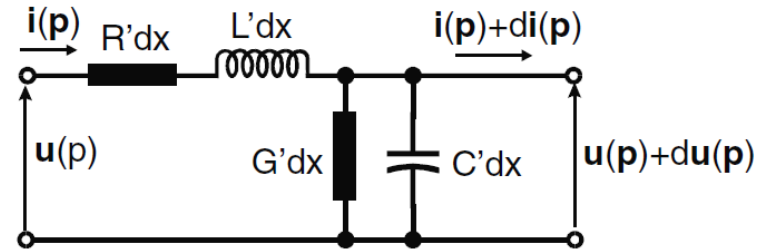

or Linear combination: $U_x(t) = U_+(t - x\sqrt{LC}) + U_-(t + x\sqrt{LC})$

$$\frac{d\tilde{U}}{dx} = -pL\tilde{I} \quad \mp p\sqrt{LC}\tilde{U}_{\pm} = -pL\tilde{I}_{\pm}$$

$$\frac{\tilde{U}_+}{\tilde{I}_+} = -\frac{\tilde{U}_-}{\tilde{I}_-} = \sqrt{\frac{L}{C}} \equiv Z_0$$

$$Z_0 = \frac{U_+(t - x\sqrt{LC})}{I_+(t - x\sqrt{LC})} = -\frac{U_-(t + x\sqrt{LC})}{I_-(t + x\sqrt{LC})}$$

Transmission line

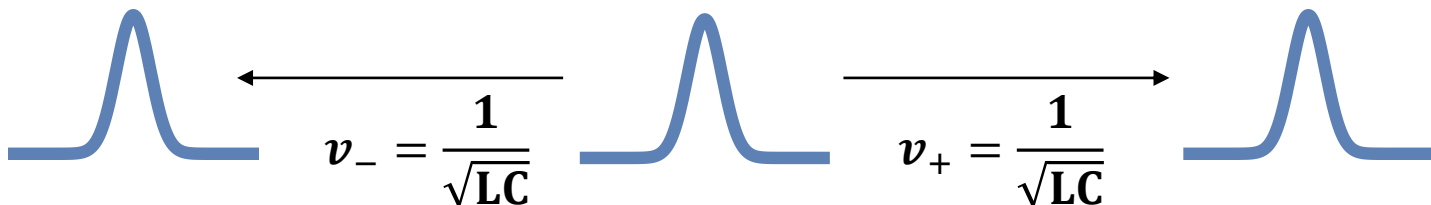

Termination of arbitrary freq-dependent impedance $Z(p)$



- Lossless transmission line terminates with an arbitrary freq-dependent impedance $Z(p)$ in Laplace space.

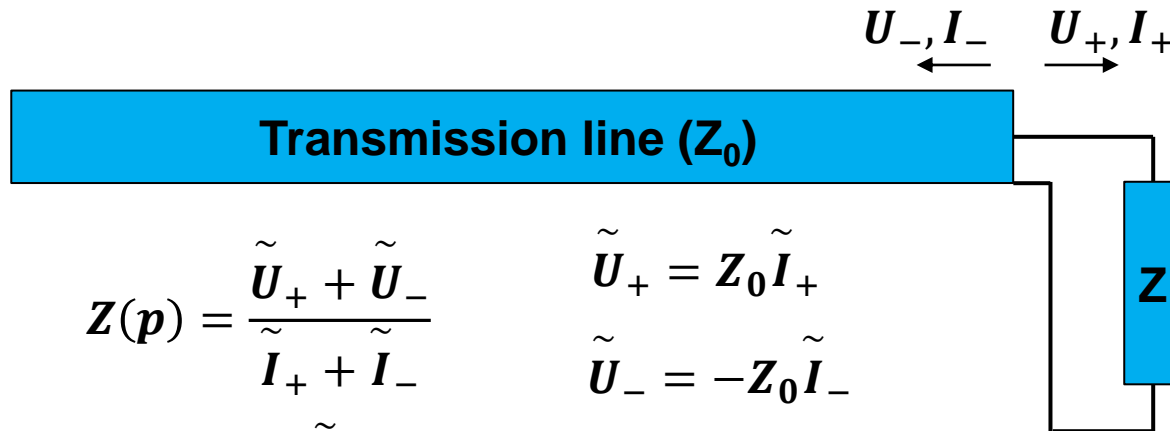

Ohm's law: $Z(p) = \frac{\tilde{U}_+ + \tilde{U}_-}{\tilde{I}_+ + \tilde{I}_-}$ $\tilde{U}_+ = Z_0 \tilde{I}_+$
 $\tilde{U}_- = -Z_0 \tilde{I}_-$

$$Z = \frac{\tilde{U}_+ + \tilde{U}_-}{\frac{\tilde{U}_+}{Z_0} - \frac{\tilde{U}_-}{Z_0}} = Z_0 \frac{1 + \frac{\tilde{U}_-}{\tilde{U}_+}}{1 - \frac{\tilde{U}_-}{\tilde{U}_+}} = Z_0 \frac{1 + \rho}{1 - \rho}$$

$$Z - Z\rho = Z_0 + Z_0\rho$$

Reflection: $\rho \equiv \frac{\tilde{U}_-}{\tilde{U}_+} = \frac{Z - Z_0}{Z + Z_0}$

Termination of arbitrary freq-dependent impedance $Z(p)$

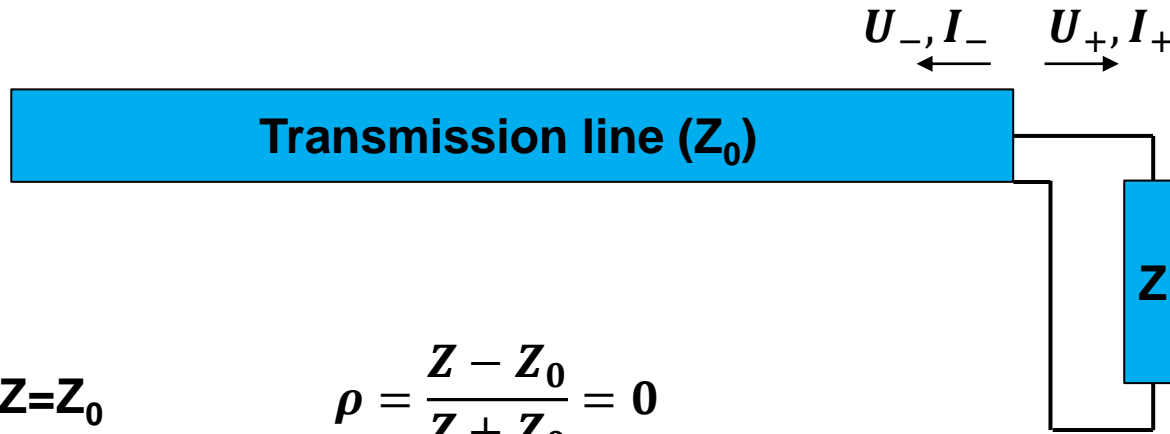

- Match load: $Z=Z_0$
 - No reflection.

$$\rho = \frac{Z - Z_0}{Z + Z_0} = 0$$

- Short-circuit case: $Z=0$
 - Completely reflective with inverted voltage amplitude.

$$\rho = \frac{Z - Z_0}{Z + Z_0} = -1$$

- Open-circuit case: $Z=\infty$
 - Completely reflective with the same polarity.

$$\rho = \frac{Z - Z_0}{Z + Z_0} = 1$$

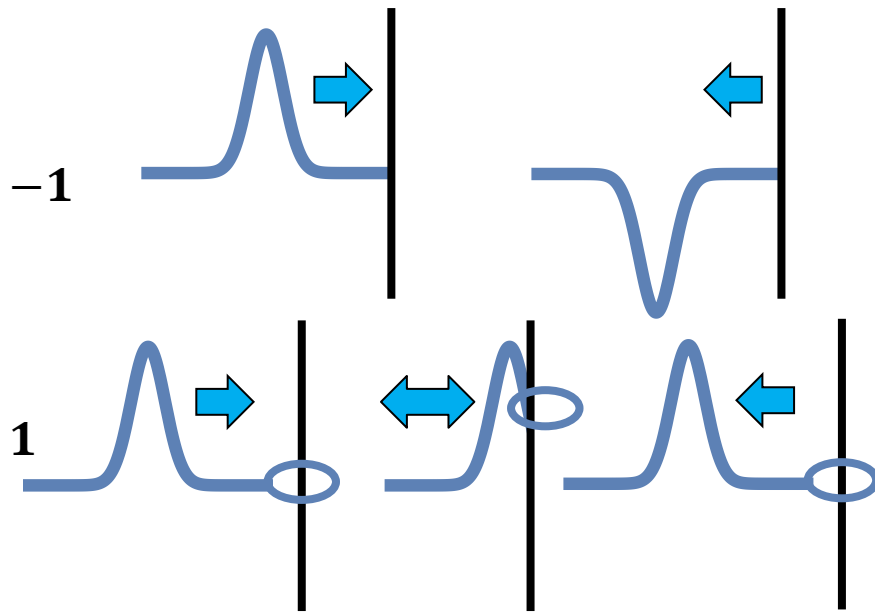

Pulse is reflected when there is an impedance mismatch

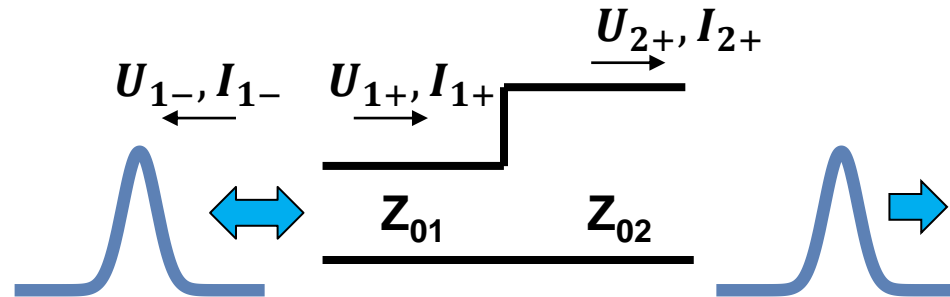

Reflection: $\rho = \frac{U_{1-}}{U_{1+}} = \frac{Z_{02} - Z_{01}}{Z_{02} + Z_{01}}$ $\rho \equiv \frac{\tilde{U}_-}{\tilde{U}_+} = \frac{Z - Z_0}{Z + Z_0}$

$$U_{1+} + U_{1-} = U_{2+}$$

Transmission: $T \equiv \frac{U_{2+}}{U_{1+}} = 1 + \frac{U_{1-}}{U_{1+}} = 1 + \rho$

- For impedance match, i.e., $Z_{01}=Z_{02}$: $\rho = 0$ $T = 1$
 - Reflection-free junction: $Z_{01}=Z_{02}$ is necessary but not sufficient.
- If the geometry of a line changes arbitrary, it becomes impossible to satisfy Maxwell's equation just by superposing the fundamental waves.

Smooth transition is required



- Only by a smooth transition can we achieve the condition that the fields are not disturbed too much so that the reflections can be avoided for high frequency.

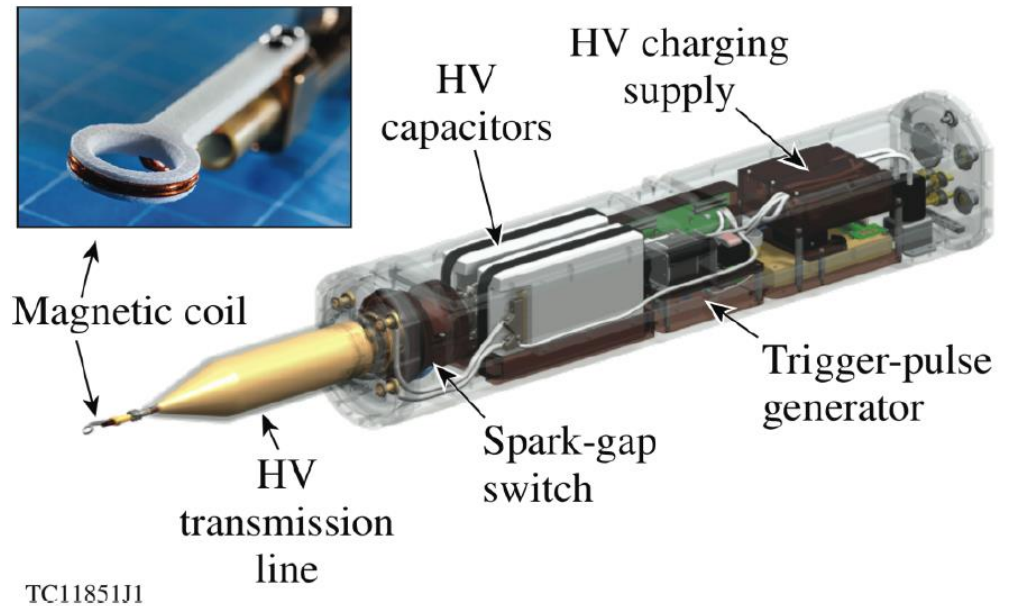
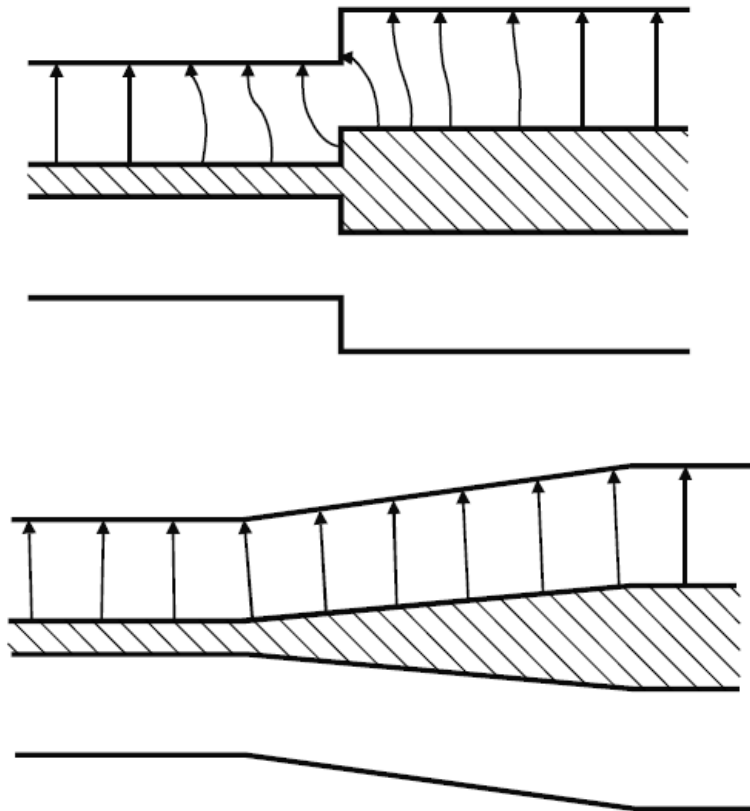

Only half of charged voltage is provided in a basic pulse forming line (PFL)

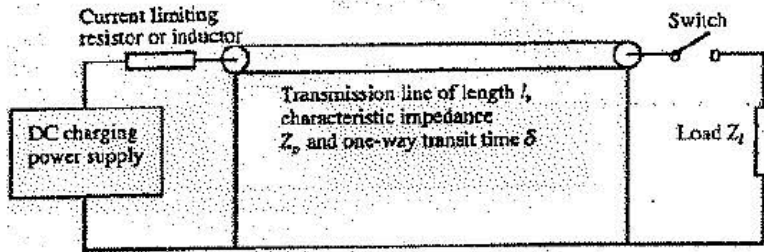

$$t_p = \frac{2l}{v_p} = 2\delta$$

$$V_L = V \frac{Z_L}{Z_0 + Z_L}$$

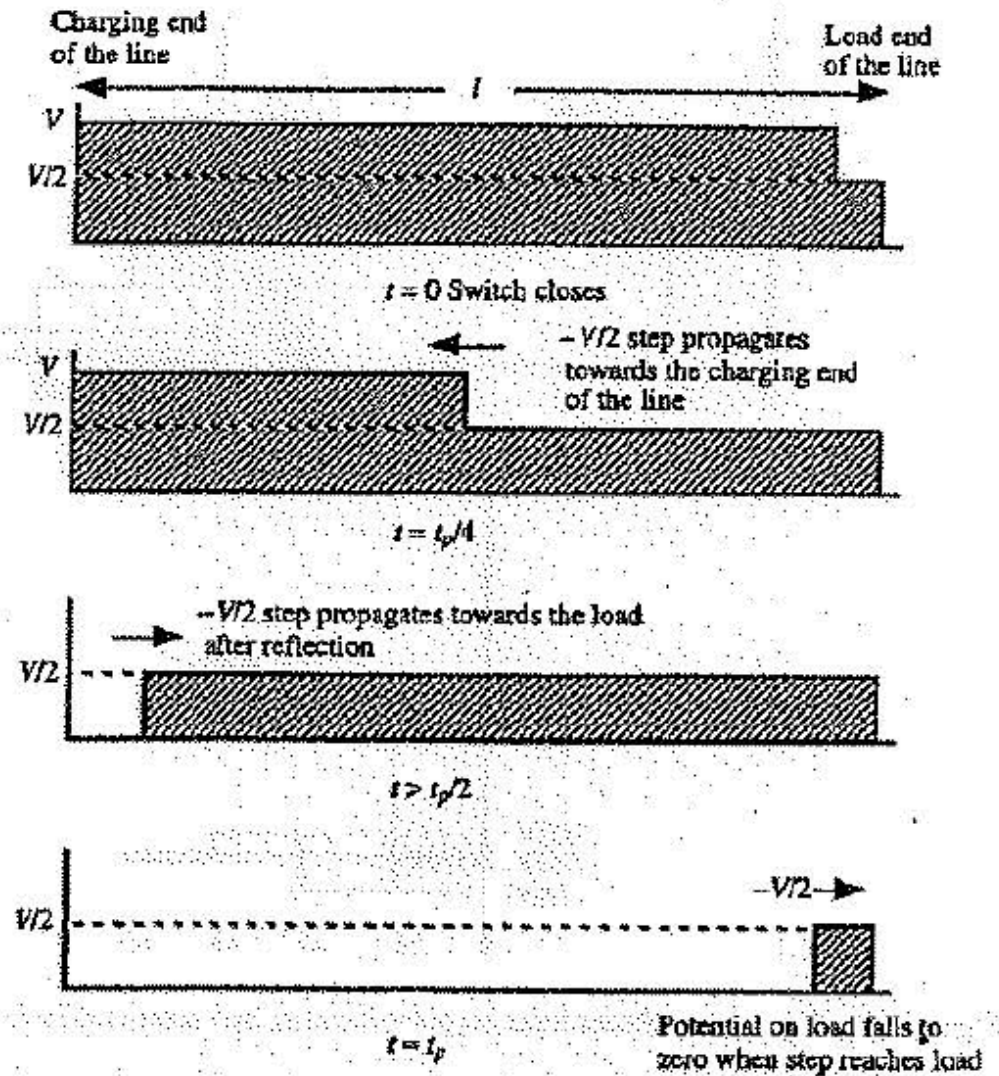

Blumlein pulse forming line (PFL)

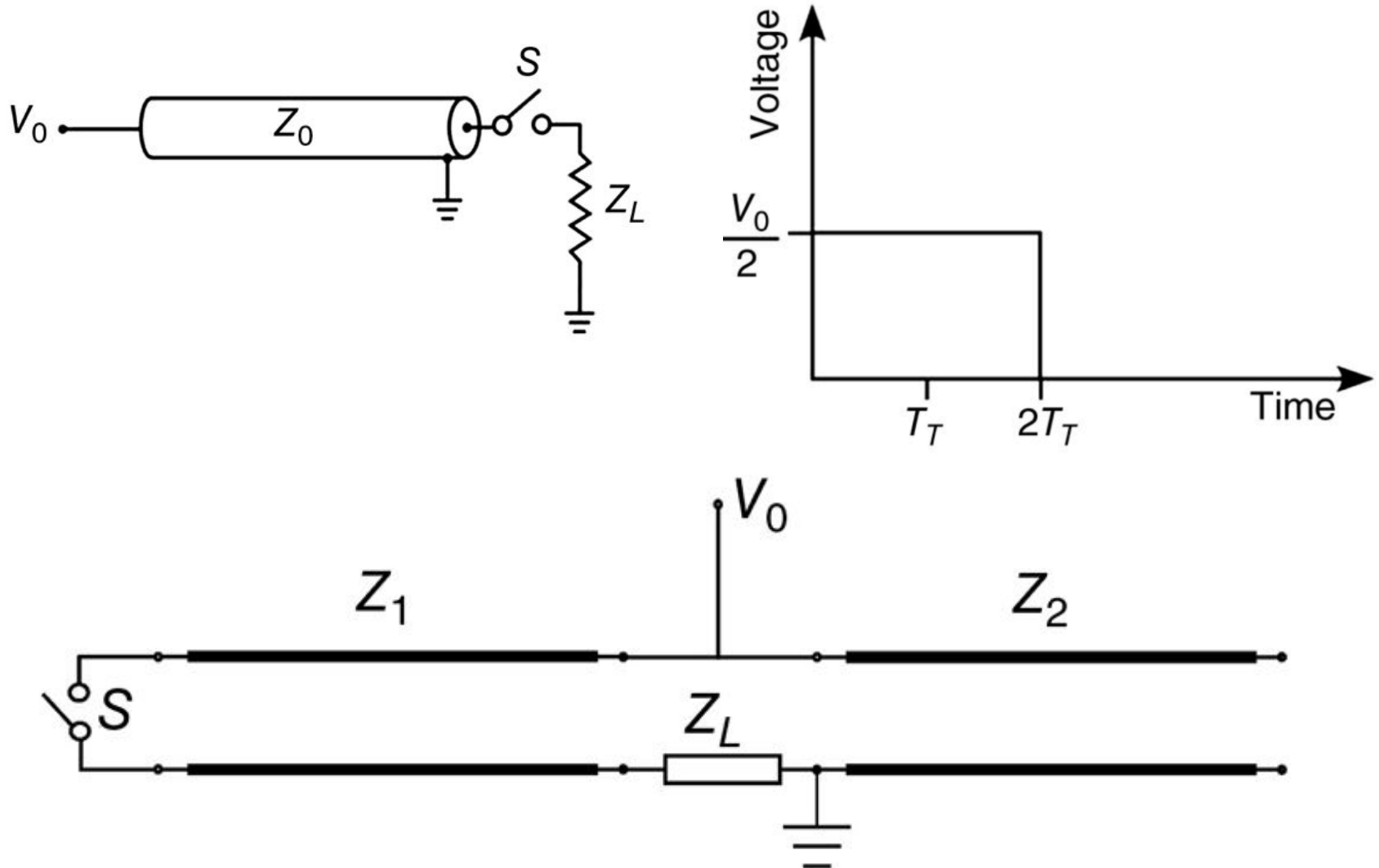

Sequence of Blumlein line

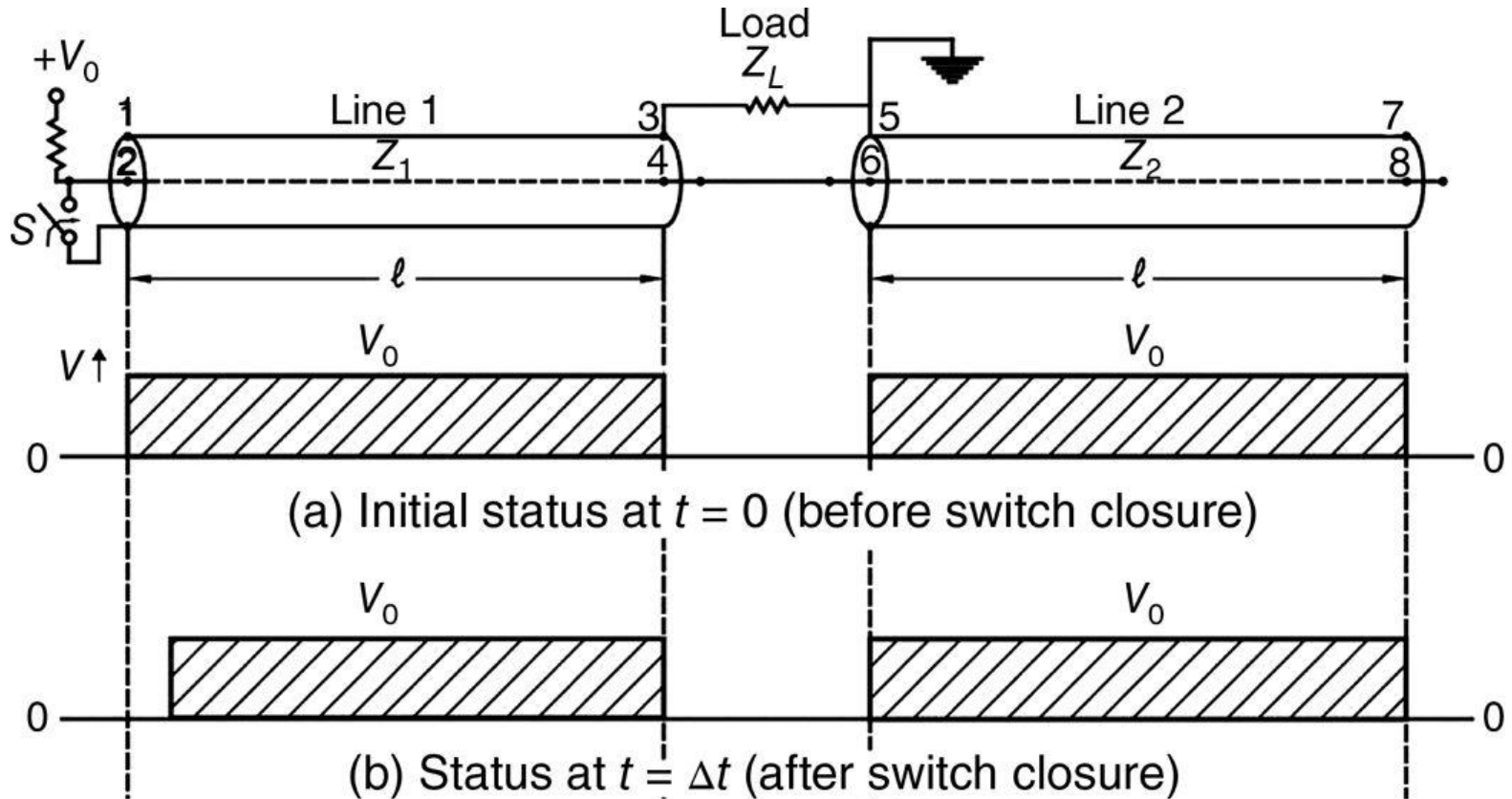

(a)	V_1	V_2	ΔV_{21}	V_3	V_4	ΔV_{43}	V_5	V_6	ΔV_{65}	V_L	V_7	V_8	ΔV_{87}
	0	V_0	V_0	0	V_0	V_0	0	V_0	V_0	0	0	V_0	V_0

Sequence of Blumlein line

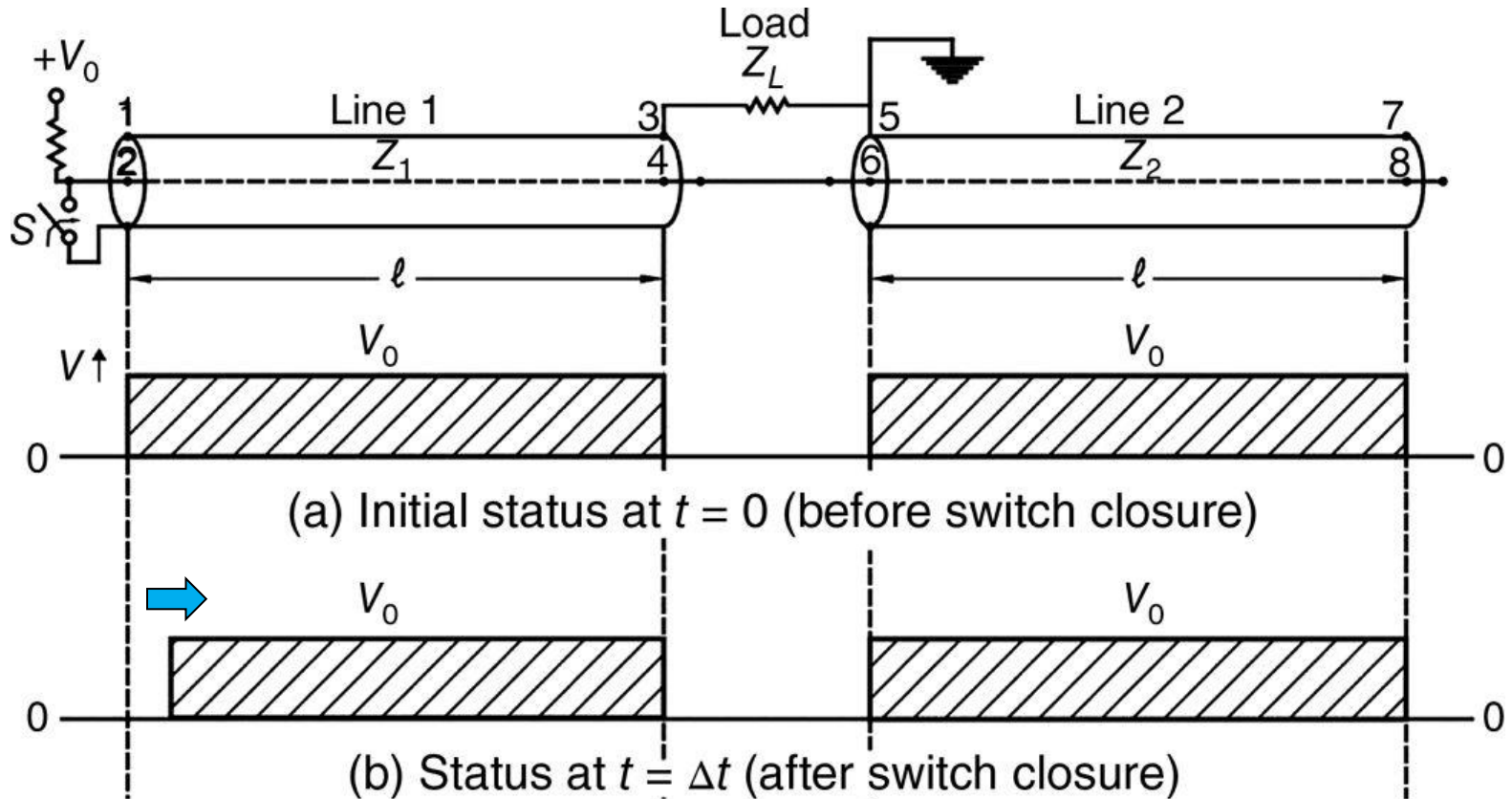

(b)	V_1	V_2	ΔV_{21}	V_3	V_4	ΔV_{43}	V_5	V_6	ΔV_{65}	V_L	V_7	V_8	ΔV_{87}
	0	0	0	0	V_0	V_0	0	V_0	V_0	0	0	V_0	V_0

Sequence of Blumlein line

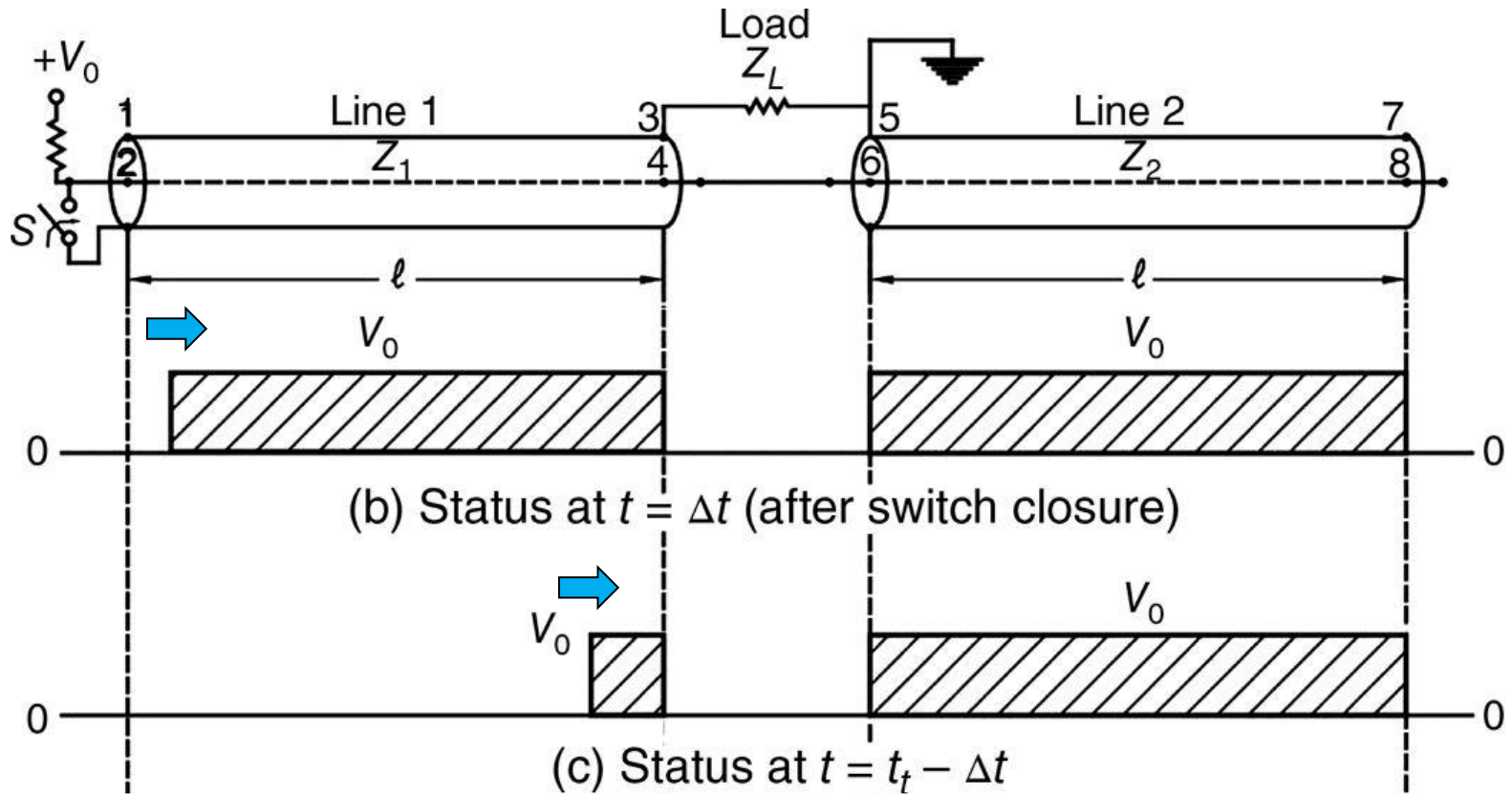

(c)	V_1	V_2	ΔV_{21}	V_3	V_4	ΔV_{43}	V_5	V_6	ΔV_{65}	V_L	V_7	V_8	ΔV_{87}
	0	0	0	0	V_0	V_0	0	V_0	V_0	0	0	V_0	V_0

Sequence of Blumlein line

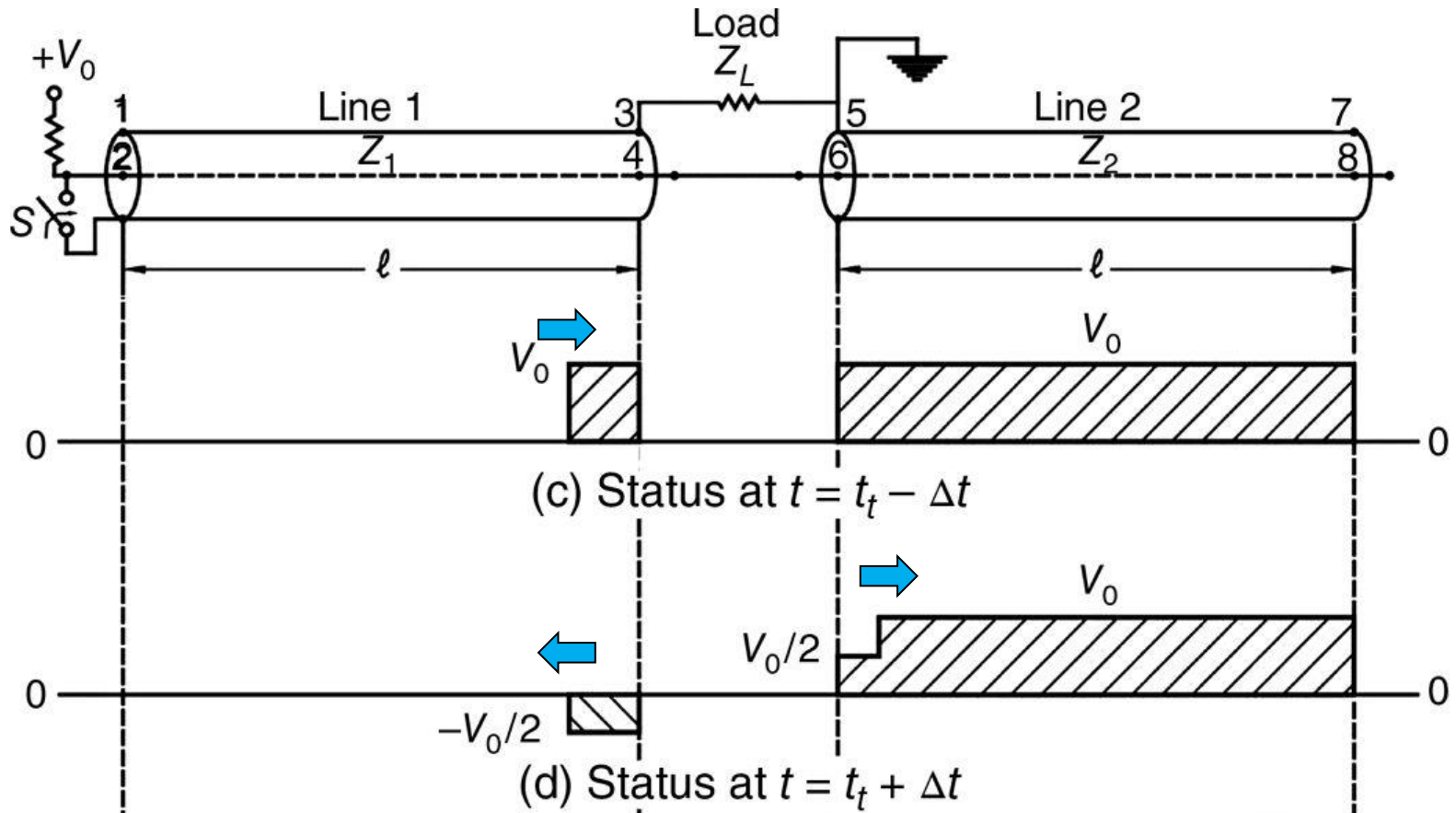

(d)	V_1	V_2	ΔV_{21}	V_3	V_4	ΔV_{43}	V_5	V_6	ΔV_{65}	V_L	V_7	V_8	ΔV_{87}
	0	0	0	V_0	$V_0/2$	$-V_0/2$	0	$V_0/2$	$V_0/2$	V_0	0	V_0	V_0

Sequence of Blumlein line

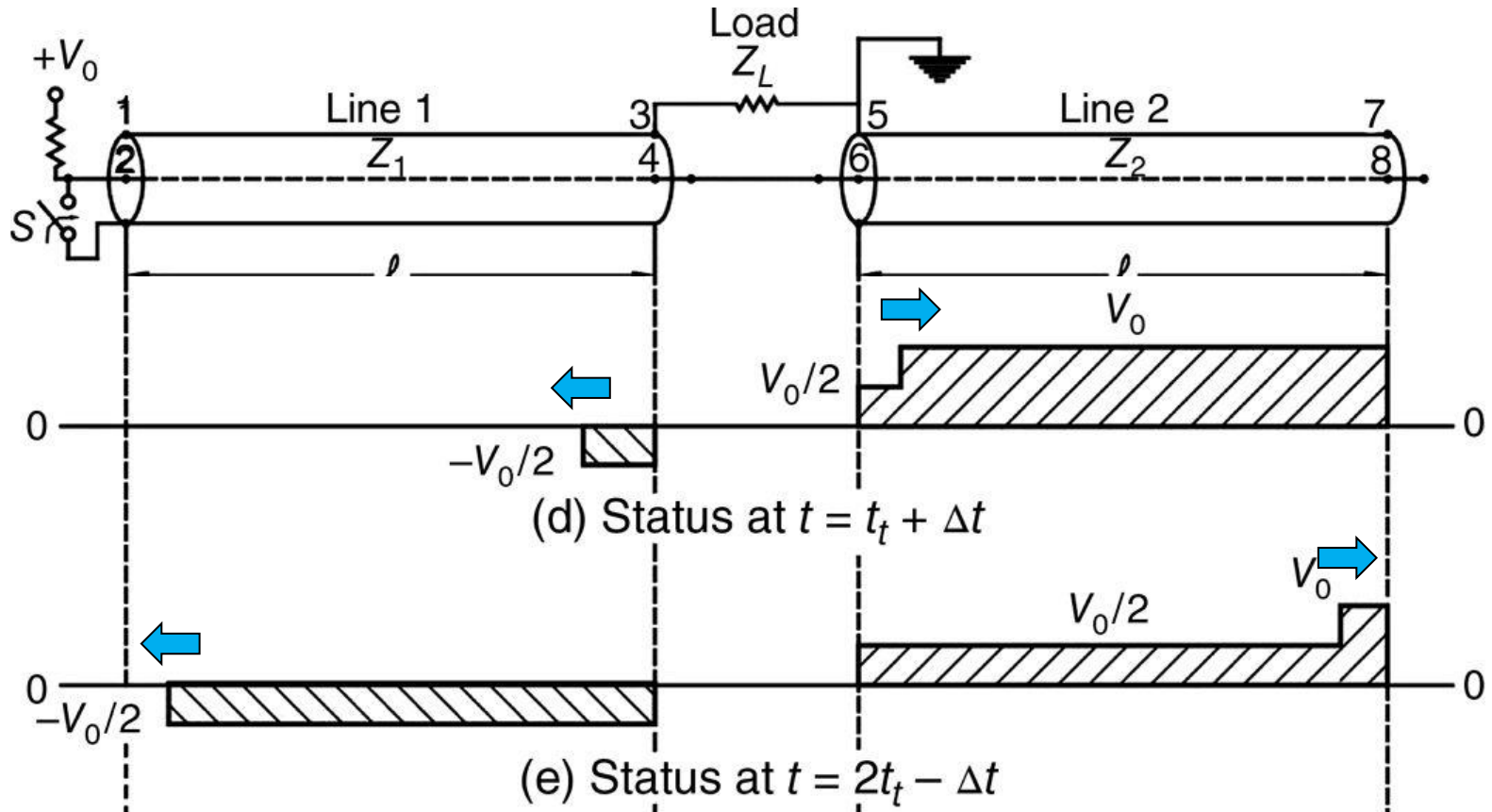

(e)	V_1	V_2	ΔV_{21}	V_3	V_4	ΔV_{43}	V_5	V_6	ΔV_{65}	V_L	V_7	V_8	ΔV_{87}
	0	0	0	V_0	$V_0/2$	$-V_0/2$	0	$V_0/2$	$V_0/2$	V_0	0	V_0	V_0

Sequence of Blumlein line

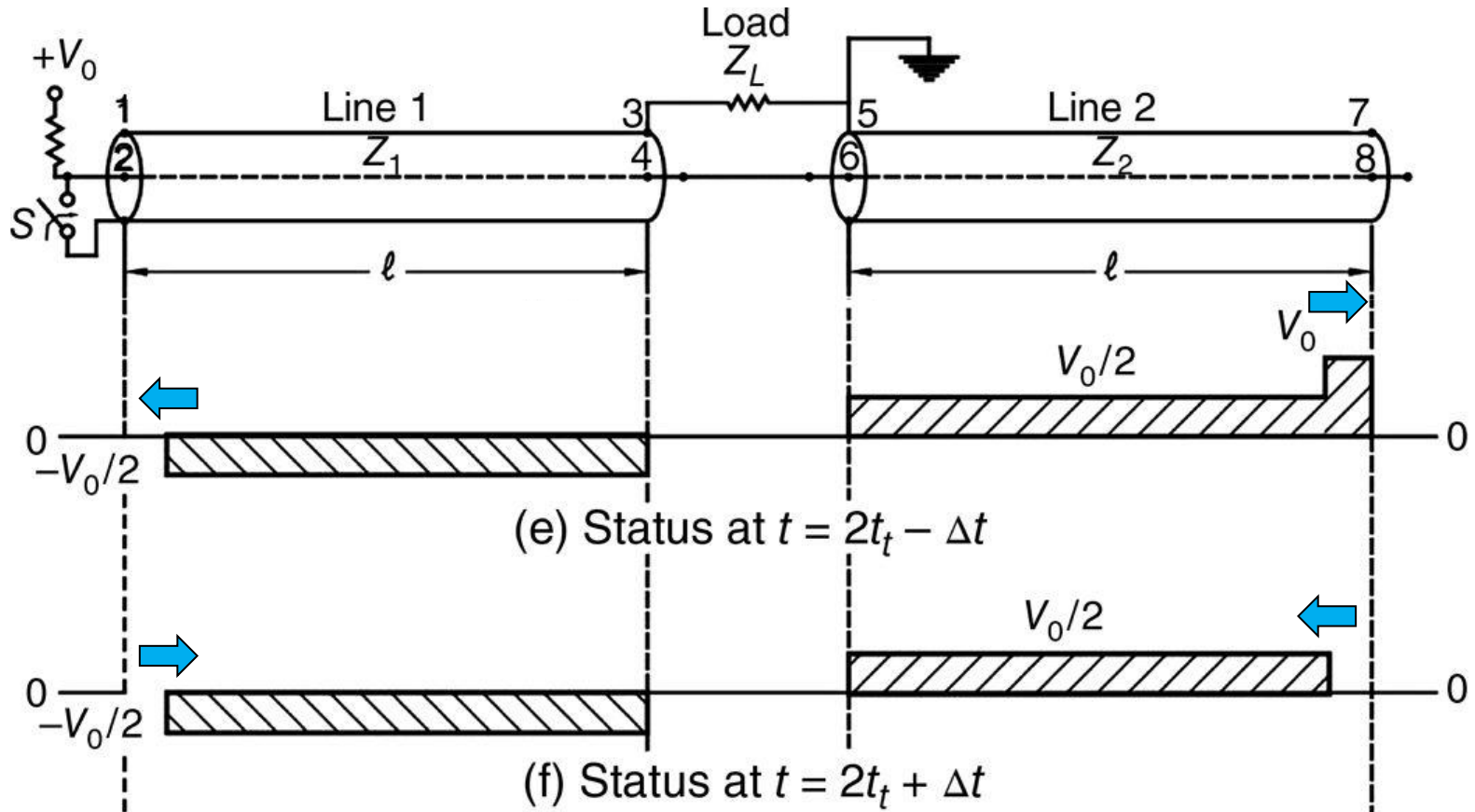

(f)	V_1	V_2	ΔV_{21}	V_3	V_4	ΔV_{43}	V_5	V_6	ΔV_{65}	V_L	V_7	V_8	ΔV_{87}
	0	0	0	V_0	$V_0/2$	$-V_0/2$	0	$V_0/2$	$V_0/2$	V_0	0	0	0

Sequence of Blumlein line

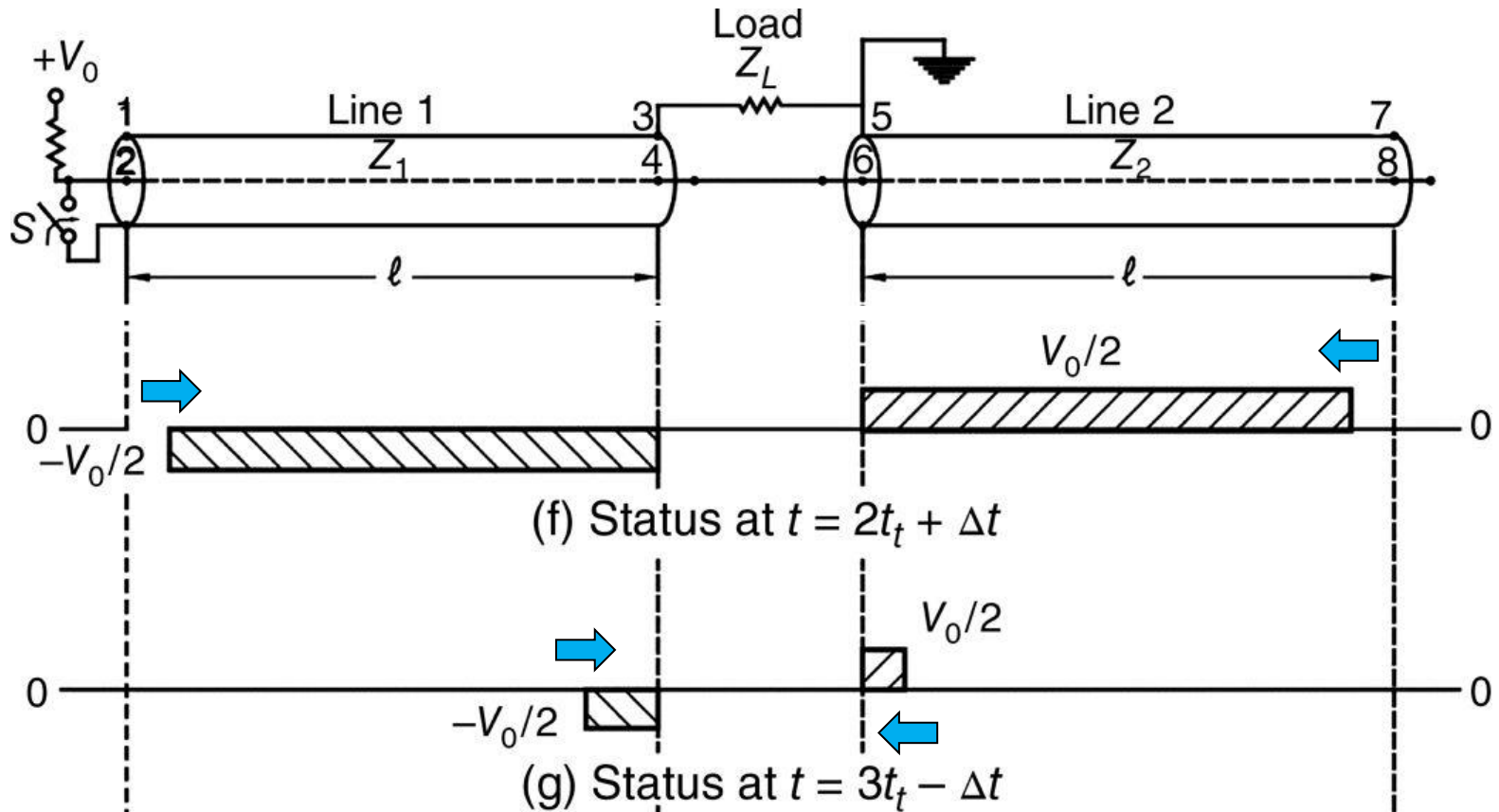

(g)	V_1	V_2	ΔV_{21}	V_3	V_4	ΔV_{43}	V_5	V_6	ΔV_{65}	V_L	V_7	V_8	ΔV_{87}
	0	0	0	V_0	$V_0/2$	$-V_0/2$	0	$V_0/2$	$V_0/2$	V_0	0	0	0

Sequence of Blumlein line

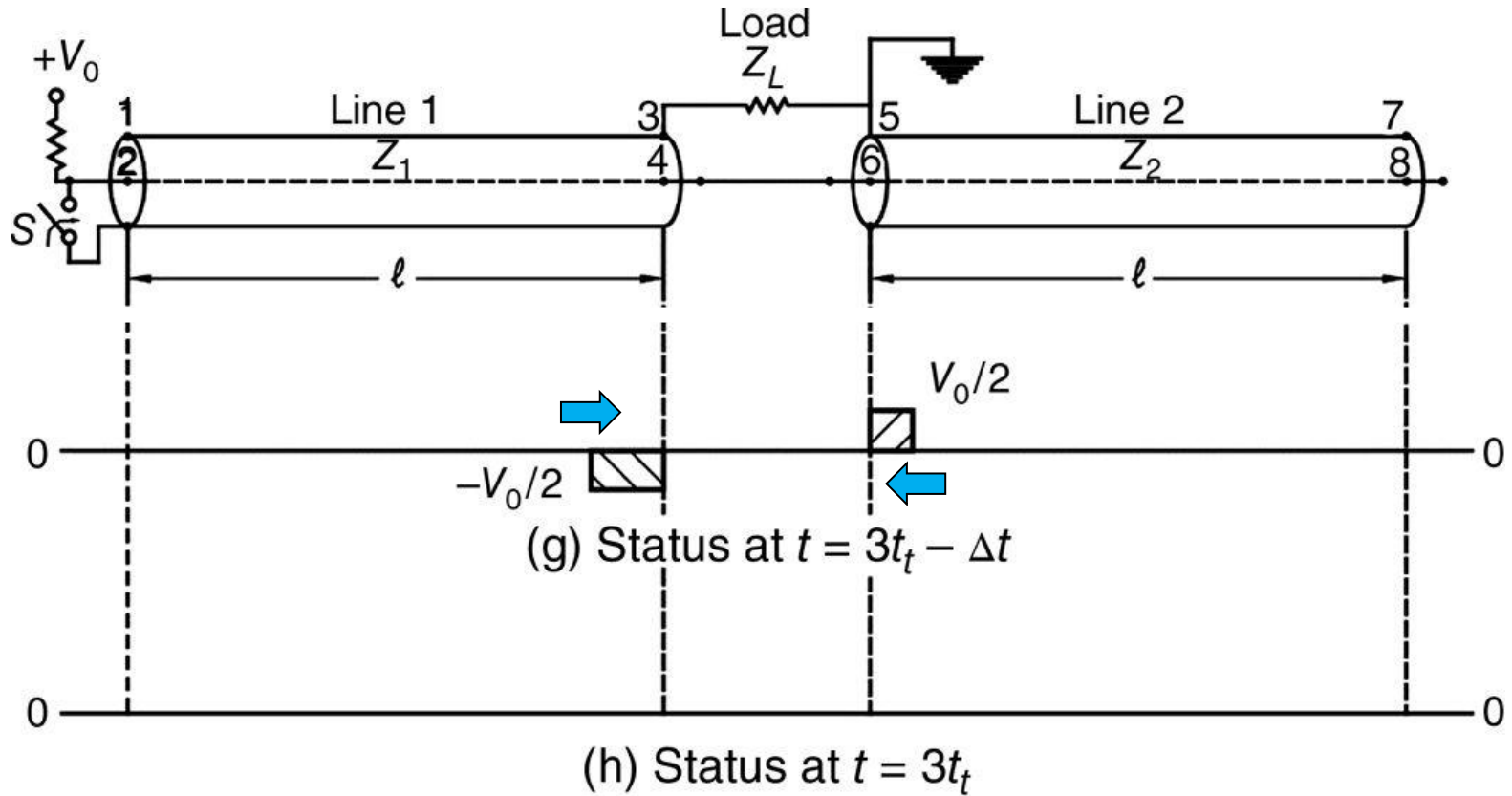

(h)	V_1	V_2	ΔV_{21}	V_3	V_4	ΔV_{43}	V_5	V_6	ΔV_{65}	V_L	V_7	V_8	ΔV_{87}
	0	0	0	0	0	0	0	0	0	0	0	0	0

A Blumlein line can be built by using two coaxial transmission line

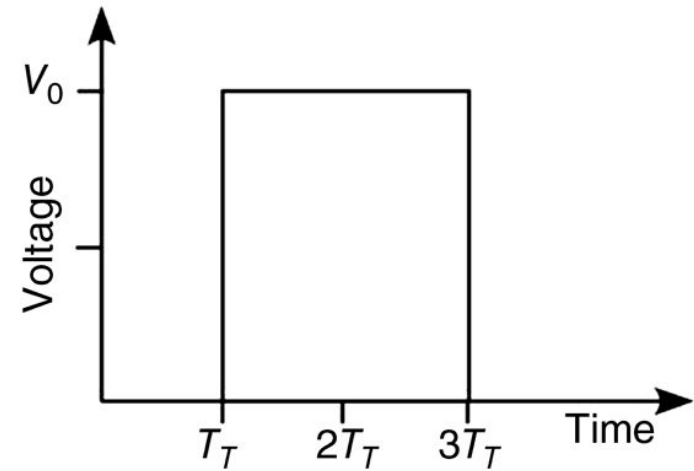
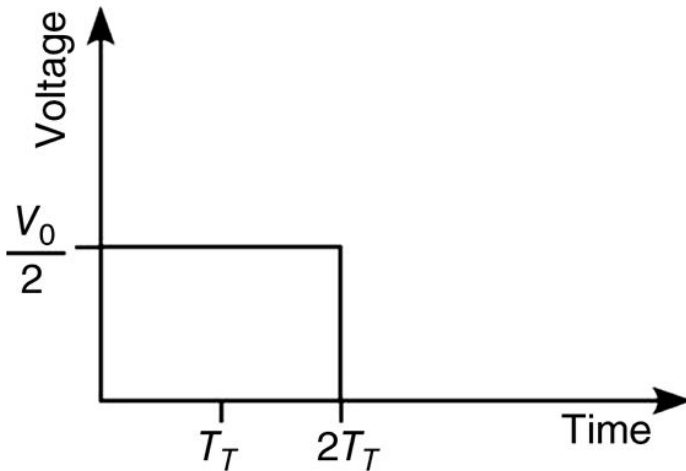
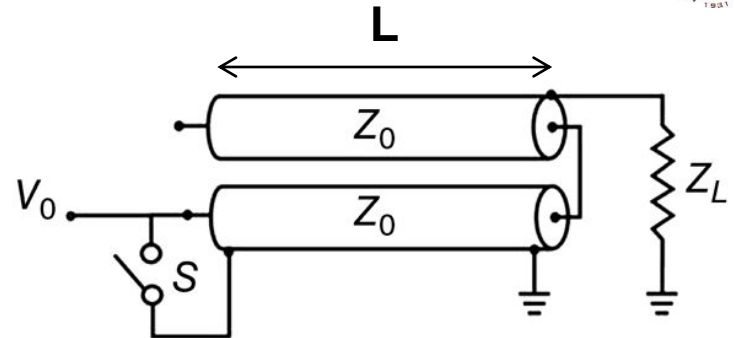
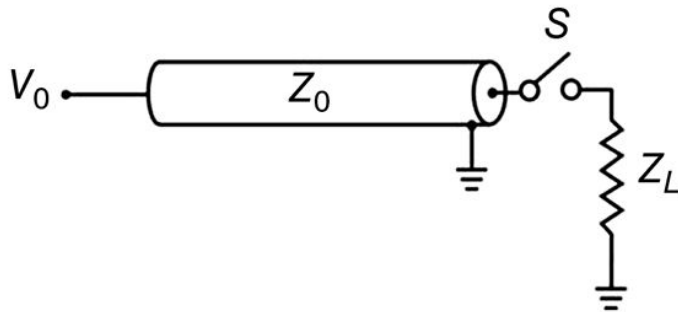

- Example: RG58 coaxial cable, 50Ω , $V_{\text{signal}} \sim 2 \times 10^{10} \text{ cm/s}$
 $\Rightarrow L=10 \text{ cm}$, $\Delta t=1 \text{ ns}$.

Coaxial Blumlein line

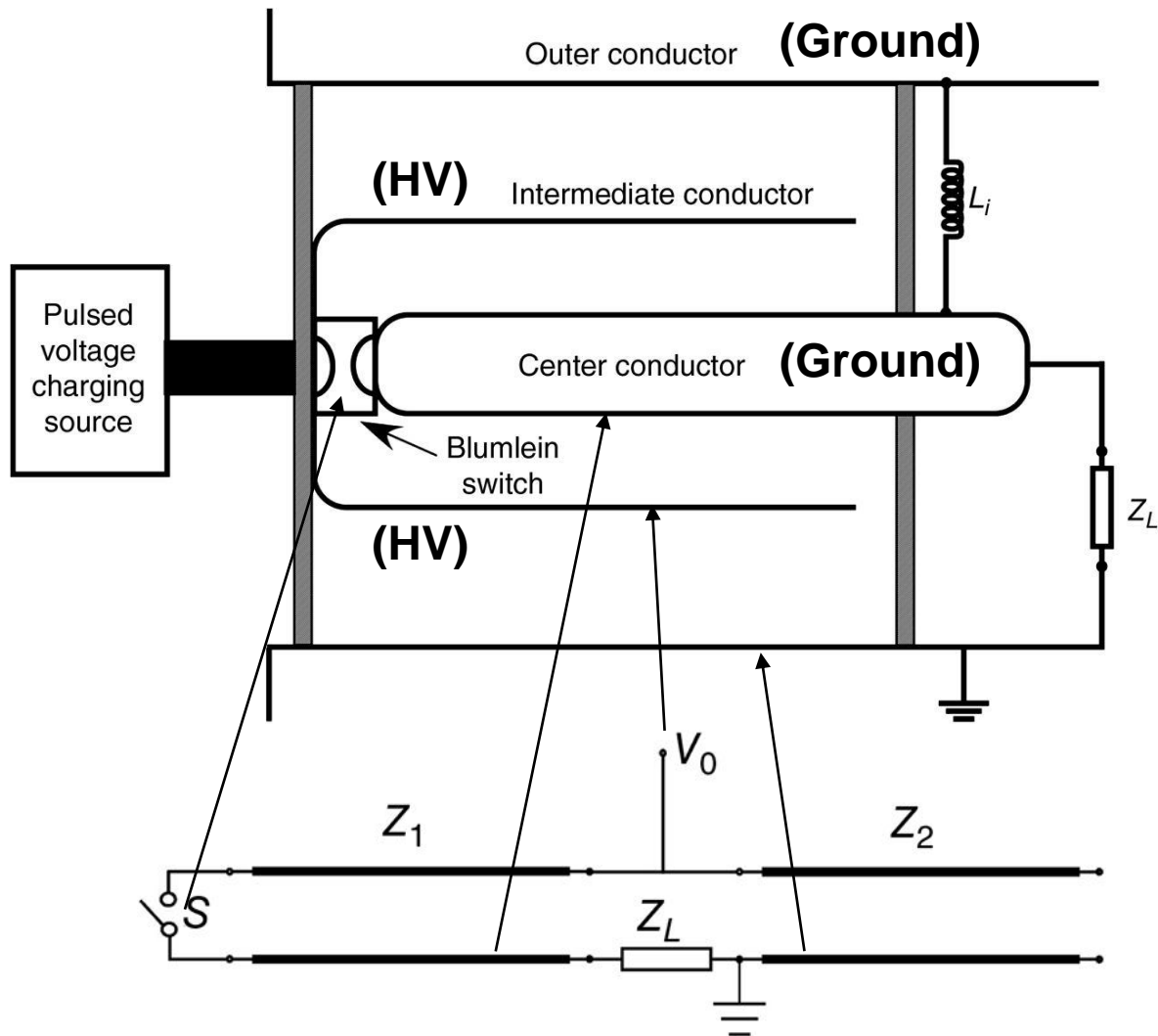

Outlines



- Switches
 - Closing switches: the switching process is associated with voltage breakdown across an initially insulant element.
 - Opening switches: the switching process is associated with a sudden growth of its impedance.
- **Pulse-forming lines**
 - Blumlein line
 - **Pulse-forming network**
 - Pulse compressor
- Pulse transmission and transformation

A simple pulsed-power system is a RLC circuit



- Before discharge

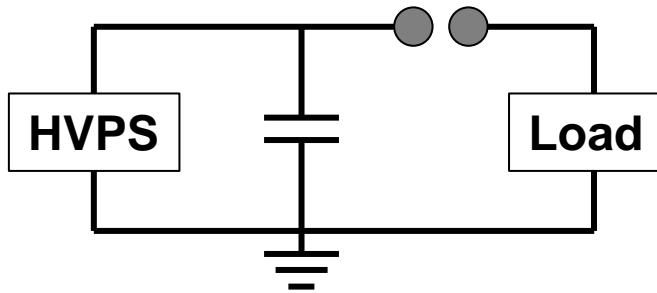

- After discharge

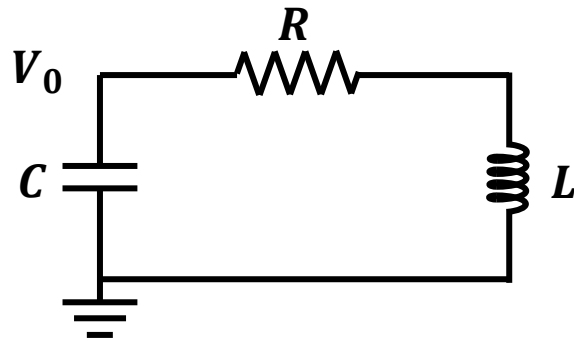
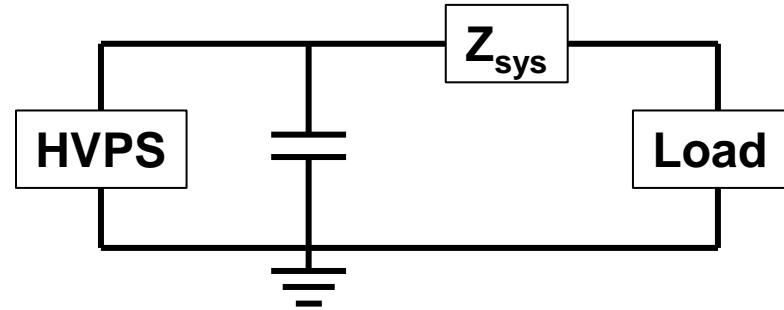

- How can we generate a square current pulse?

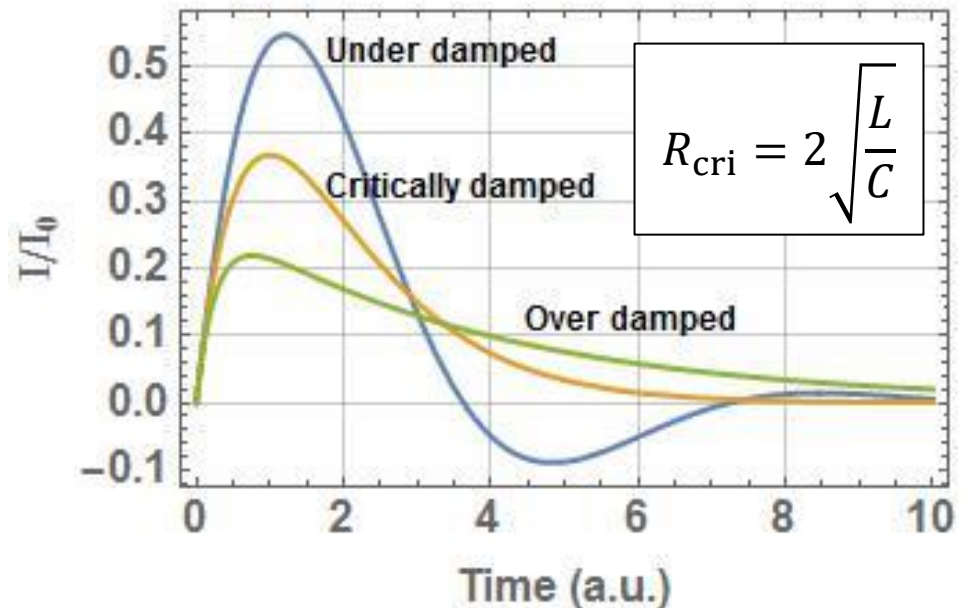

Pulse-forming network (PFN)

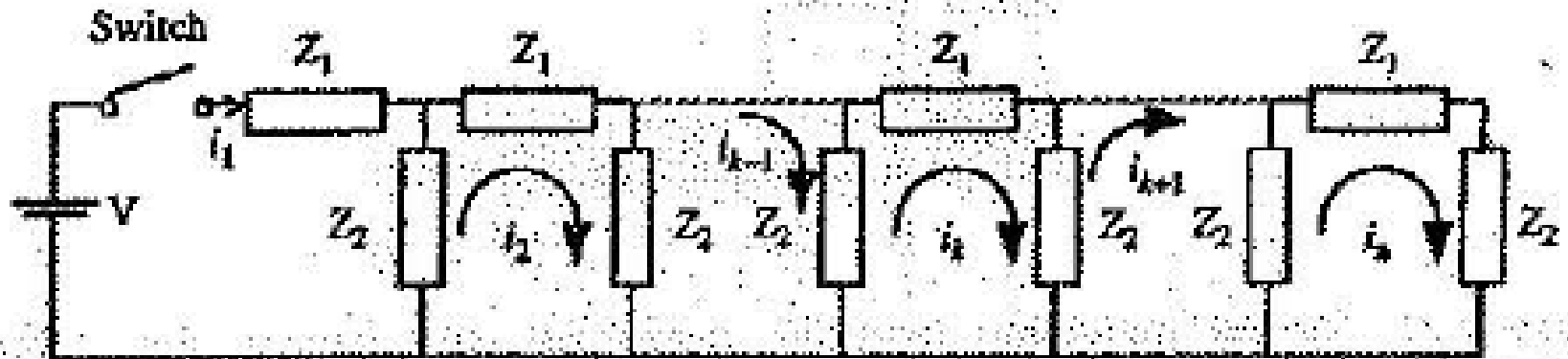
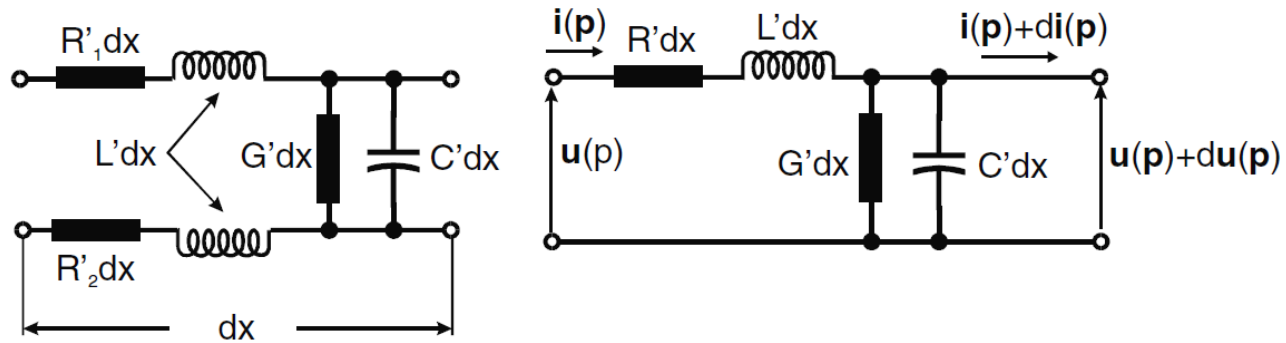
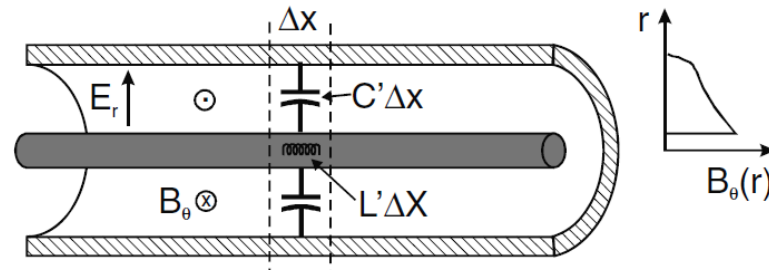

Equivalent Guillemin Networks

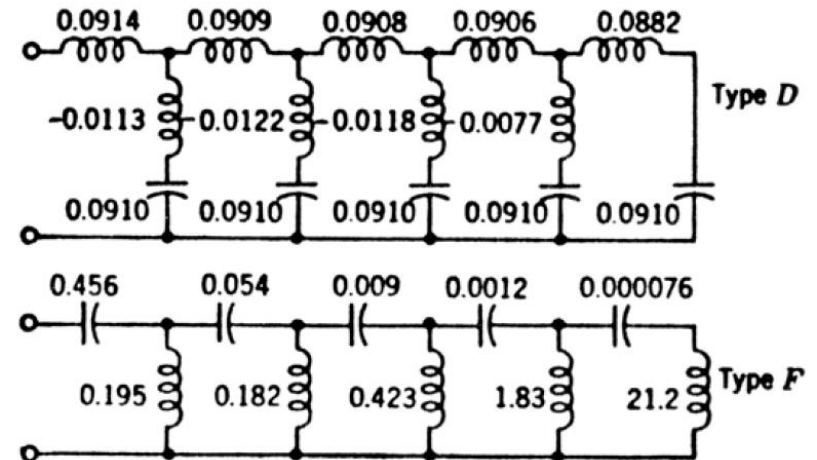
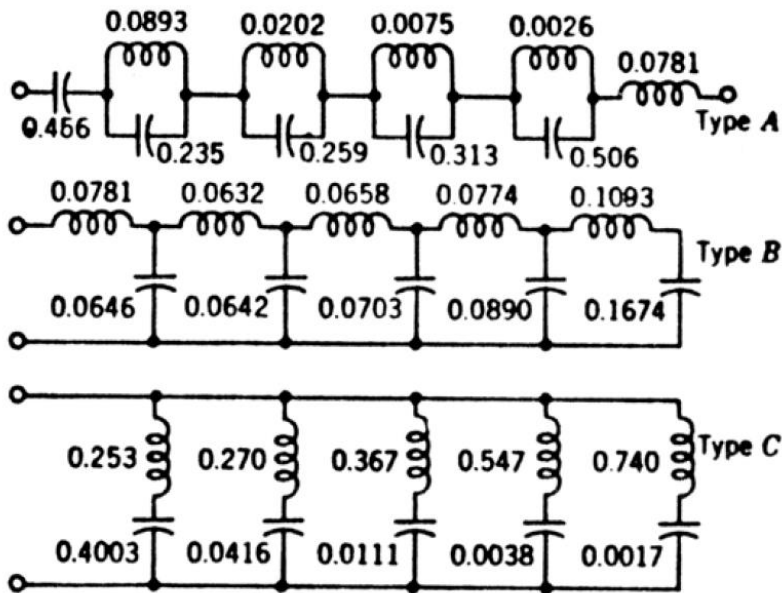

Pulse-forming LC chain

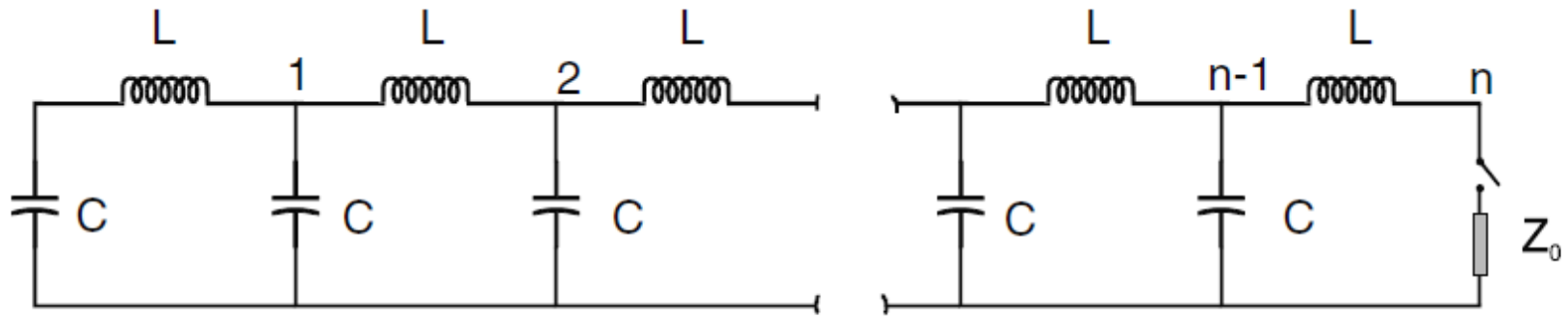
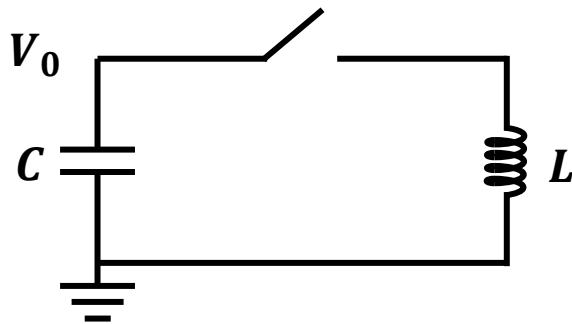

Fig. 5.11. Pulse-forming LC chain

The current output of a LC circuit is a basis of Fourier series



$$I(t) = V_0 \sqrt{\frac{C}{L}} \sin\left(\frac{t}{\sqrt{LC}}\right)$$

$$V(t) = V_0 \cos\left(\frac{t}{\sqrt{LC}}\right)$$

$$Z = \sqrt{\frac{L}{C}} \quad \omega = \frac{1}{\sqrt{LC}}$$

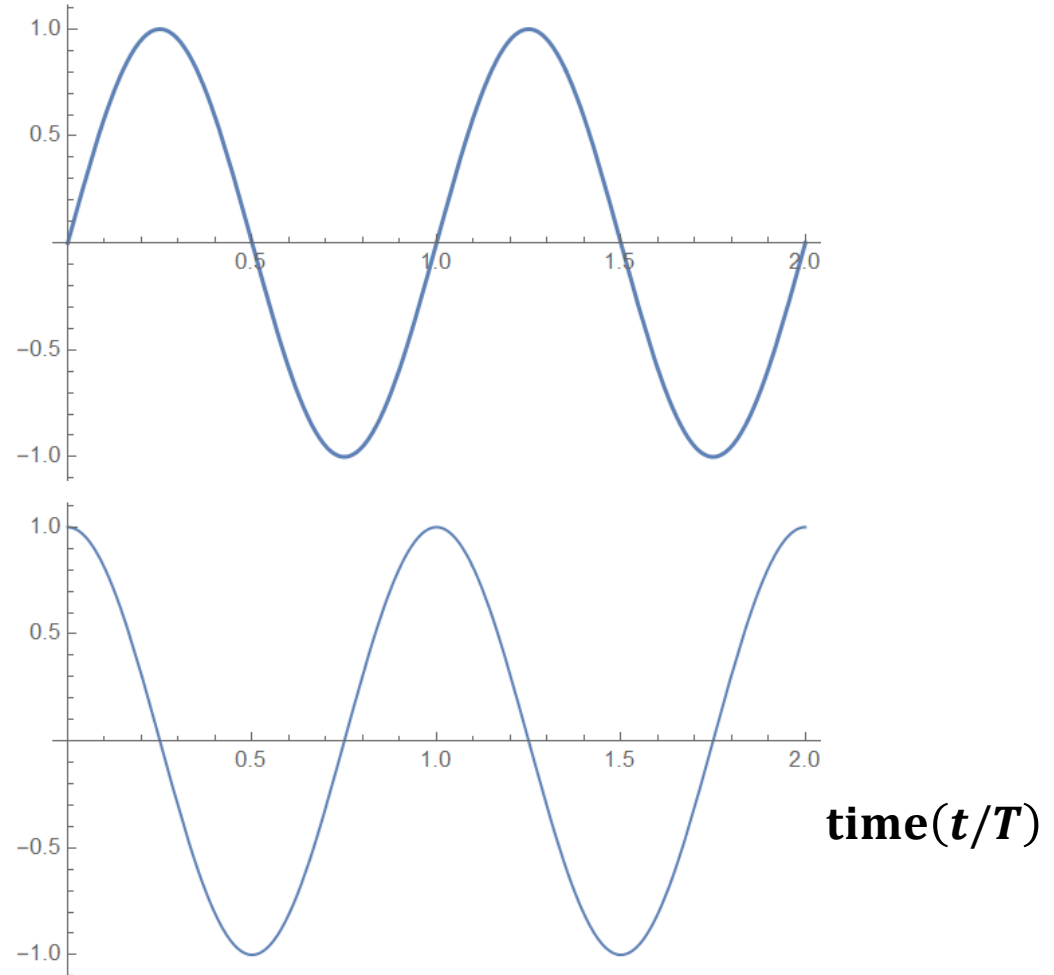

A trapezoidal wave can be expressed by Fourier series (Guillemin's method)

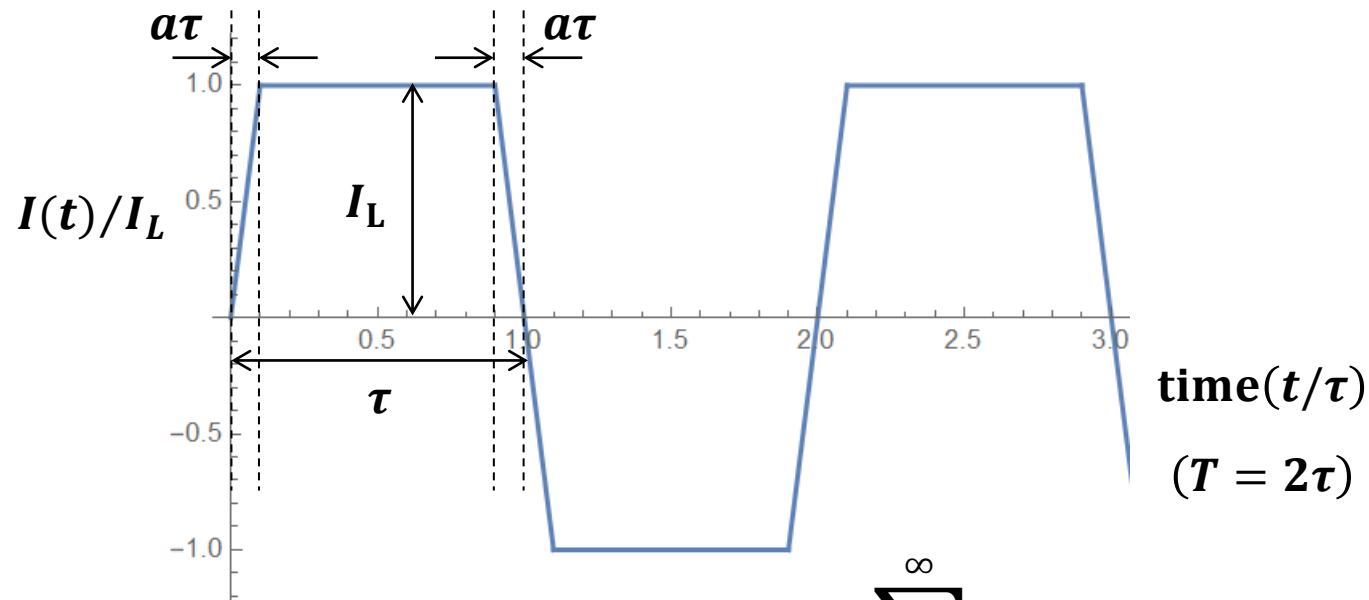

$$\frac{i(t)}{I_L} = \frac{t}{a\tau}, \quad 0 \leq t \leq a\tau$$

$$\frac{i(t)}{I_L} = 1, \quad a\tau \leq t \leq \tau - a\tau$$

$$\frac{i(t)}{I_L} = \frac{\tau - t}{a\tau}, \quad \tau - a\tau \leq t \leq \tau$$

$$i(t) = I_L \sum_{n=1}^{\infty} b_n \sin\left(\frac{n\pi t}{\tau}\right)$$

$$\text{where } b_n = \frac{2}{\tau} \int_0^{\tau} \frac{i(t)}{I_L} \sin\left(\frac{n\pi t}{\tau}\right) dt$$

$$b_n = \frac{4}{n\pi} \frac{\sin(n\pi a)}{n\pi a}, \text{ where } n = 1, 3, 5, \dots$$

The required inductance and capacitance are obtained by comparing LC output with the Fourier series

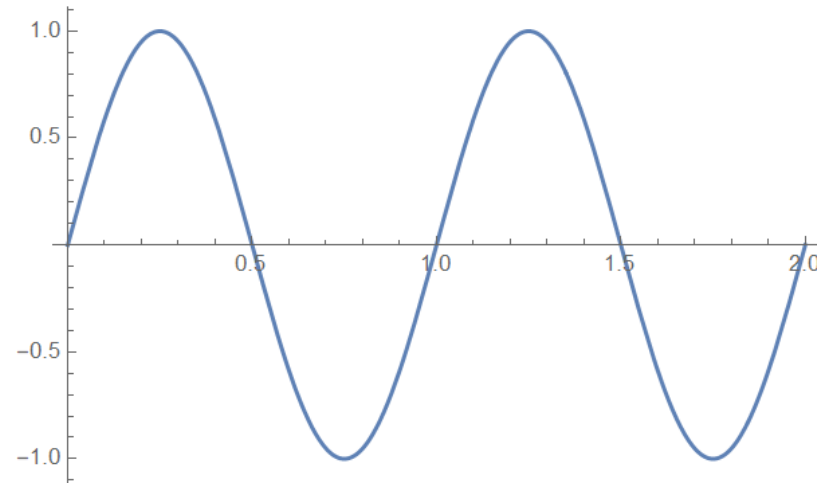
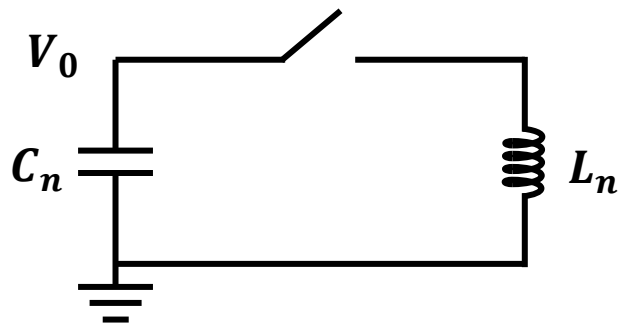

$$I_n(t) = V_0 \sqrt{\frac{C_n}{L_n}} \sin\left(\frac{t}{\sqrt{L_n C_n}}\right)$$

$$i(t) = I_L \sum_{n=1}^{\infty} b_n \sin\left(\frac{n\pi t}{\tau}\right)$$

$$b_n = \frac{4}{n\pi} \frac{\sin(n\pi a)}{n\pi a}, \text{ where } n = 1, 3, 5, \dots$$

$$L_n = \frac{Z_n \tau}{n\pi b_n} = \frac{V}{I_L} \frac{\tau}{n\pi b_n}$$

$$C_n = \frac{\tau b_n}{n\pi Z_n} = \frac{I_L}{V} \frac{\tau b_n}{n\pi}$$

$$Z_n = \frac{V}{I_L}$$

A trapezoidal current output can be generated using Guillemin's pulse-forming networks

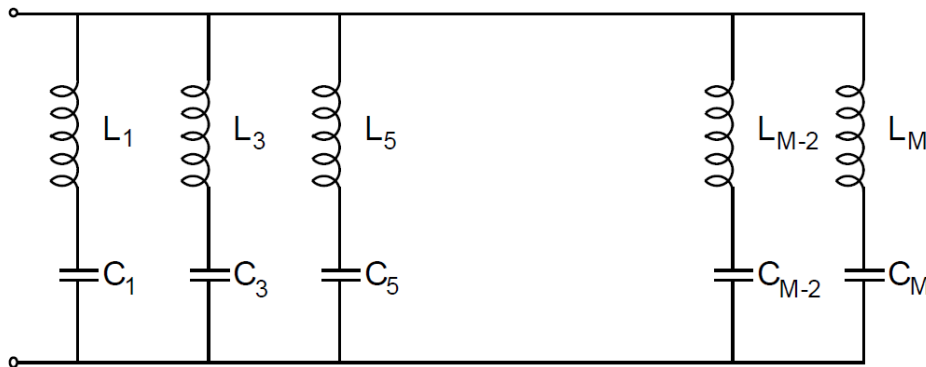
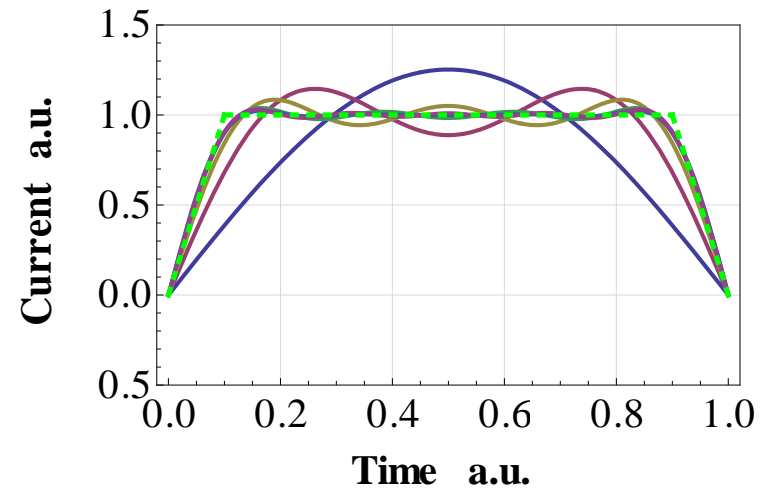
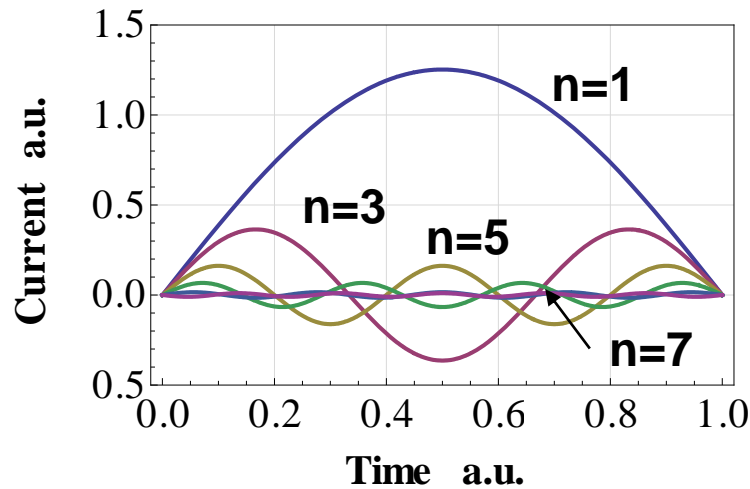

$$I(t) = I_L \sum b_n \sin\left(\frac{n\pi t}{\tau}\right)$$

$$b_n = \frac{4}{n\pi} \frac{\sin(n\pi a)}{n\pi a}$$

$$L_n = \frac{Z\tau}{n\pi b_n} \quad C_n = \frac{\tau b_n}{n\pi Z} \quad Z = \frac{V}{I_L}$$

Fourier components of $\tau=1$ ms, $a=0.1$

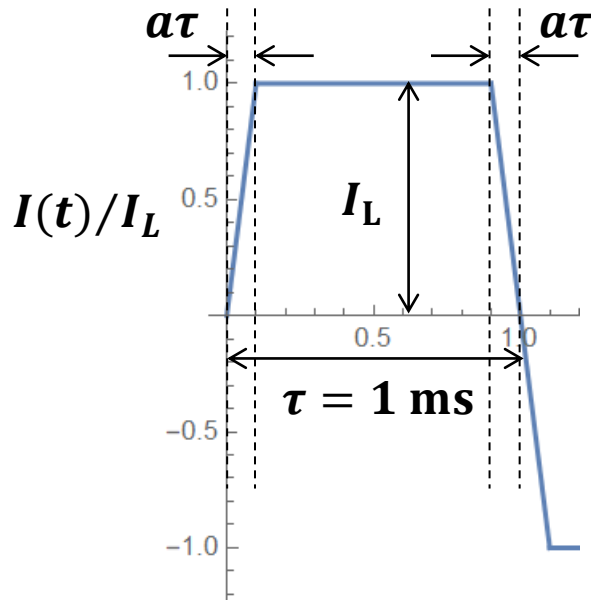

$\text{time}(t/\tau)$
($T = 2\tau$)

$$i(t) = I_L \sum_{n=1}^{\infty} b_n \sin\left(\frac{n\pi t}{\tau}\right)$$

$$b_n = \frac{4}{n\pi} \frac{\sin(n\pi a)}{n\pi a}, \text{ where } n = 1, 3, 5, \dots$$

n	#/
b1	1.2524
b3	0.3643
b5	0.1621
b7	0.069
b9	0.0155

Coils with 8 turns and a PFN charged to 1 kV will be used



I (kA)	V (kV)		1	2	3	4	5	E (kJ)	% to 100 J
20	2	L(uH)	25.4	26.1	39.3	68.0	228.7	9.0	1.1 %
		C(uF)	3986.5	386.5	103.2	30.4	5.5		
20	1	L(uH)	12.7	14.6	19.6	34.0	114.4	4.5	2.2 %
		C(uF)	7973.0	773.1	206.4	60.9	10.9		
2.5	2	L(uH)	203.3	233.0	314.2	543.7	1830.0	1.1	8.9 %
		C(uF)	498.3	48.3	12.9	3.8	0.7		
2.5	1	L(uH)	101.7	116.5	157.1	271.8	915.0	0.6	17.7 %
		C(uF)	996.6	96.6	25.8	7.6	1.4		

A square pulse with a flat top of 2.5 kA can be generated

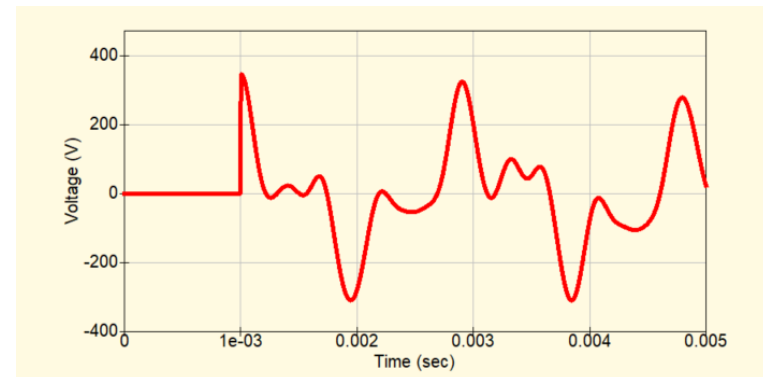
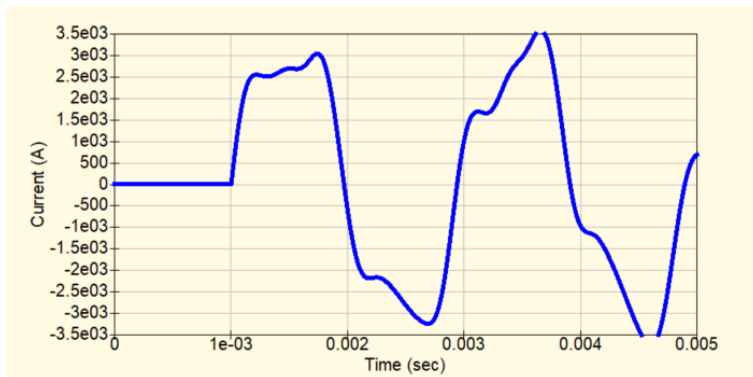
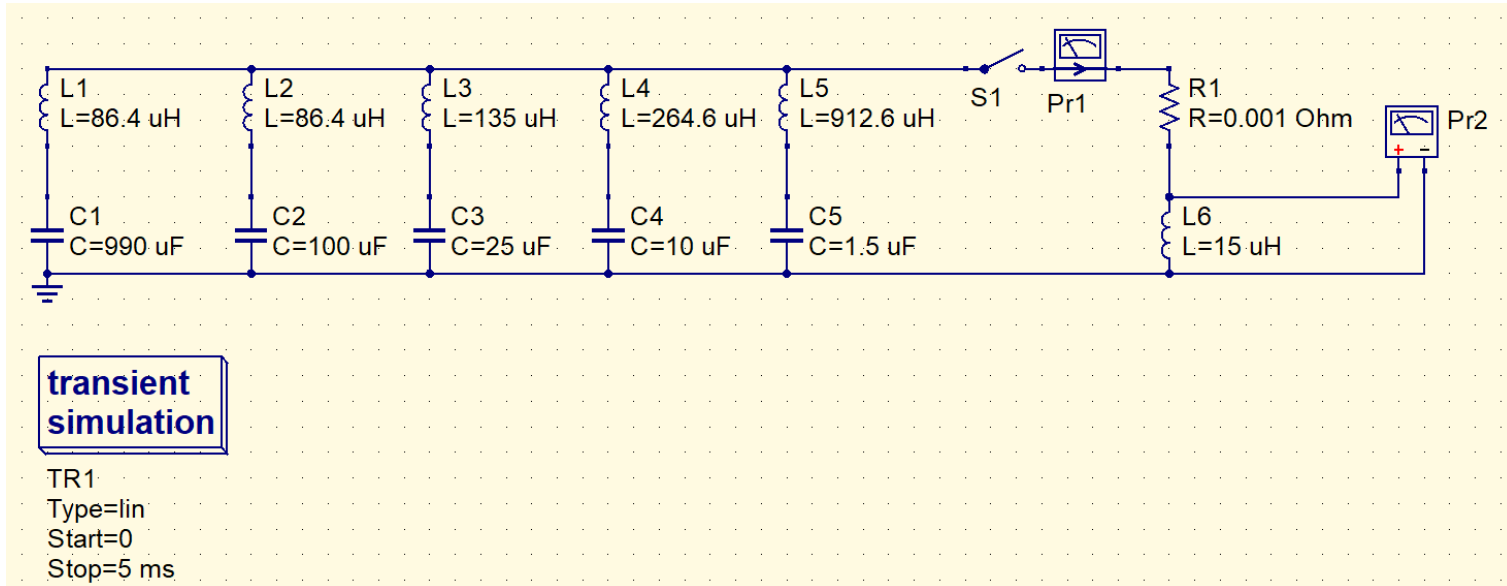

A simple PFN with constant C and L in all stages can also be used

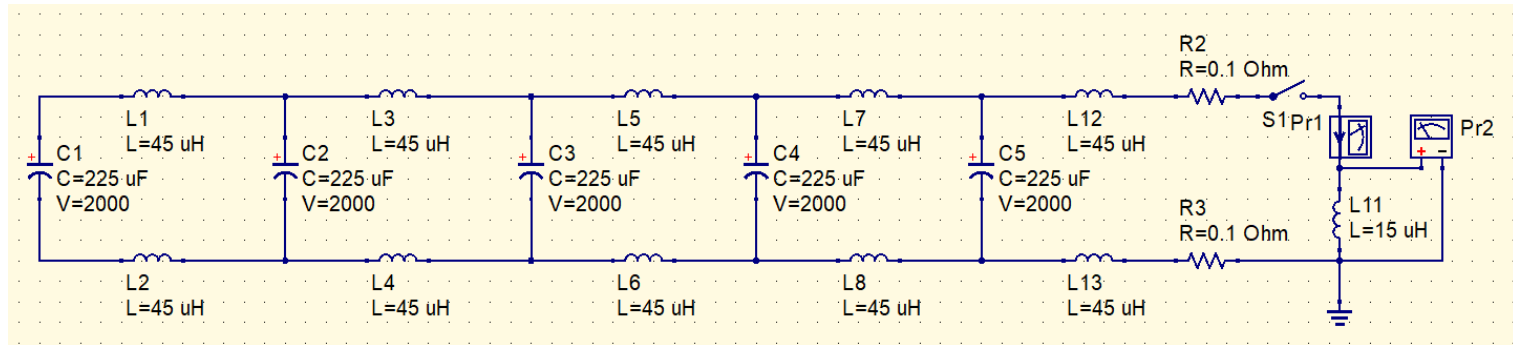

$$C \equiv \bar{C} = \frac{1}{N} \sum_{n=1}^N C_n = 225 \mu\text{F}$$

$$L_n = 2nL + L_L \approx 2nL$$

$$\omega_n = \frac{1}{\sqrt{L_n C}} \approx \frac{1}{\sqrt{2nLC}}$$

- For 5 stages:

$$\omega_5 = \frac{2\pi}{T} = \frac{\pi}{\tau} = \frac{\pi}{1\text{ms}}$$

$$L = 45 \mu\text{H}$$

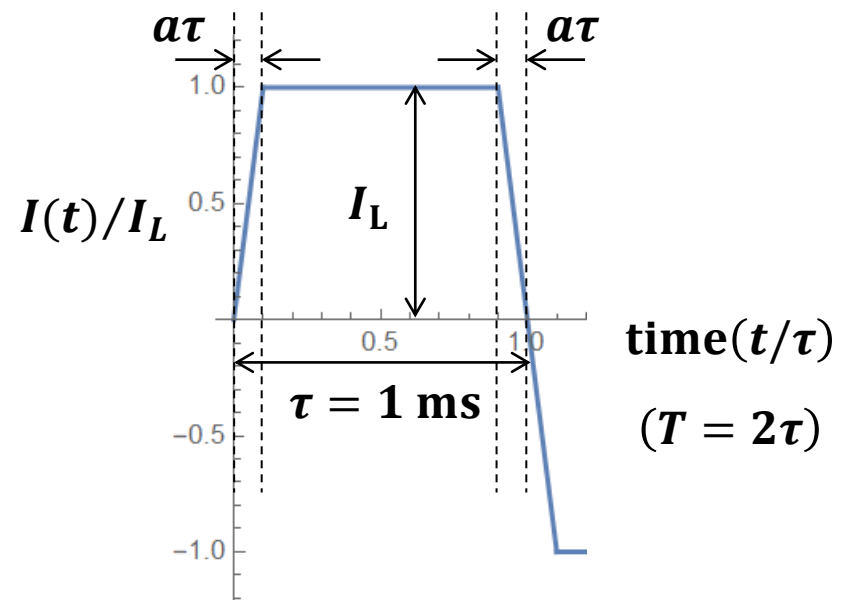

The energy coupling efficiency is lower using the simple PFN

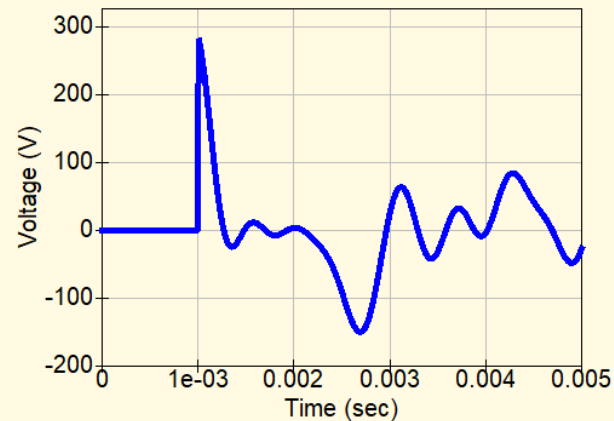
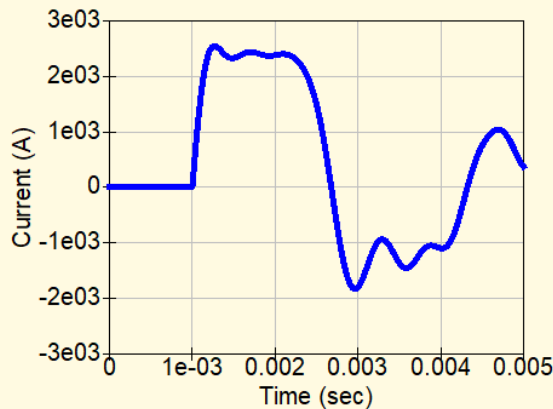
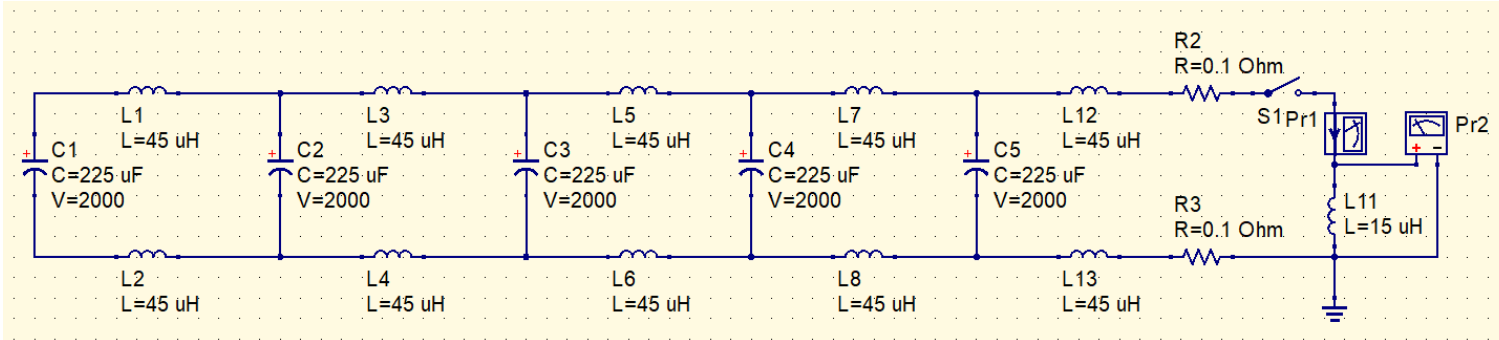

$$E = \frac{1}{2} CV^2 = 2.25 \text{kJ}$$

- Only 4.4 % of the energy is transferred to magnetic energy.

Mini-spherical tokamak

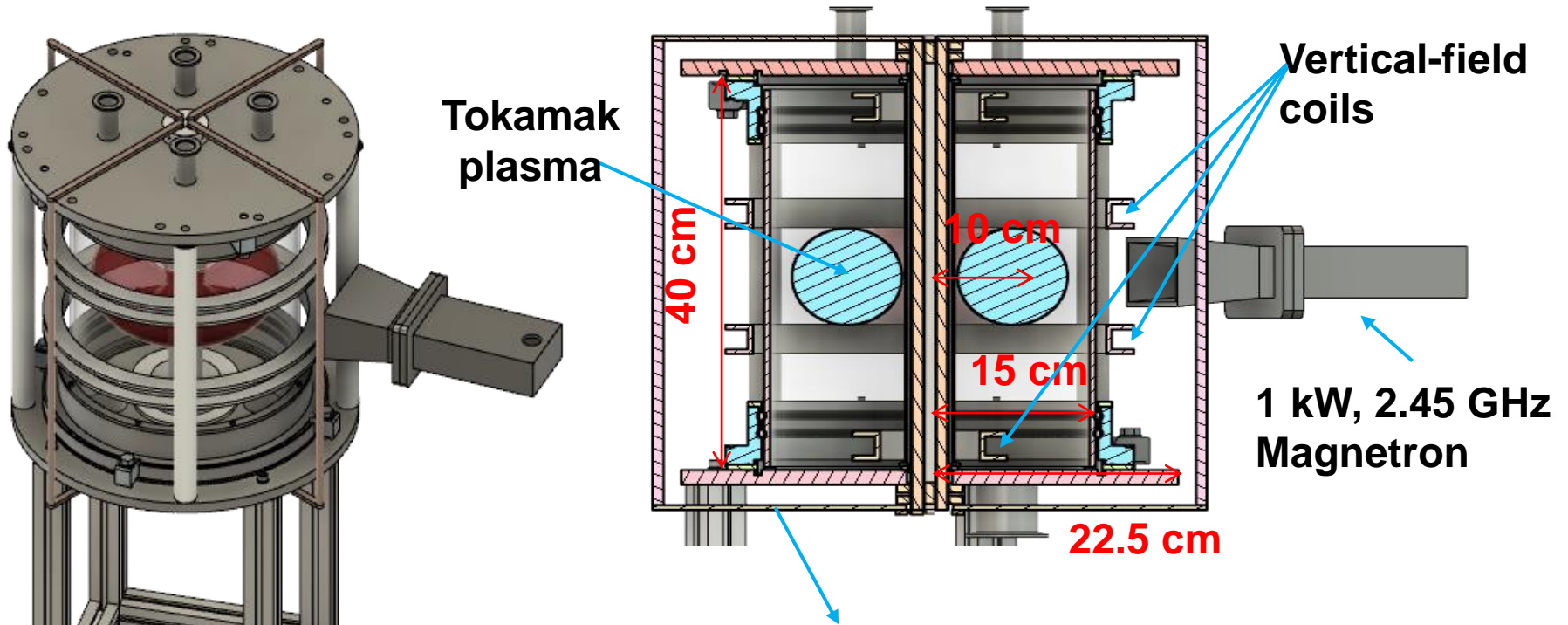

4 toroidal-field coil connected in series. 1 ms, 2.5 kA pulsed-current.

$B=876\text{ G}$ @ 4.6 cm will be used for ECR heating.

A square pulse of 2.5-kA current output with duration of 1 ms can be provided

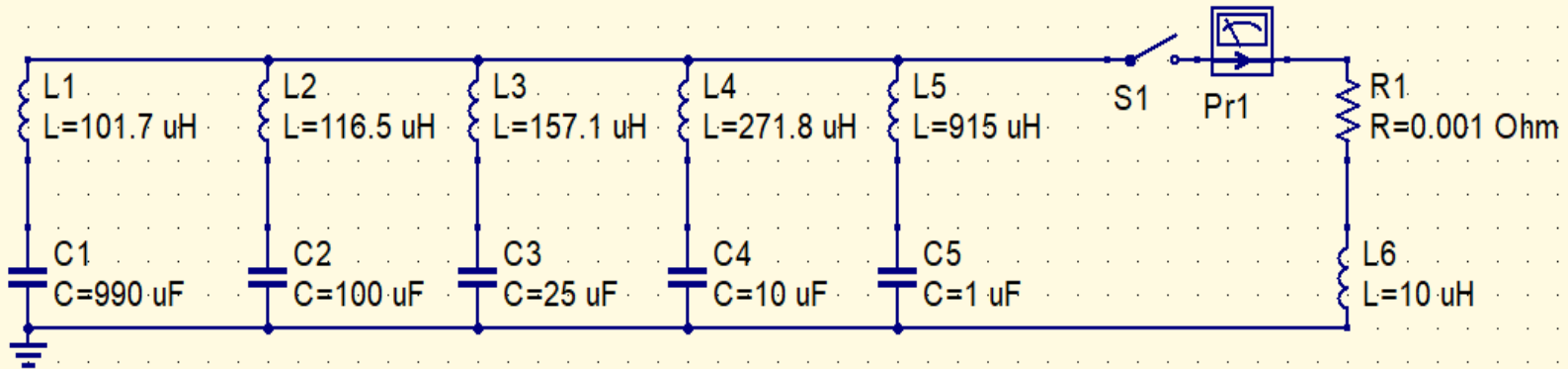

**transient
simulation**

TR1
Type=lin
Start=0
Stop=5 ms

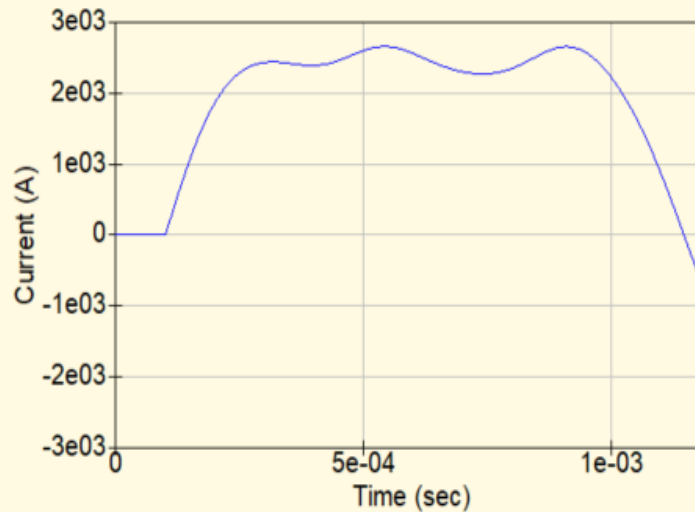

The actual components were determined by what we could get



• Design:

I (kA)	V (kV)		1	2	3	4	5
2.5	1	L(uH)	101.7	116.5	157.1	271.8	915.0
		C(uF)	996.6	96.6	25.8	7.6	1.4
2.5	1	L(uH)	102.8	114.9	157	270	-
		C(uF)	990	100	25	10	-

• Built:

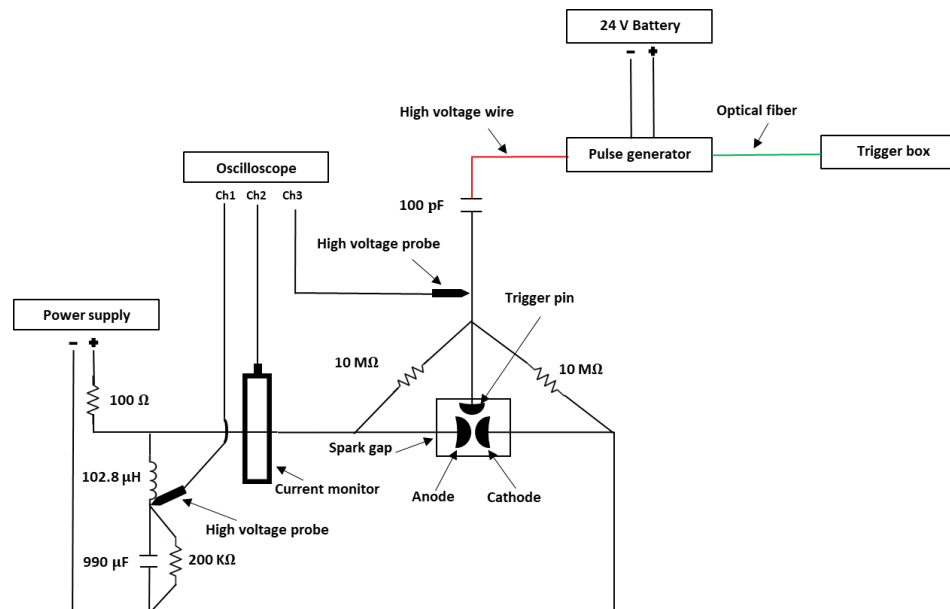

Discharge current measurements

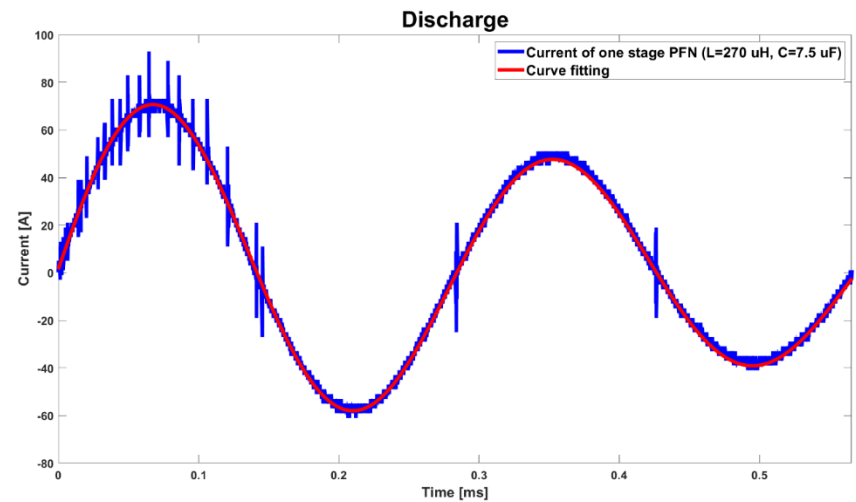
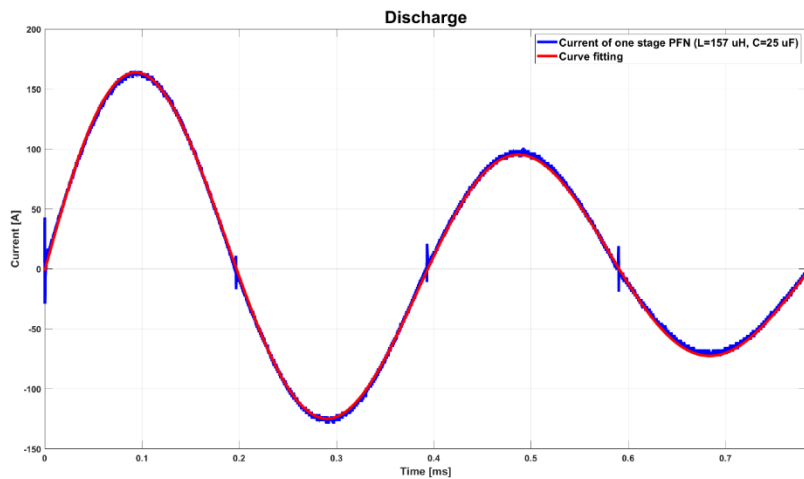
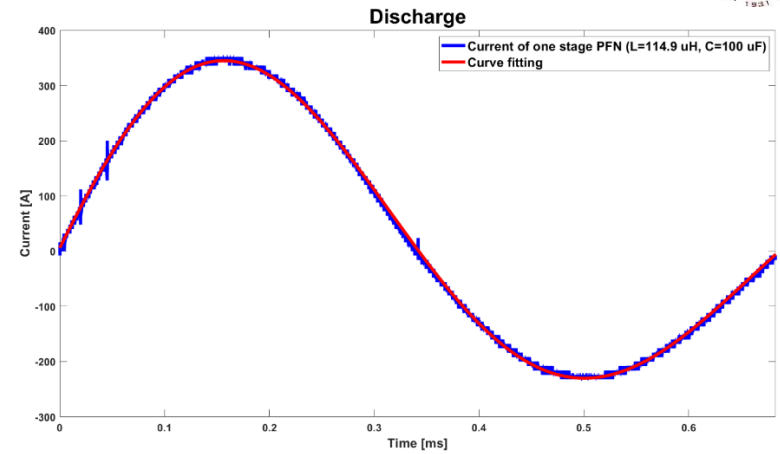
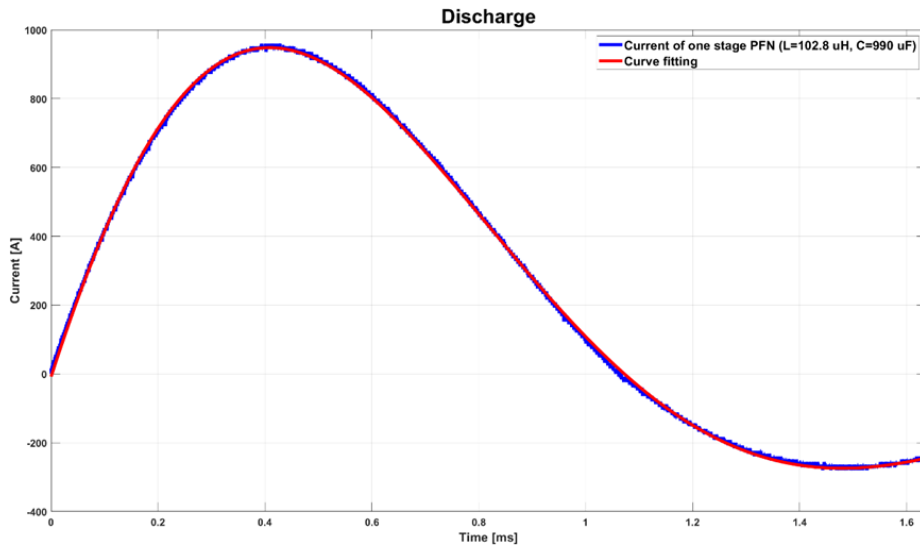

Resistant played an important role

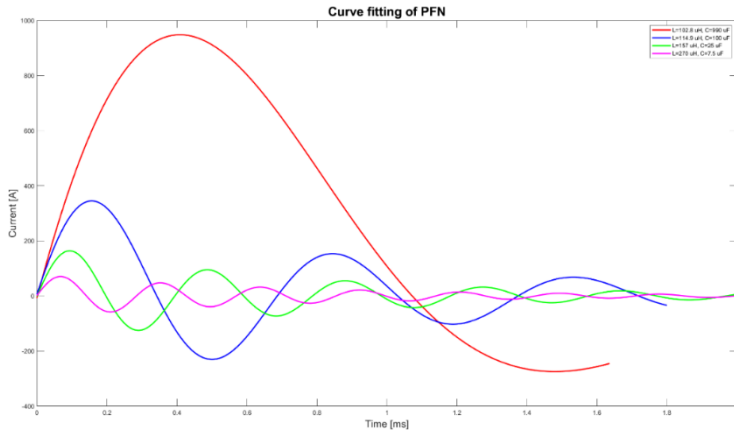

Stage	C (theory)	L (theory)	L (measure)	R (measure)
1	990 (uF)	102.8 (uH)	132±4 (uH)	0.28±0.01 (Ω)
2	100 (uF)	114.9 (uH)	123±0.4 (uH)	0.32±0.02 (Ω)
3	25 (uF)	157 (uH)	158±1 (uH)	0.43±0.01 (Ω)
4	7.5 (uF)	270 (uH)	277±7 (uH)	0.73±0.03 (Ω)

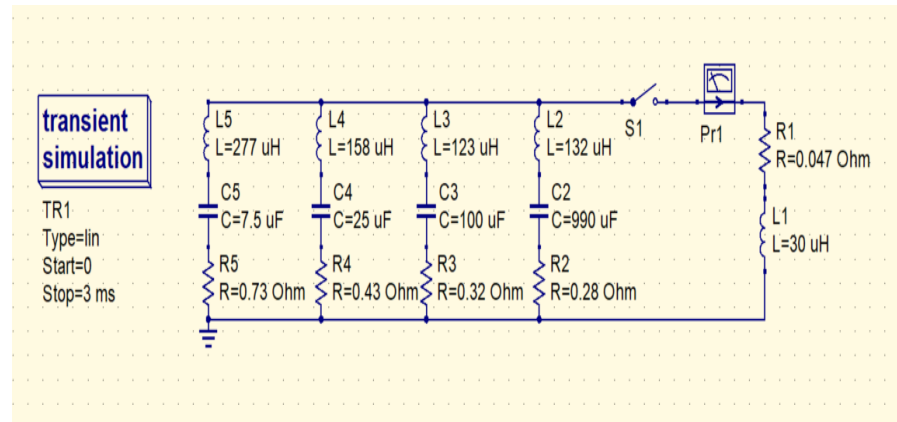
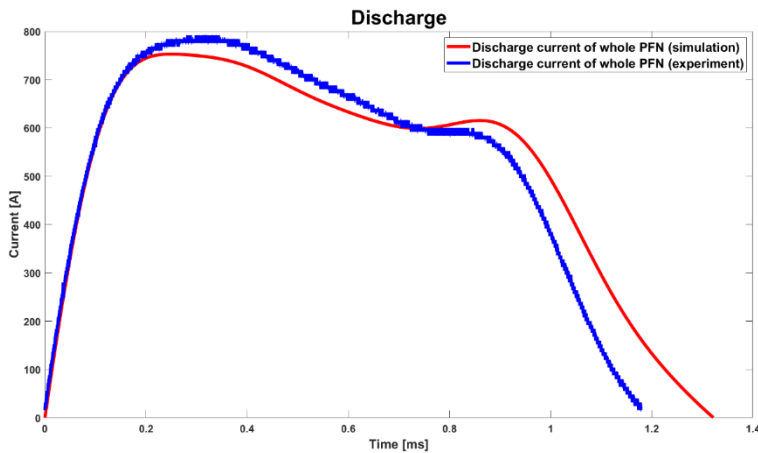

Outlines



- Switches
 - Closing switches: the switching process is associated with voltage breakdown across an initially insulant element.
 - Opening switches: the switching process is associated with a sudden growth of its impedance.
- **Pulse-forming lines**
 - Blumlein line
 - Pulse-forming network
 - **Pulse compressor**
- Pulse transmission and transformation

Capacitor load



- **Pulse compression scheme:** a charged capacitor can transfer almost all of its energy to an uncharged capacitor if connected through an inductor.
- **Output voltage can be doubled in a peaking circuit.**

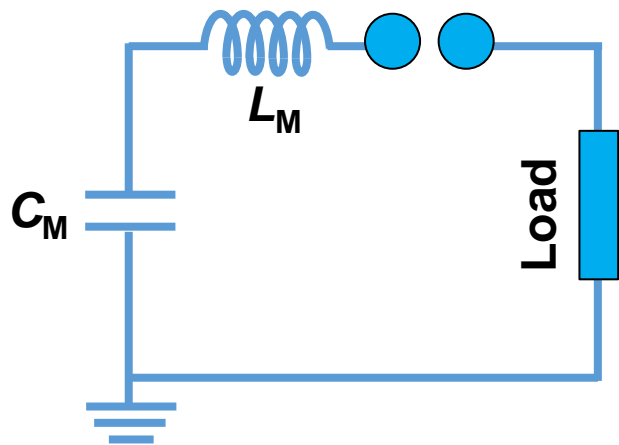

$$I_0 = \frac{V_0}{\sqrt{L_M/C_M}} \quad \omega_0 = \frac{1}{\sqrt{L_M C_M}}$$

$$L_M > L_2$$

\Rightarrow

$$I_M < I_2$$

$$\omega_M < \omega_2$$

$$T_M > T_2$$

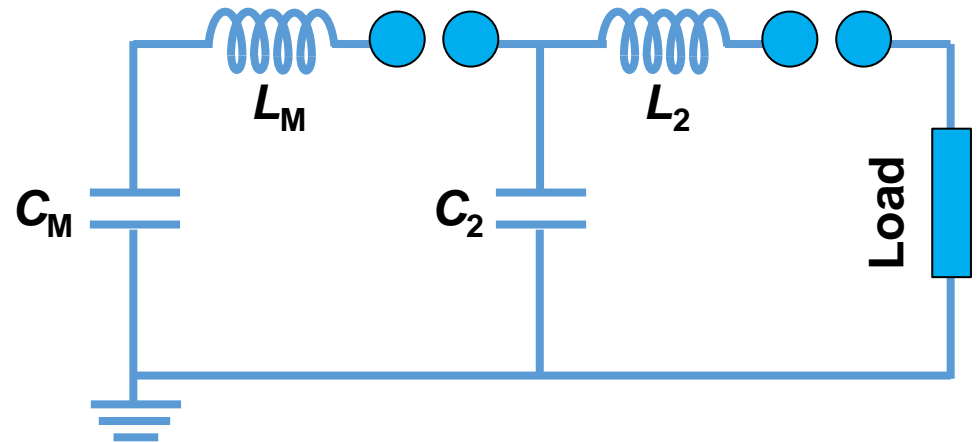

$$I_2 = \frac{V_0}{\sqrt{L_2/C_2}} \quad \omega_2 = \frac{1}{\sqrt{L_2 C_2}}$$

Capacitor load



$$V_1 - L_M \frac{dI}{dt} = V_2$$

$$V_1 = V_M - \frac{1}{C_M} \int I dt \quad V_M = NV_0$$

$$V_2 = \frac{1}{C_2} \int I dt$$

$$V_M - \frac{1}{C_M} \int I dt - L_M \frac{dI}{dt} = \frac{1}{C_2} \int I dt$$

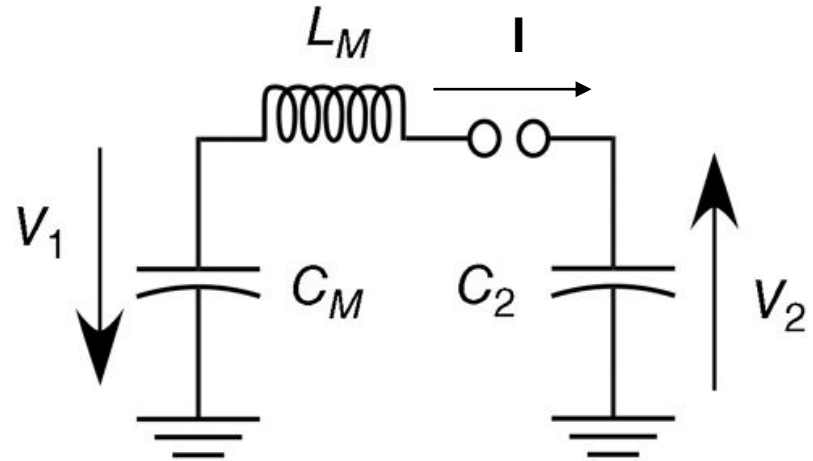

$$-\frac{1}{C_M} I - L_M \frac{d^2 I}{dt^2} = \frac{1}{C_2} I \quad L_M \frac{d^2 I}{dt^2} + \left(\frac{1}{C_M} + \frac{1}{C_2} \right) I = 0$$

$$\frac{d^2 I}{dt^2} + \frac{1}{L_M C_{\text{eff}}} I = 0 \quad \frac{1}{C_{\text{eff}}} = \frac{1}{C_M} + \frac{1}{C_2} \quad \omega = \sqrt{\frac{1}{L_M C_{\text{eff}}}}$$

$$I = \alpha \sin(\omega t) + \beta \cos(\omega t)$$

Capacitor load



$$I = \alpha \sin(\omega t) + \beta \cos(\omega t)$$

$$I(t = 0) = 0 \Rightarrow \beta = 0$$

$$I = \alpha \sin(\omega t)$$

$$\frac{dI}{dt} = \alpha \omega \cos(\omega t)$$

$$L_M \left. \frac{dI}{dt} \right|_{t=0} = L_M \alpha \omega = V_M \quad \alpha = \frac{V_M}{L_M \omega}$$

$$I(t) = \frac{V_M}{L\omega} \sin(\omega t)$$

$$V_1 = V_M - \frac{1}{C_M} \int_0^t \frac{V_M}{L\omega} \sin(\omega t) dt = V_M - \frac{V_M C_2}{C_M + C_2} [1 - \cos(\omega t)]$$

$$V_2 = \frac{1}{C_2} \int_0^t \frac{V_M}{L\omega} \sin(\omega t) dt = \frac{V_M C_M}{C_M + C_2} [1 - \cos(\omega t)] \quad \left. \frac{V_2}{V_M} \right|_{\max} = \frac{2C_M}{C_M + C_2}$$

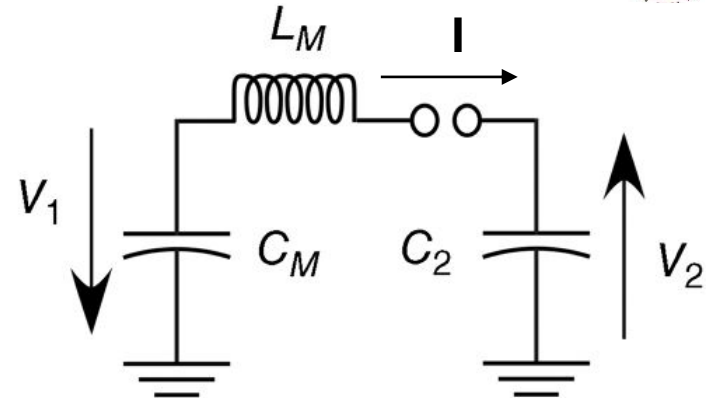

for $C_2 \sim C_M, \frac{V_2}{V_M} \sim 1$

Pulse compression scheme: $C_2 \sim C_M$

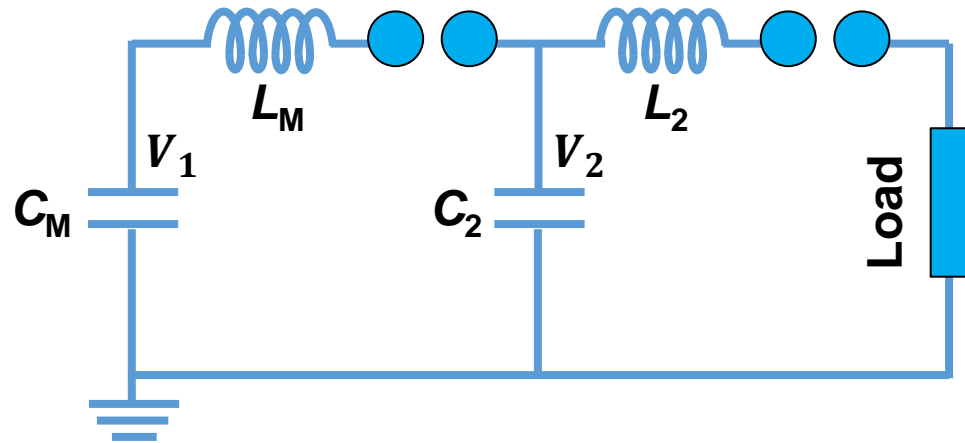
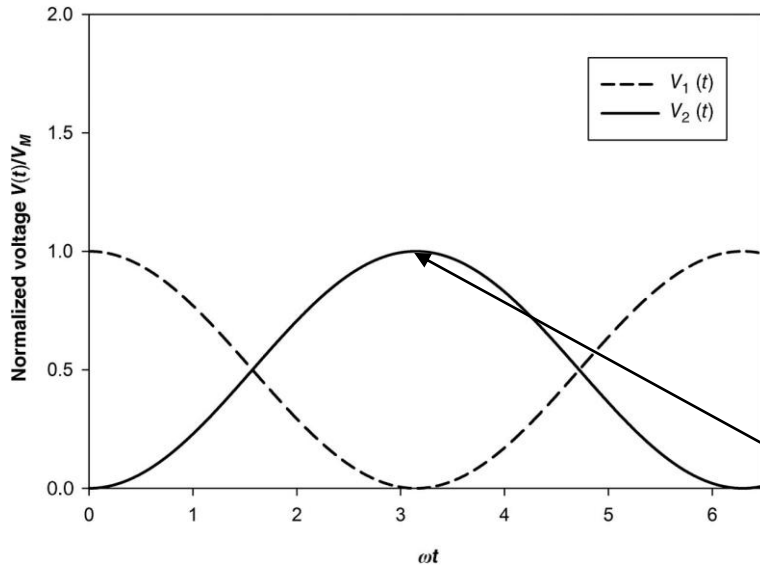

Energy is fully transferred to the 2nd cap, i.e., intermediate storage capacitor.

$$V_1 = V_M - \frac{V_M C_2}{C_M + C_2} [1 - \cos(\omega t)] \approx V_M - \frac{V_M}{2} [1 - \cos(\omega t)]$$

$$V_2 = \frac{V_M C_M}{C_M + C_2} [1 - \cos(\omega t)] \approx \frac{V_M}{2} [1 - \cos(\omega t)]$$

For $t = \frac{\pi}{\omega}$, $V_1 \approx 0$, $V_2 \approx V_M$

Water is commonly used as the dielectric material for the intermediate capacitor



$$C = \frac{2\pi\epsilon_r\epsilon_0}{\ln(b/a)} l \quad \text{For } \frac{b}{a} = \frac{1}{0.9} \approx 1.1$$

- The gap between two cylinders need to be able to handle the high voltage.

$$\text{Air: } \epsilon_r = 1 \Rightarrow \frac{C}{l} = 0.5 \times 10^{-9} \text{ F/m}$$

$$\text{Water: } \epsilon_r = 80 \Rightarrow \frac{C}{l} = 4 \times 10^{-8} \text{ F/m}$$

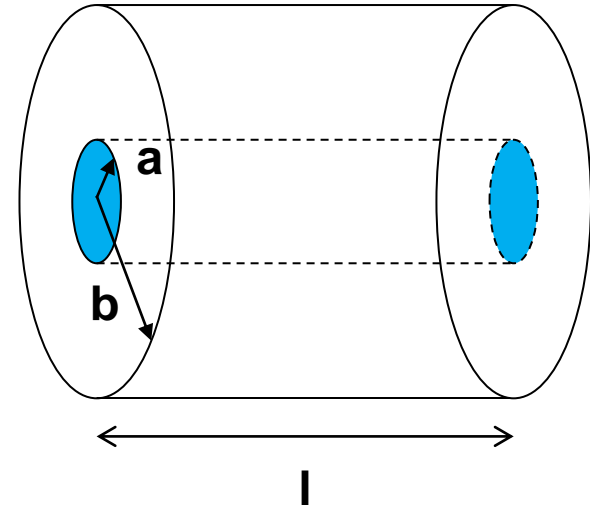

Ex: KALIF, bipolar Marx generator, charged up to ± 100 kV. $V_{M,out} = 5$ MV.

$$C_M = \frac{0.5 \mu\text{F}}{25} = 25 \text{ nF}$$

$$\text{Using air: } l = \frac{25 \times 10^{-9}}{0.5 \times 10^{-9}} = 50 \text{ m}$$

$$\text{Using water: } l = \frac{25 \times 10^{-9}}{4 \times 10^{-8}} = 0.625 \text{ m}$$

Intermediate storage capacitors can be used to compress the pulse

